

MOVANO Dropside – Recognised Conversion

European Whole Vehicle Type Approval e11*2007/46*0971*00



The Vauxhall Movano Dropside from Ingimex has been specifically designed for the transport of general freight. Optimised for strength and weight the body is light yet robust providing excellent payload capability and has been designed to meet the very latest in European design standards.

Engineered to the highest safety levels, the Ingimex dropside features a headboard with a full-height bulkhead and punched infill panel for maximum driver protection and rear visibility and a 400kg gantry capacity. The one-piece, full birch non-slip deck is top fitted for easy replacement and repair. Wire ropes support the tailboard to avoid obstructing the rear lamps and the corner posts are also removable for ease of loading. Most importantly, the board and lock assemblies have been strength tested to a load of 1.7 tonnes with the theft-resistant hinges tested to 1.3 tonnes. With sides and tailboard manufactured from seamless extruded aluminium, making them ideal for livery application, your Ingimex Movano dropside will look great too.



VX_MOV_DSIDE_21655

Unique/key selling points

- › Full-height steel bulkhead
- › Bulkhead load lashing rails
- › Retractable load deck lashing eyes
- › Under-body sheeting hooks
- › Removable rear corner posts
- › Double-skinned aluminium sides/tailboard

Typical conversion features

- › One-piece birch plywood deck
- › Extended corner posts form lateral stops
- › Wire rope supported tailboard
- › Rear mudflaps

Conversion options (at extra cost)

- › Dual coupling towing hitch
- › Storage boxes for deck and underbody
- › Sideboard extensions
- › Sideboard-mounted or underbody footsteps
- › Grab handles
- › Fall restraint rails
- › Hydraulic lifting equipment
- › 500kg tail lift

Vauxhall recognised conversions

These conversions have been tested to ensure they meet the technical standards required by General Motors UK Limited.

Movano e11*2007/46*0971*00.

Please note

Typical conversion examples shown. Conversions on other model variants are available please consult the converter. Full specification, option and colour availability details of the Movano range appear in the Movano brochure available from your Vauxhall retailer or Lo-call 0845 600 1500. Alternatively, details can be found on our website at www.vauxhall.co.uk/vans



Founded in 1972, Ingimex Limited is the UK's largest manufacturer of light commercial vehicle bodies and the only European light commercial vehicle body manufacturer to fully design, test and manufacture products in house. Quality is of the utmost importance to the company and we pride ourselves on the exceptionally high standards of safety, function and finish that we have achieved across our product range.

Converter contact details:

For conversion pricing, option and warranty details contact:
Ingimex Limited, Halesford 19, Telford, Shropshire, TF7 4QT
Email: sales@ingimex.com Website: www.ingimex.com Tel: 01952 585833

Dimensions mm (inches). Height shown unladen.

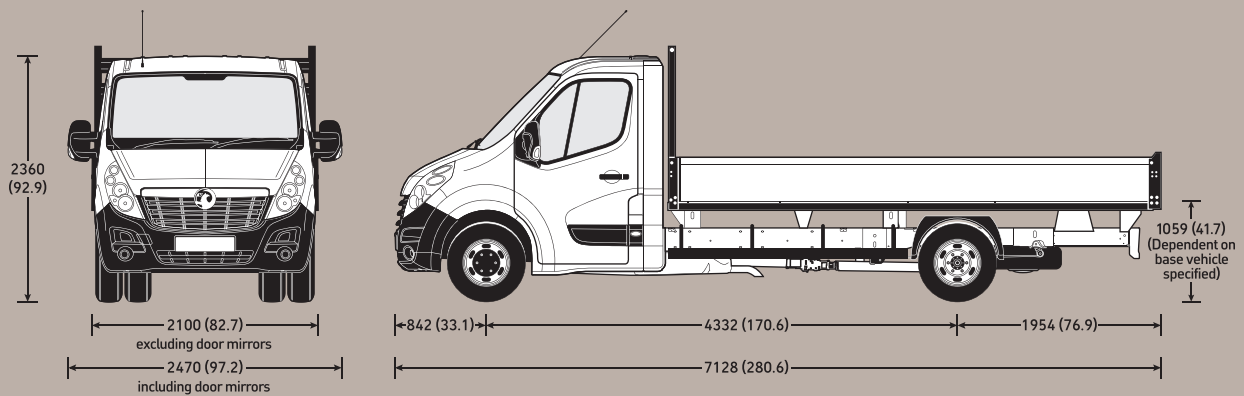

L4 H1 R3500 HD model illustrated.



VX_MOV_DSIDE_21654

Load area dimensions mm (inches)

	L2	L3	L4
Maximum length	3329 (131.1)	3979 (156.6)	4590 (180.7)
Maximum width	2026 (79.8)	2026 (79.8)	2026 (79.8)
Loading height	1010 (39.8)	1045 (41.1)	1059 (41.7)
Overall vehicle length	5995 (236.0)	6661 (262.2)	7128 (280.6)
Overall vehicle height	2360 (92.9)	2360 (92.9)	2360 (92.9)



VX_MOV_DSIDE_21657

Wire ropes support the tailboard.



VX_MOV_DSIDE_21656

Recessed, wash down lashing eyes.

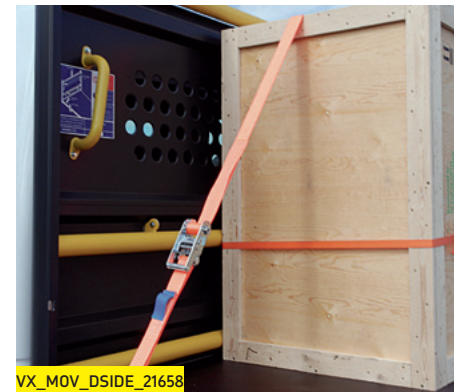

VX_MOV_DSIDE_21658

Three-level load rail lashing assembly for bulkhead.

Weights* kg for dropside models

Model	UK plated weights and kerbweights					
	Front axle	Rear axle	GVW	Kerb	Payload	GCW
L2 H1 F3500 2.3CDTI 16v	1850	2100	3500	1946	1554	6000
L3 H1 R3500 2.3CDTI 16v	1850	2300	3500	2190	1310	6000
L4 H1 R3500 HD 2.3CDTI 16v	1850	2300	3500	2335	1165	7000

*Please note: **Kerbweight** includes conversion body weight, coolant, oil, 90% full fuel tank and spare wheel. It will vary according to the vehicle specification (including options** and accessories) with a corresponding variation in payload. **Payload** figure does not allow for the weight of the driver, or any passengers, which should therefore be deducted from the figure shown. **Gross plated weight** (including axle weights) quoted on the vehicle plated must never be exceeded.

**Examples: Additional mass of Tail lift - 160-200kg (dependent of specification), Crane - 390kg. Where load capacity is critical the actual kerbweight should be obtained by weighing the vehicle on a calibrated public weighbridge.

Every effort has been made to ensure that the contents of this publication were accurate and up-to-date at the time of publication (April 2014). Vauxhall vehicles are equipped with components manufactured by various General Motors operating units and outside suppliers. The Company reserves the right to alter specifications and withdraw products from sale without notice. Any such alterations will be notified to Vauxhall retailers at the earliest opportunity; please consult your local retailer for the latest information. The specifications detailed within this brochure are not necessarily applicable to alternative models such as Special Editions. Details of any such models will be contained in specific literature or found on the Vauxhall website. Please note that Vauxhall retailers are not the agents of General Motors UK Limited and are not authorised to bind the Company by any specific or implied undertaking or representation. It is advisable to ensure that your motor insurance policy provides adequate cover for additional fitted options and accessories. Please note accessories shown are for illustrative purposes only. All rights reserved. No part of this publication may be reproduced in any form or by any means, without the prior written permission of General Motors UK Limited.

V1 ©2014 General Motors UK Limited Published April 2014 General Motors UK Limited, Luton LU1 3YT



COMMERCIAL VEHICLES
The Wheels of Business

VAUXHALL