



Grandland

Owner's Manual

Contents

Introduction.....	2
Getting to know your vehicle.....	4
Dashboard instruments and control.....	62
Infotainment.....	83
Starting & operating.....	107
Advanced driving assistance systems.....	137
In case of emergency.....	176
Maintenance and vehicle care.....	187
Technical specifications.....	202
Customer information.....	217

Introduction

Your vehicle is a designed combination of advanced technology, safety, environmental friendliness and economy.

This Owner's Manual provides you with all the necessary information to enable you to drive your vehicle safely and efficiently.

Additionally, video tutorials for some vehicle functions can be viewed in the Info Display.

Some functions are only operational when ignition is switched on, when combustion engine is running or when electric engine is ready.

Make sure your passengers are aware of the possible risk of accident and injury that may result from improper use of the vehicle.

You must always comply with the specific laws and regulations of the country that you are in. These laws may differ from the information in this Owner's Manual.

Disregarding the description given in this manual may affect your warranty. When this Owner's Manual refers to a workshop visit, we recommend your Vauxhall Authorised Repairer.

All Vauxhall Service Partners provide first-class service at reasonable prices. Experienced mechanics trained by Vauxhall work according to specific Vauxhall instructions.

The customer literature pack should always be kept ready to hand in the vehicle

Thank you for choosing a Vauxhall.

We wish you many hours of pleasurable driving.

Your Vauxhall Team

Vehicle specific data

Please refer to the sections "Maintenance and vehicle care", "Technical data", the vehicle's identification plate and national registration documents.

Using this manual

- This manual describes all options and features available for this model. **Certain descriptions, including those for display and menu functions, may not apply to your vehicle due to model variant, country specifications, special equipment or accessories.**
- The table of contents at the beginning of this manual and within each

section shows where the information is located.

- The index will enable you to search for specific information.
- This Owner's Manual depicts left-hand drive vehicles. Operation is similar for right-hand drive vehicles.
- The Owner's Manual uses the engine identifier code. The corresponding sales designation and engineering code can be found in the section "Technical data".
- Directional data, e.g. left or right, or front or back, always relate to the direction of travel.
- Displays may not support your specific language.
- Display messages and interior labelling are written in **bold** letters.

Danger, warnings and cautions

DANGER

Text marked **Danger** provides information on risk of fatal injury. Disregarding this information may endanger life.

Warning

Text marked **Warning** provides information on risk of accident or injury. Disregarding this information may lead to injury.

CAUTION

Text marked **Caution** provides information on possible damage to the vehicle. Disregarding this information may lead to vehicle damage.

Symbols



Environmental protection feature

Page references are indicated with ⇒.

⇒ means "see page".

Page references are indicated with ⇒.

⇒ means "see page".

Page references and index entries refer to the indented headings given in the section table of content.

Propulsion types

Hybrid 48 V vehicle

A hybrid 48 V vehicle is propelled by a combination of an internal combustion engine and an electric engine. The electric engine supports the internal combustion engine but can also propel the vehicle by itself. The 48 V battery is mainly charged by engine braking.

Plug-in hybrid electric vehicle (PHEV)

A PHEV is powered by an internal combustion engine and an electric engine. The internal combustion engine and electric motors operate independently or together depending on the driving conditions and driving style. The high-voltage battery is charged using a charging cable and through regenerative braking.

Battery electric vehicle (BEV)

A BEV is propelled by an electric engine only.

The high-voltage battery is charged using a charging cable and additionally by engine braking.

Getting to know your vehicle

Keys.....	5	Massage seats.....	23	Hazard warning flashers.....	45
Remote control function.....	5	Rear seats.....	24	Turn lights.....	46
Electronic key function.....	5	Folding backrests.....	24	Rear fog lights.....	46
Central locking system.....	8	Heating.....	24	Intelli-Lux HD headlights.....	46
Vehicle security system.....	10	Seat belt.....	25	Parking lights.....	49
Anti-theft locking system.....	10	Three-point seat belt.....	26	Misted light covers.....	49
Anti-theft alarm system.....	10	Airbag system.....	26	Interior lights.....	49
Immobiliser.....	12	Front airbags system.....	29	Courtesy lights.....	49
Windows.....	13	Side airbag system.....	30	Instrument panel lighting.....	49
Windscreen.....	13	Curtain airbag system.....	30	Lighting features.....	50
Windscreen stickers.....	13	Airbag deactivation.....	30	Centre console lighting.....	50
Heated windscreen.....	13	Child restraints.....	32	Entry lighting.....	50
Heated rear window.....	14	Child restraint systems.....	32	Exit lighting.....	50
Power windows.....	14	Selecting the right system.....	33	Vehicle locator lighting.....	50
Exterior mirrors.....	16	Child restraint installation locations	35	Battery discharge protection.....	50
Convex shape.....	16	Steering wheel and controls.....	40	Sunroof.....	50
Electric adjustment.....	16	Steering wheel adjustment.....	40	Interior storage.....	51
Folding mirrors.....	16	Heated steering wheel.....	40	Storage compartments.....	51
Interior mirrors.....	16	Steering wheel controls.....	40	Cup holders.....	53
Interior mirror adjustment.....	16	Horn.....	41	Lashing eyes.....	53
Automatic anti-dazzle.....	17	Start/Stop.....	41	Safety net.....	53
Head restraints.....	17	Windscreen wiper and washer.....	42	Warning triangle.....	54
Memory settings.....	18	Rear window wiper and washer.....	43	First aid kit.....	54
Driver memory settings.....	18	Exterior lighting.....	44	Loading information.....	54
Front seats.....	19	Light switch.....	44	Vehicle loading.....	55
Manual front seats adjustment.....	19	Tail lights.....	44	Load compartment.....	57
Power front seats adjustment.....	21	Automatic light control.....	44	Tailgate.....	57
Lumbar support adjustment.....	21	High beam.....	44	Power tailgate.....	57
Heating.....	22	Headlight range adjustment.....	45	General hints for operating tailgate	59
Ventilating.....	23	Headlights when driving abroad.....	45	59
		Daytime running lights.....	45	Bonnet.....	61
		Headlight flash.....	45	Opening / closing.....	61

Keys

Electronic key with keyless entry and start

Using the remote control built-in key.

⚠Warning

The electronic key can affect pacemakers.

Keep the electronic key away from your chest.



- To eject the key or put it back in place, pull and hold the button.

⚠Warning

Once the built-in key is ejected, always keep it with you, so that you can carry out the corresponding back-up procedures.

Lock cylinders

Designed to free-wheel if they are forcefully rotated without the correct key or if the correct key is not fully inserted. To reset, insert the correct key only half way and turn cylinder until its slot is vertical, remove key then re-insert it. If the cylinder still free-wheels, insert the key only half way and turn the key through 180° and repeat operation.

REMOTE CONTROL FUNCTION



- 🔒 : unlocks the vehicle
- 🔒 : locks the vehicle
-  : long press unlocks and opens the tailgate

Enables operation of the following functions via the use of the remote control buttons:

- central locking system ⇒ page 8
- anti-theft locking system ⇒ page 10
- anti-theft alarm system ⇒ page 10
- tailgate unlocking ⇒ page 8
- power windows ⇒ page 14
- mirrors folding ⇒ page 16
- Vehicle locator lighting ⇒ page 50

ELECTRONIC KEY FUNCTION

Enables a keyless operation of the following functions:

- central locking system ⇒ page 8
- power tailgate ⇒ page 57
- ignition switching on and starting the engine ⇒ page 108

The electronic key simply needs to be on the driver's person.

For reasons of security, the electronic key may be equipped with a motion sensor. If so, starting the vehicle is not possible when the electronic key has not been moved for a certain time.

When trying to start the vehicle, a corresponding message appears in the cluster. Move the electronic key and try to start the vehicle again.

Additionally, the electronic key includes the functionality of the radio remote control ⇒ page 5

Handle with care, protect from moisture and high temperatures and avoid unnecessary operation.

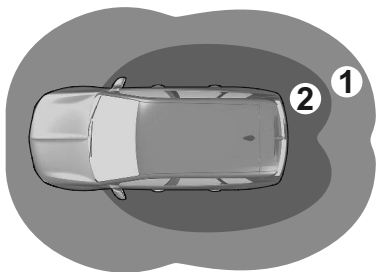



Zone 1: welcome lighting on approaching the vehicle (between 2 and 5 metres from the vehicle).

Zone 2: automatic unlocking on approaching the vehicle (between 1 and 2 metres from the vehicle).

Note

If the electronic key remains for more than 15 minutes in zone 1, automatic unlocking is deactivated.

Unlock the vehicle by pressing  or  on the remote control or touch the sensor of the driver's door handle to unlock the vehicle.

Automatic locking and unlocking is activated again.

Note

A short time after automatic unlocking, the vehicle is relocked if no door has been opened.

Unlocking

Pass a hand behind the door handle of a front door to unlock the vehicle or press the tailgate button.

Unlocking mode can be set in the Info Display. Two settings are selectable:

- Only the driver's door and fuel filler flap will be unlocked by passing a hand behind the driver's door handle.
- All doors, load compartment and fuel filler flap will be unlocked by passing a

hand behind the passenger's door handle or by pressing the tailgate button.

- Only the tailgate will be unlocked by pressing the tailgate button.

Info Display ⇒ page 63

Locking

Press marking on the front door handles.

Entire vehicle will be locked.

If the vehicle is not closed properly, the electronic key remains in the vehicle or the ignition is not off, locking will not be permitted and a warning chime sounds.

Keep the hand behind the door handle or keep the tailgate button pressed to close the windows.

Unlocking and opening the tailgate

The tailgate can be unlocked and opened hands-free by pushing the button under the tailgate moulding when the electronic key is in range.

The doors remain locked ⇒ page 57

Central locking system

Unlocks and locks doors, load compartment and fuel filler flap.

A pull on an interior door handle unlocks and opens the respective door.

Note

In the event of an accident in which airbags or belt pretensioners are deployed, the vehicle is automatically unlocked.

Note

A short time after unlocking with the remote control or electronic key, the doors are being locked automatically if no door has been opened. A precondition is that the setting is activated in the Info Display ⇒ page 63

When the driver's door-only function is activated in the vehicle personalisation settings, only the driver's door unlocks when its interior handle is pulled. When the function is deactivated all doors will be unlocked.

Central locking button

Locks or unlocks all doors, the load compartment and fuel filler flap from inside the passenger compartment.

Locks or unlocks all doors, the load compartment and fuel filler flap from inside the passenger compartment.



Press  to lock. The LED in the button illuminates.

Press  again to unlock. The LED in the button extinguishes.

Automatic locking after driving off

This system allows automatic locking as soon as the speed of the vehicle exceeds 6 mph.

If the vehicle is not closed properly, the automatic locking does not take place. This is signalled by the sound of the locks rebounding, accompanied

by illumination of  in the cluster, an audible signal and the display of an alert message.

Activation or deactivation

With the ignition on, press  and a corresponding message is displayed.

The state of the system stays in memory when switching off the ignition.

Automatic relock after unlocking

This feature automatically relocks the vehicle a short time after unlocking with the remote control or electronic key, provided vehicle has not been opened.

Battery replacement

Replacing battery in key

Replace the battery as soon as the system no longer operates properly or the range is reduced.



Batteries do not belong in household waste. They must be disposed of at an appropriate recycling collection point.



1. To unclip the cover, insert a small screwdriver between the back cover and the remote control.
2. Remove the back cover.

3. Extract the flat battery from its location.
4. Replace battery with a battery of the same type. Pay attention to the installation position.
5. Clip the cover in place.

Fault

If the central locking system cannot be operated with the radio remote control, the cause may be one of the following:

- Fault in radio remote control.
- Electronic key is out of reception range.
- The battery voltage is too low.
- The battery voltage is too high.
- Frequent, repeated operation of the radio remote control while not in range.
- Overload of the central locking system by operating at frequent intervals, the power supply is interrupted for a short time.
- Interference from higher-power radio waves from other sources.

Manual unlocking ⇨ page 8.

Replacement keys

The key number is specified on a detachable tag. The key number must be

quoted when ordering replacement keys as it is a component of the immobiliser system.

Locks ⇨ page 198

Starting the engine ⇨ page 108

Remote control function ⇨ page 5

The code number of the adapter for the locking wheel nuts is specified on a card. It must be quoted when ordering a replacement adapter.

Wheel changing ⇨ page 179

Central locking system

Operation with the key in case of a central locking system fault

In case of a fault, e.g. vehicle battery or remote control / electronic key battery is discharged, the vehicle can be locked or unlocked with the mechanical key.

Manual unlocking

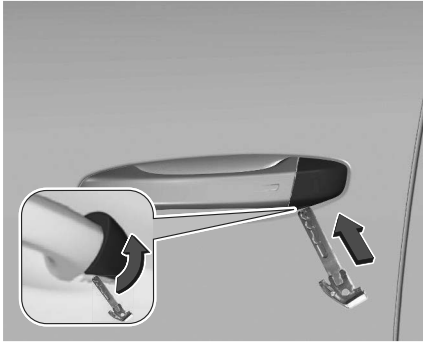

The lock cylinder in the driver's door is covered by a cap.

To remove the cap, extract the built-in key blade from the housing. Insert the key into the recess at the bottom of the cap and swivel the key upwards.

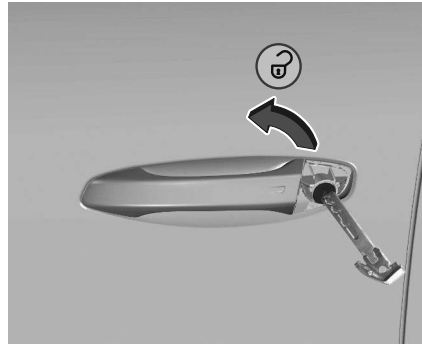

Insert the key into the lock cylinder and turn it anti-clockwise.

After locking, cover the lock cylinder with the cap: insert the cap with the lower side in the recesses, swivel and push the cap until it engages at the upper side.

By switching on the ignition, the anti-theft locking system is deactivated.

The other doors can be opened by pulling the interior handle. The load compartment and fuel filler flap will possibly not be unlocked.

Manual locking

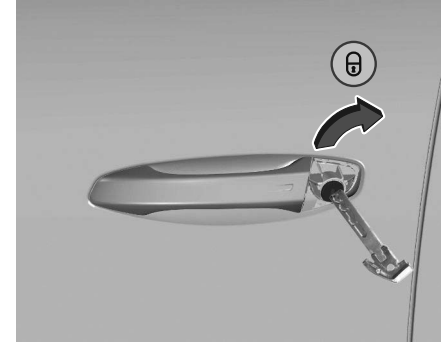

Manually lock the left front door by inserting and turning the key in the lock cylinder. With working central locking system the vehicle will be locked

Child lock

Warning

Use the child locks whenever children are occupying the rear seats.

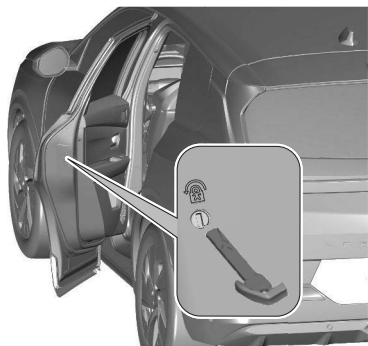

Turn the red child lock in the rear doors to the horizontal position by using a key. The door cannot be opened from the inside.

To deactivate, turn the child lock to the vertical position.

Driver's door handle

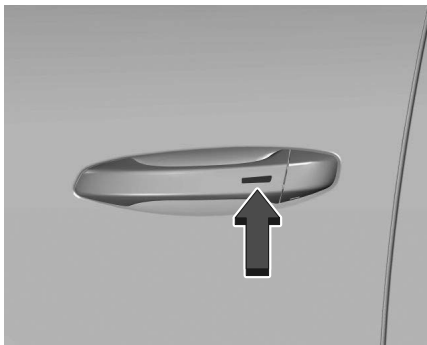

The central locking system can also be operated by touching the sensor of the driver's door handle.

Touch the sensor of the driver's door handle to unlock or to lock.

Confirmation

Operation of central locking system is confirmed by the hazard warning flashers.

Vehicle security system

ANTI-THEFT LOCKING SYSTEM

Warning

Do not use the system if there are people in the vehicle! The doors cannot be unlocked from the inside.

The system deadlocks all the doors.

All doors must be closed otherwise the system cannot be activated.

Unlocking the vehicle disables the mechanical anti-theft locking system.

This is not possible with the central locking button.

Activating

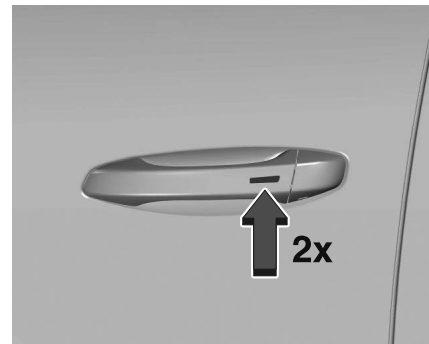

Press  on the radio remote control or touch the sensor of the driver's door handle twice within five seconds.

ANTI-THEFT ALARM SYSTEM

The anti-theft alarm system is combined with the anti-theft locking system.

It monitors:

- doors, tailgate, bonnet
- passenger compartment including adjoining load compartment
- vehicle inclination, e.g. if it is raised
- ignition

If the sunroof remains open, the passenger compartment is not monitored.

During temperature preconditioning, the passenger compartment and the vehicle inclination are not monitored.

Activation

All doors, the load compartment and the engine compartment must be closed.

The system is self-activated 45 seconds after locking the vehicle.

If a door, the tailgate or the bonnet is not properly closed, the vehicle is not locked. However, the anti-theft alarm is self-activated after 45 seconds.

Note

The automatic vehicle locking function does not activate the anti-theft alarm system.

To activate the anti-theft alarm system, lock the vehicle by using the radio remote control or by touching the sensor on the driver's door handle.

Central locking system ⇨ page 8

Note



Changes to the vehicle interior such as the use of seat covers and open windows, could impair the function of passenger compartment monitoring.

Activation without monitoring of passenger compartment and vehicle inclination

Switch off the monitoring of passenger compartment and vehicle inclination when animals are being left in the vehicle, because of high volume ultrasonic signals and because movements could trigger the alarm. Also switch off when the vehicle is on a ferry or train.

Close tailgate, bonnet, windows.



1. Press . LED in the button  illuminates for a maximum of 10 minutes.
2. Close doors.
3. Activate the anti-theft alarm system.

Indication

LED in the  button flashes if the anti-theft alarm system is activated.

Seek the assistance of a workshop in the event of faults.

Deactivation

Radio remote control: Unlocking the vehicle by pressing 

on the key deactivates the anti-theft alarm system.

The system is not deactivated by unlocking the driver's door with the built-in key or with the central locking button in the passenger compartment.

Alarm

When triggered, the alarm siren sounds and the hazard warning lights flash simultaneously. The number and duration of alarm signals are stipulated by legislation.

The anti-theft alarm system can be deactivated by pressing  or switching on the ignition.

A triggered alarm, which has not been interrupted by the driver, will be indicated by the hazard warning lights. They will flash quickly four times the next time the vehicle is unlocked with the radio remote control.

If the vehicle's battery is to be disconnected (e.g. for maintenance work), the alarm siren must be deactivated as follows: switch the ignition on then off, then disconnect the vehicle's battery within 15 seconds.

If the battery has been reconnected (e.g. after maintenance work), wait for 10 minutes to restart the engine.

Fault

If the LED in the button  illuminates permanently when switching on the ignition, seek the assistance of a workshop.

Locking the vehicle without activation of the anti-theft alarm Lock the vehicle by locking the front door with the key.

If the central locking system cannot be operated with the radio remote control, the cause may be one of the following:

- Fault in radio remote control.
- Electronic key is out of reception range.
- The battery voltage is too low.
- The battery voltage is too high.
- Frequent, repeated operation of the radio remote control while not in range.
- Overload of the central locking system by operating at frequent intervals, the power supply is interrupted for a short time.
- Interference from higher-power radio waves from other sources.

Manual unlocking ⇨ page 8.

IMMOBILISER

The system is part of the ignition switch and checks whether the vehicle is allowed to be started with the key being used.

The immobiliser is activated automatically.

Note

Radio frequency identification (RFID) tags may cause interference with the key. Do not have it placed near the key when starting the vehicle.

Note

The immobiliser does not lock the doors. Always lock the vehicle after leaving it ⇨ page 8
Switch on the anti-theft alarm system ⇨ page 10

Windows

WINDSCREEN

WINDSCREEN STICKERS

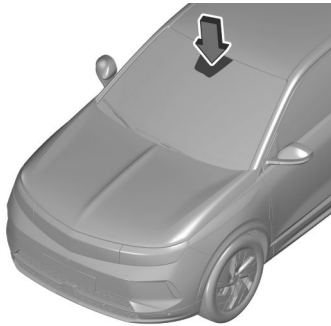

Do not attach stickers such as toll road stickers or similar on the windscreen in the area of the interior mirror. Keep the sensor free from dust, dirt and ice. Otherwise, the detection zone of the rain sensor / light sensor and the view area of the camera in the mirror housing could be restricted. ⇒ page 42

Windscreen replacement

CAUTION

If the vehicle has a front-looking camera sensor for the driver assistance systems, it is very important that any windscreen replacement is performed accurately according to Vauxhall specifications. Otherwise, these systems may not work properly and there is a risk of unexpected behaviour and / or messages from these systems.

Safety function

If the window glass encounters resistance of the window during automatic closing, it is immediately stopped and opened again.

HEATED WINDSCREEN



Press the button to activate the function.

The heating works only with freezing outside temperatures and switches off automatically after a certain time depending on the outside temperature.

HEATED REAR WINDOW



Press the button to activate the function.

The heating switches off automatically after a certain time depending on the outside temperature.

The external mirrors are also heated.

Sun visors

The sun visors can be folded down or swivelled to the side to prevent dazzling.

If the sun visors have integral mirrors, the mirror covers should be closed when driving.

A ticket holder is located on the backside of the sun visor.

POWER WINDOWS

 **Warning**

Take care when operating the power windows. Risk of injury, particularly to children.

If there are children on the rear seats, switch on the child safety system for the power windows.

Keep a close watch on the windows when closing them.

Ensure that nothing becomes trapped in them as they move.

Switch on the ignition to operate the power windows.



Operate the switch for the respective window by pushing to open or pulling to close.

Pushing or pulling gently to the first detent: window moves up or down as long as the switch is operated.

Pushing or pulling firmly to the second detent then releasing: window moves up or down automatically with safety function enabled. To stop movement, operate the switch once more in the same direction

Safety function

If the window glass encounters resistance above the middle of the window during automatic closing, it is immediately stopped and opened again.

Override safety function

In the event of closing difficulties due to frost or the like, switch on the ignition, then pull the switch to the first detent and hold. The window moves up without safety function enabled.

To stop movement, release the switch.

Child safety system for rear windows



Press the button to deactivate the rear door power windows; the LED illuminates. To activate, press again.

Closing windows from outside

The windows can be operated remotely from outside the vehicle.



Press and hold  to close the windows.

Release the button to stop window movement.

If the windows are fully closed, the hazard warning lights will flash twice.

Overload

If the windows are repeatedly operated within short intervals, the window operation is disabled for some time.

Initialising the power windows

If the windows cannot be closed automatically (e.g. after disconnecting the vehicle battery), a warning message is displayed on the cluster

Activate the window electronics as follows:

1. Close the doors.
2. Switch on the ignition.
3. Pull the switch until the window is closed and keep pulling for additional two seconds.
4. Push the switch until the window is completely open and keep pushing for additional two seconds.
5. Repeat for each window.

Fault

In some circumstances, the power windows will be opened repeatedly or may not operate correctly.

Proceed as follows:

1. Close the doors.
2. Switch on the ignition.
3. Pull the switch three times in less than 10 seconds to trigger the safety function.
4. The safety function is not active anymore. Pull the switch a fourth time until the window is completely closed.
5. Release the switch and pull the switch again for at least one second.

6. Open the window completely by pushing the switch.
7. Close the window completely by pulling the switch again.

Exterior mirrors

CONVEX SHAPE

The shape of the mirror makes objects appear smaller, which will affect the ability to estimate distances.

Side blind spot alert ⇨ page 145

ELECTRIC ADJUSTMENT



Select the relevant exterior mirror by turning the control.

Then swivel the control to adjust the selected mirror.

FOLDING MIRRORS

Folding mirrors

Manual electric folding

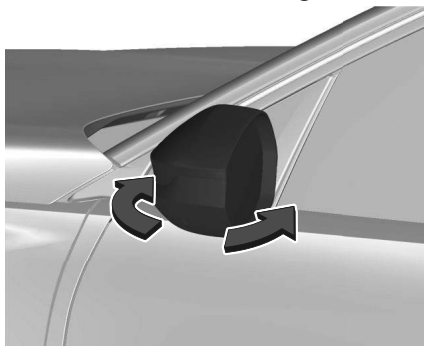

For pedestrian safety, the exterior mirrors will swing out of their normal mounting position if they are struck with sufficient force. Reposition the mirror by applying slight pressure to the mirror housing.



To fold or unfold both exterior mirrors, select the folding function by turning the control to .

If an electrically folded mirror is manually unfolded, only the other mirror will be unfolded electrically.

Automatic electric folding

When the vehicle is unlocked, the mirrors swing to their normal mounting position. When the vehicle is locked, the mirrors are folded down.

Interior mirrors

INTERIOR MIRROR ADJUSTMENT

To adjust the mirror, move the mirror housing in the desired direction.

AUTOMATIC ANTI-DAZZLE



Dazzle from following vehicles is automatically reduced when driving in the dark.

Head restraints

Head restraint position

Warning

Only drive with the head restraint set to the proper position.

The upper edge of the head restraint should be at upper head level. If this is not possible for extremely tall people,

set to highest position, and set to lowest position for small people.

Front head restraints Height adjustment

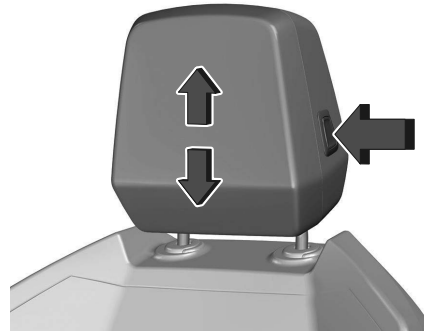

Press release button, adjust height, engage.

Longitudinal adjustment

Pull the headrest to adjust forward, press button and push to adjust backwards.

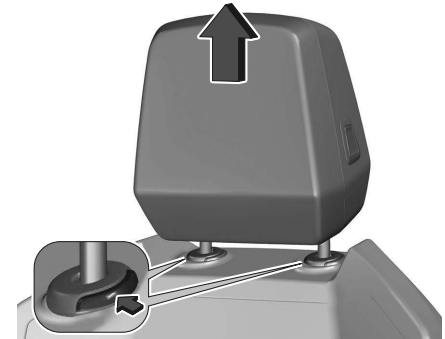

Removal

Press catch, pull the head restraint upwards and remove.

Rear head restraints

Height adjustment

Pull the head restraint upwards or press the catch to release and push the head restraint downwards.

Remove

E.g. when using a child restraint system
⇒ page 32.

Pull the head restraint upwards, press the catch to release and pull the head restraint out.

Refitting a head restraint

- Insert the head restraint rods into the guides in the corresponding seat backrest.
- Push the head restraint fully down.
- Adjust the height of the head restraint.

Memory settings

DRIVER MEMORY SETTINGS

Associated with the electrically-adjusted driver's seat, this function allows two driving positions to be memorised, to make these adjustments easier if there are frequent driver changes.

It records the electric adjustments made to the seat and door mirrors.

This also takes into account the electric settings for the extended head-up display.

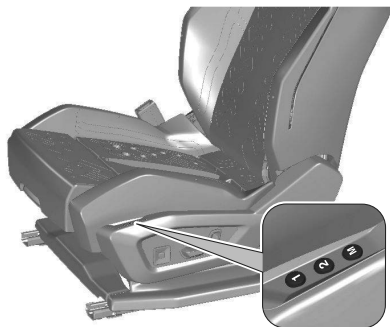

Using buttons 1/2/M

- Enter the vehicle and switch the ignition on.
- Adjust the seat, the door mirrors and the extended head-up display.
- Press button **M**, then press button **1** or **2** within 4 seconds.

An audible signal confirms the memorisation. Memorising a new position cancels the previous position.

Recalling a stored position

Warning

While the seat is moving, take care that no person or object hinders the automatic movement of the seat.

With the ignition on or engine running

- Press button **1** or **2** to recall the corresponding position.

An audible signal sounds when adjustment is complete.

You can interrupt the current movement by pressing button **M**, **1** or **2** or by using one of the seat adjustment controls.

A stored position cannot be recalled while driving. The recalling of stored positions is deactivated 45 seconds after switching off the ignition.

Comfort entry function

The Comfort entry function makes it easier to get in and out of the vehicle.

After switching off the ignition and opening the driver's door, the front seat moves backwards automatically and then stays in this position, ready for the next entry into the vehicle.

When switching on the ignition, the front seat moves forwards to the stored driving position.



It is configured in the **Settings > Vehicle** touch screen application.

Front seats

Position

Warning

Only drive with the seat correctly adjusted.

DANGER

Do not sit closer than 25 cm to the steering wheel, to permit safe airbag deployment.

Warning

Never adjust seats while driving as they could move uncontrollably.

Warning

Never store any objects under the seats.



- Sit with buttocks as far back against the backrest as possible.

Adjust the distance between the seat and the pedals so that legs are slightly angled when fully pressing the pedals. Slide the front passenger seat as far back as possible.

- Set the seat height high enough to have a clear field of vision on all sides and on instrument cluster.

There should be at least one hand of clearance between head and the roof frame. Thighs should rest lightly on the seat without pressing into it.

- Sit with shoulders as far back against the backrest as possible.

Set the backrest rake so that it is possible to easily reach the steering

wheel with arms slightly bent. Maintain contact between shoulders and the backrest when turning the steering wheel. Do not angle the backrest too far back. We recommend a maximum rake of approx. 25°.

- Adjust the seat and the steering wheel in a way that the wrist rests on top of the steering wheel while the arm is fully extended and shoulders are on the backrest.
- Adjust the steering wheel ⇨.
- Adjust the head restraint ⇨ page 17.
- Adjust the thigh support so that there is a space approx. two fingers wide between the edge of the seat and the hollow of the knee.
- Adjust the lumbar support so that it supports the natural shape of the spine.

MANUAL FRONT SEATS ADJUSTMENT

Drive only with engaged seats and backrests.

Longitudinal adjustment



Pull handle, slide seat, release handle. Try to move the seat back and forth to ensure that the seat is locked in place.

Backrest inclination



Rotate the wheel forwards or backwards to recline the seat.

Seat height

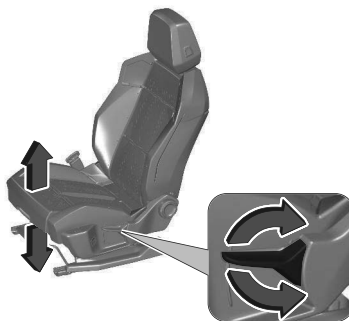

Lever pumping motion

up seat higher
down seat lower

Lumbar support

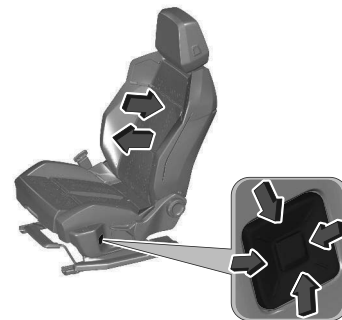

Adjust lumbar support using the four-way switch to suit personal requirements.

Press and hold the front or rear of the switch to increase or decrease the lumbar support.

Press and hold the top or bottom of the switch to raise or lower the lumbar support.

Seat angle

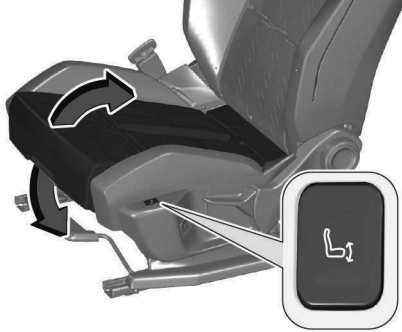

Press and hold the front or rear of the button to adjust the angle.

POWER FRONT SEATS ADJUSTMENT

Tip

Electrically adjustable seats

Switch the ignition on to enable the adjustments to be made.

Longitudinal



- Pull handle, slide seat, release handle. Try to move the seat back and forth to ensure that the seat is locked in place.

Cushion height and angle



- Tilt the rear of the control upwards or downwards to obtain the required height.
- Tilt the front of the control upwards or downwards to obtain the required angle.

Backrest angle



- Tilt the control forwards or rearwards.

LUMBAR SUPPORT ADJUSTMENT

Lumbar

The control allows independent adjustment of the depth and vertical position of the lumbar support.



- Press and hold the front or rear of the control to increase or reduce the lumbar support.
- Press and hold the top or bottom of the control to raise or lower the lumbar support area.



- Press to access seat app in infotainment screen where adjustment of seat bolsters can be made.

Thigh support

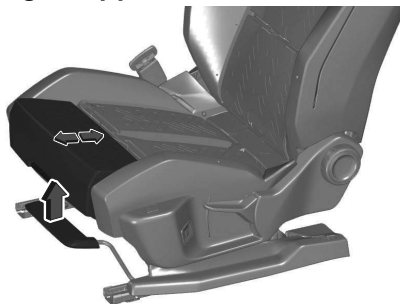

Pull the lever and slide the thigh support.

HEATING

Activation/Deactivation

Press the button in the centre of the seat adjustment control or press the climate control shortcut below the infotainment screen to access the app.

In the **Seats** touch screen application



, select the **Heating Functions** tab.

- Select the driver or passenger seat.

The corresponding page is displayed with the last memorised settings.



If the settings are suitable, press  to activate/deactivate the function in the **Seats** application.

If no action is taken, the display returns to its initial state.

The function status is not memorised when the ignition is switched off.

Changing settings

- In the **Heating Functions** page, select the relevant seat.
- Select an intensity from the three preset levels: "1" (Low), "2" (Normal) or "3" (High). The settings are memorised when the ignition is switched off.

Restriction

Do not use the function when the seat is not occupied.

Reduce the heating intensity as soon as possible.

When the seat and passenger compartment have reached a satisfactory temperature, switch the function off; reducing electrical consumption in turn decreases energy consumption.

Warning

Prolonged use of heated seats is not recommended for people with sensitive skin.

There is a risk of burns for people whose perception of heat is impaired (e.g. illness, taking medication).

To keep the heated pad intact and to prevent a short circuit:

- Do not place heavy or sharp objects on the seat.
- Do not kneel or stand on the seat.
- Do not spill liquids onto the seat.
- Never use the heating function if the seat is damp.

VENTILATING



Adjust the ventilation to the desired intensity by pressing  for the respective seat one or more times. The control indicator in the button indicates the selected intensity.

The settings are memorised when the ignition is switched off. The ventilation can also be adjusted in the seat options app in the Info Display. Touch  to activate or deactivate the ventilation. Adjust the ventilation to the desired intensity by touching the control indicator on the screen. The driver seat and the passenger seat can be adjusted independently.

MESSAGE SEATS

System with a choice of type of massage and adjustment of its intensity.

This system operates with the engine running, as well as in STOP mode of the Stop & Start.

Activation/Deactivation



In the **Seats** touch screen application, select the **Message** tab.

- Select the driver or passenger seat. The corresponding page is displayed with the last memorised settings.



If the settings are suitable, press to activate/deactivate the function in the **Seats** application.

If no action is taken, the display returns to its initial state.

The function status is not memorised when the ignition is switched off.

Changing settings

- In the **Message** page, select the seat concerned.
- Select a massage intensity from the three preset levels: "1" (Low), "2" (Normal) or "3" (High).
- Select another type of massage from those offered.

The modifications are taken into account immediately and memorised when the ignition is switched off.

Once activated, the system starts a one hour massage cycle, made up of sequences of 6 minutes of massage followed by 4 minutes at rest.

The system stops automatically at the end of the cycle.

Rear seats

Drive only with engaged seats and backrests.

⚠ Warning

Never adjust seats while driving as they could move uncontrollably.

Folding backrests ⇒ page 24.

FOLDING BACKRESTS

Folding the backrest



Pull the release lever and fold down the backrests onto the seat cushion.

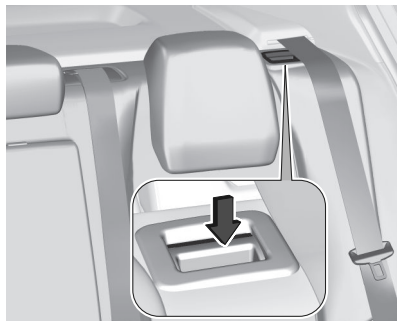

The backrests are properly engaged when the red marks near the release levers are no longer visible.

Repositioning the backrests

⚠ Warning

First check that the outer seat belts are lying vertically flat alongside the backrest latching rings.

- Put the backrest in the upright position and push it firmly to latch it home.
- Check that the release strap has correctly returned to its position.
- Ensure that the outer seat belts were not trapped during the operation.

⚠ Warning

Please note: an incorrectly latched backrest compromises the safety of passengers in the event of sudden braking or an accident.

The contents of the boot may be thrown forwards - risk of serious injury!

HEATING



The heating can be adjusted by turning the thumb wheels in the centre console.

The heating works only when the outside temperature is below 20°C.

Prolonged use of the highest intensity is not recommended for people with sensitive skin.

The settings are memorised when the ignition is switched off.

Seat belt



The seat belts are locked during heavy acceleration or deceleration of the vehicle, holding the occupants in the seat position. Therefore the risk of injury is considerably reduced.

Warning

Fasten seat belt before each trip.

In the event of an accident, people not wearing seat belts endanger their fellow occupants and themselves.

Seat belts are designed to be used by only one person at a time.

Child restraint system ⇒ page 32.

Periodically check all parts of the seat belt system for damage, soiling and proper functionality.

Have damaged components replaced. After an accident, have the seat belts and triggered seat belt pretensioners replaced by a workshop.

Note

Make sure that the seat belts are neither damaged by shoes or sharp-edged objects nor trapped. Prevent dirt from getting into the seat belt retractors.

Note

Use the belt buckle intended for the respective seat belt when fastening in order to ensure proper functionality.

Seat belt reminder

Each seat is equipped with a seat belt reminder, indicated by a control indicator for the respective seat in the overhead console.

Seat belt reminder ⇒ page 76.

Belt force limiters

Stress on the body is reduced by the gradual release of the seat belt during a collision.

Belt pretensioners

In the event of a head-on, rear-end or side-on collision of a certain severity, the front seat belts and the outer rear seat belts are tightened by seat belt pretensioners.

Warning

Incorrect handling (e.g. removal or fitting of seat belts) can trigger the belt pretensioners.

The deployment of the belt pretensioners is indicated by continuous illumination of the control indicator.

Triggered belt pretensioners must be replaced by a workshop. Belt pretensioners can only be triggered once.

Note

Do not affix or install accessories or other objects that may interfere with the operation of the belt pretensioners. Do not make any modifications to belt pretensioner components as this will invalidate the vehicle operating permit.

THREE-POINT SEAT BELT

Fasten



Withdraw the seat belt from the retractor, guide it untwisted across the body and insert the latch plate into the buckle. Make sure the seat belt lies across the shoulder and fits tightly to the body while driving.



Loose or bulky clothing prevents the seat belt from fitting snugly. Do not place objects such as handbags or mobile phones between the seat belt and your body.

⚠ Warning

The seat belt must not rest against hard or fragile objects in the pockets of your clothing.

Seat belt reminder → page 76.

Height adjustment if applicable.

Unfasten



To release seat belt, press red button on seat belt buckle and guide the seat belt back.

Using the seat belt while pregnant



⚠ Warning

The lap seat belt must be positioned as low as possible across the pelvis to prevent pressure on the abdomen.

Airbag system

The airbag system consists of a number of individual systems depending on the scope of equipment.

When triggered, the airbags inflate within milliseconds. They also deflate so quickly that it is often unnoticeable during the collision.

⚠ Warning

The airbag system deploys in an explosive manner, repairs must be performed by skilled personnel only.

⚠ Warning

Adding accessories that change the vehicle frame, bumper system, height, front end or side sheet metal, may keep the airbag system from working properly. The operation of the airbag system can also be affected by changing any parts of the front seats, seat belts, airbag sensing and diagnostic module, steering wheel, instrument panel, inner door seals including the speakers, any of the airbag modules, ceiling or pillar trim, front sensors, side impact sensors or airbag wiring.

⚠ Warning

Keep the area in which the airbag inflates clear of obstructions.

Note

The airbag systems and belt pretensioner control electronics are located in the

centre console. Do not put any magnetic objects in this area.

Do not affix any objects onto the airbag covers and do not cover them with other materials. Have damaged covers replaced by a workshop.

Each airbag is triggered only once.

Have deployed airbags replaced by a workshop. Furthermore, it may be necessary to have the steering wheel, the instrument panel, parts of the panelling, the door seals, handles and the seats replaced.

Do not make any modifications to the airbag system as this will invalidate the vehicle operating permit.

Child restraint systems on front passenger seat with airbag systems

EN: NEVER use a rearward-facing child restraint on a seat protected by an ACTIVE AIRBAG in front of it; DEATH or SERIOUS INJURY to the CHILD can occur.

DE: Nach hinten gerichtete Kindersitze NIEMALS auf einem Sitz verwenden, der durch einen davor befindlichen AKTIVEN AIRBAG geschützt ist, da dies den TOD oder SCHWERE VERLETZUNGEN DES KINDES zur Folge haben kann.

FR: NE JAMAIS utiliser un siège d'enfant orienté vers l'arrière sur un siège protégé par un COUSSIN GONFLABLE ACTIF placé devant lui, sous peine

d'infliger des BLESSURES GRAVES, voire MORTELLES à l'ENFANT.

ES: NUNCA utilice un sistema de retención infantil orientado hacia atrás en un asiento protegido por un AIRBAG FRONTAL ACTIVO. Peligro de MUERTE o LESIONES GRAVES para el NIÑO.

RU: ЗАПРЕЩАЕТСЯ устанавливать детское удерживающее устройство лицом назад на сиденье автомобиля, оборудованном фронтальной подушкой безопасности, если ПОДУШКА НЕ ОТКЛЮЧЕНА! Это может привести к СМЕРТИ или СЕРЬЕЗНЫМ ТРАВМАМ РЕБЕНКА.

NL: Gebruik NOOIT een achterwaarts gericht kinderzitje op een stoel met een ACTIEVE AIRBAG ervoor, om DODELIJK of ERNSTIG LETSEL van het KIND te voorkomen.

DA: Brug ALDRIG en bagudvendt autostol på et forsæde med AKTIV AIRBAG, BARNET kan komme i LIVSFARE eller komme ALVORLIGT TIL SKADE.

SV: Använd ALDRIG en bakåtvänd barnstol på ett säte som skyddas med en framförvarande AKTIV AIRBAG.

DÖDSFALL eller ALLVARLIGA SKADOR kan drabba BARNET.

FI: ÄLÄ KOSKAAN sijoita taaksepäin suunnattua lasten turvaistuinta istuimelle, jonka edessä on AKTIIVINEN TURVATYYNY, LAPSI VOI KUOLLA tai VAMMAUTUA VAKAVASTI.

NO: Bakovervendt barnesikringsutstyr må ALDRI brukes på et sete med AKTIV KOLLISJONSPUTE foran, da det kan føre til at BARNET utsettes for LIVSFARE og fare for ALVORLIGE SKADER.

PT: NUNCA use um sistema de retenção para crianças voltado para trás num banco protegido com um AIRBAG ACTIVO na frente do mesmo, poderá ocorrer a PERDA DE VIDA ou FERIMENTOS GRAVES na CRIANÇA.

IT: Non usare mai un sistema di sicurezza per bambini rivolto all'indietro su un sedile protetto da AIRBAG ATTIVO di fronte ad esso: pericolo di MORTE o LESIONI GRAVI per il BAMBINO!
EL: ΠΟΤΕ μη χρησιμοποιείτε παιδικό κάθισμα ασφαλείας με φορά προς τα πίσω σε κάθισμα που προστατεύεται από μετωπικό ΕΝΕΡΓΟ ΑΕΡΟΣΑΚΟ, διότι το παιδί μπορεί να υποστεί ΘΑΝΑΣΙΜΟ ή ΣΟΒΑΡΟ ΤΡΑΥΜΑΤΙΣΜΟ.

PL: NIE WOLNO montować fotelika dziecięcego zwróconego tyłem do kierunku jazdy na fotelu, przed którym

znajduje się WŁĄCZONA PODUSZKA POWIETRZNA.

Niezastosowanie się do tego zalecenia może być przyczyną ŚMIERCI lub POWAŻNYCH OBRAZEŃ u DZIECKA.

TR: Arkaya bakan bir çocuk emniyet sistemini KESİNLİKLE önünde bir AKTİF HAVA YASTIĞI ile korunmakta olan bir koltukta kullanmayınız. ÇOCUK ÖLEBİLİR veya AĞIR ŞEKİLDE YARALANABİLİR.

UK: НИКОЛИ не використовуйте систему безпеки для дітей, що встановлюється обличчям назад, на сидінні з УВІМКНЕНОЮ ПОДУШКОЮ БЕЗПЕКИ, інакше це може призвести до СМЕРТІ чи СЕРЬОЗНОГО ТРАВМУВАННЯ ДИТИНИ.

HU: SOHA ne használjon hátrafelé néző biztonsági gyerekülést előlről AKTÍV LÉGZSÁKKAL védett ülésen, mert a GYERMEK HALÁLÁT vagy KOMOLY SÉRÜLÉSÉT okozhatja.

HR: NIKADA nemojte koristiti sustav zadržavanja za djecu okrenut prema natrag na sjedalu s AKTIVNIM ZRAČNIM JASTUKOM ispred njega, to bi moglo dovesti do SMRTI ili OZBILJNJIH OZLJEDA za DIJETE.

SL: NIKOLI ne nameščajte otroškega varnostnega sedeža, obrnjenega v nasprotni smeri vožnje, na sedež z AKTIVNO ČELNO ZRAČNO BLAZINO, saj pri tem obstaja nevarnost RESNIH ali SMRTNIH POŠKODB za OTROKA.

SR: NIKADA ne koristiti bezbednosni sistem za decu u kome su deca okrenuta unazad na sedištu sa AKTIVNIM VAZDUŠNIM JASTUKOM ispred sedišta zato što DETE može da NASTRADA ili da se TEŠKO POVREDI.

MK: НИКОГАШ не користете детско седиште свртено наназад на седиште заштитено со АКТИВНО ВОЗДУШНО ПЕРНИЧЕ пред него, затоа што детето може ДА ЗАГИНЕ или да биде ТЕШКО ПОВРЕДЕНО.

BG: НИКОГА не използвайте детска седалка, гледаща назад, върху седалка, която е защитена чрез АКТИВНА ВЪЗДУШНА ВЪЗГЛАВНИЦА пред нея - може да се стигне до СМЪРТ или СЕРИОЗНО НАРАНЯВАНЕ на ДЕТЕТО.

RO: Nu utilizați NICIODATĂ un scaun pentru copil îndreptat spre partea din spate a mașinii pe un scaun protejat de un AIRBAG ACTIV în fața sa; acest lucru poate duce la DECESUL sau VĂTĂMAREA GRAVĂ a COPILULUI.

CS: NIKDY nepoužívejte dětský zádržný systém instalovaný proti směru jízdy na sedadle, které je chráněno před sedadlem AKTIVNÍM AIRBAGEM. Mohlo by dojít k VÁŽNĚMU PORANĚNÍ nebo ÚMRTÍ DÍTĚTE.

SK: NIKDY nepoužívajte detskú sedačku otočenú vzad na sedadle chránenom AKTÍVNÝM AIRBAGOM, pretože môže dôjsť k SMRTI alebo VÁŽNYM ZRANENIAM DIEŤAŤA.

LT: JOKIU BŪDU nemontuokite atgal atgretos vaiko tvirtinimo sistemas sėdynėje, prieš kurią įrengta AKTYVI ORO PAGALVĖ, nes VAIKAS GALI ŽŪTI arba RIMTAI SUSIŽALOTI.

LV: NEKĀDĀ GADĪJUMĀ neizmantojiet uz aizmuguri vērstu bērnu sēdekļi sēdvietā, kas tiek aizsargāta ar tās priekšā uzstādītu AKTĪVU DROŠĪBAS SPILVENU, jo pretējā gadījumā BĒRNS var gūt SMAGAS TRAUMAS vai IET BOJĀ.

ET: ÄRGE kasutage tahapoole suunatud lapseturvaistet istmel, mille ees on AKTIIVSE TURVAPADJAGA kaitstud iste, sest see võib põhjustada LAPSE SURMA või TÕSISE VIGASTUSE.

MT: QATT tuża trażżin għat-tfal li jħares lejn in-naħa ta' wara fuq sit protett b'AIRBAG ATTIV quddiemu; dan jista'

jikkawża l-MEWT jew GRIEHI SERJI lit-TFAL.

GA: Ná húsáid srian sábháilteachta linbh cúil RIAMH ar shuíochán a bhfuil mála aeir ag feidhmiú os a chomhair. Tá baol BÁIS nó GORTÚ DONA don PHÁISTE ag baint leis.

Additionally, for safety reasons a forward-facing child restraint system must only be used subject to the instructions and restrictions in the table⇒ page 32 .

The airbag label is located on both sides of the front passenger sun visor.

Airbag deactivation ⇒ page 30.

FRONT AIRBAGS SYSTEM

The front airbag system consists of one airbag in the steering wheel and one on the cluster on the front passenger side. These can be identified by the word **AIRBAG**.

The front airbag system is triggered in the event of a front-end impact of a certain severity. The ignition must be switched on.

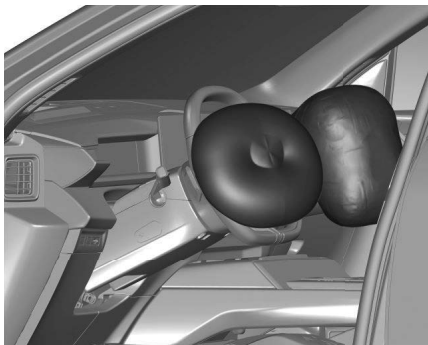

The inflated airbags cushion the impact, thereby reducing the risk of injury to the upper body and head of the front seat occupants considerably.

Warning

Optimum protection is only provided when the seat is in the proper position.

Keep the area in which the airbag inflates clear of obstructions. Fit the seat belt correctly and engage securely. Only then is the airbag able to protect.

SIDE AIRBAG SYSTEM

The side airbag system consists of an airbag in each front seat backrest.

This can be identified by the word **AIRBAG**.

The side airbag system is triggered in the event of a side impact of a certain severity. The ignition must be switched on.



The inflated airbags cushion the impact, thereby reducing the risk of injury to the upper body and pelvis in the event of a side-on collision considerably.

Note

Only use protective seat covers that have been approved for the vehicle.

Be careful not to cover the airbags.

CURTAIN AIRBAG SYSTEM

The curtain airbag system consists of an airbag in the roof frame on each side. This can be identified by the word **AIRBAG** on the roof pillars.

The curtain airbag system is triggered in the event of a side-on impact of a certain severity. The ignition must be switched on.

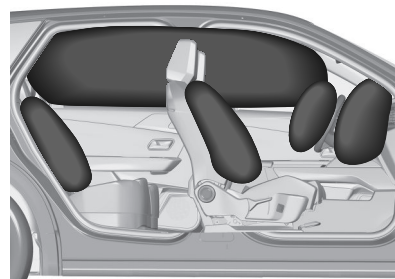

The inflated airbags cushion the impact, thereby reducing the risk of injury to the head in the event of a side-on impact considerably.

Warning

The hooks on the handles in the roof frame are only suitable for hanging up light articles of clothing, without coat hangers. Do not keep any items in these clothes.

AIRBAG DEACTIVATION

The front passenger airbag system must be deactivated for child restraint system on the passenger seat according to the instructions in the table.

The side airbag and curtain airbag systems, the belt pretensioners and all driver airbag systems will remain active. The front passenger airbag system can be deactivated via a key-operated switch on the passenger side of the cluster.

Child restraint installation locations ⇨ page 35



Use the ignition key to choose the position:



OFF front passenger airbag is deactivated and will not inflate in the event of a collision. Control indicator illuminates

continuously in the centre console



front passenger airbag is active

⚠ DANGER

Deactivate the passenger airbag only in combination with the use of a child restraint system, subject to the instructions and restrictions in the Child Restraints table.

Otherwise, there is a risk of fatal injury for a person occupying a seat with a deactivated front passenger airbag.



If the control indicator ON illuminates for approx. 60 seconds after the ignition is switched on, the front passenger airbag

system will inflate in the event of a collision.

If the control indicator OFF illuminates after the ignition is switched on, the front passenger airbag system is deactivated. It stays on while the airbag is deactivated.

If both control indicators are illuminated at the same time, there is a system failure. The status of the system is not discernible, therefore no person is allowed to occupy the front passenger seat. Contact a workshop immediately.

Consult a workshop immediately if neither of the two control indicators are illuminated.

Change status only when the vehicle is stopped with the ignition off.

Control indicator for airbag deactivation ⇨ page 30.

Child restraints

CHILD RESTRAINT SYSTEMS

DANGER

Make sure that children below sufficient size and weight are protected using a suitable child restraint system. Never place a child on the lap.

DANGER

If using a rear-facing child restraint system on the front passenger seat, the airbag system for the front passenger seat must be deactivated. This also applies to certain forward-facing child restraint systems as indicated in the Child Restraints table.

Airbag deactivation ⇒ page 30

Airbag label ⇒ page 26

We recommend a child restraint system that is tailored specifically to the vehicle. For further information, contact your workshop.

In case of any interference of the child restraint system with the vehicle seat head restraint, adjust or remove the corresponding head restraint .

When a child restraint system is being used, pay attention to the following usage and installation instructions and also those supplied with the child restraint system. The given restrictions in the table refer to a test body, which is the maximum envelope of all existing child restraint systems. Make sure that the front seats do not interfere with the used child restraint system.

Always comply with local or national regulations. In some countries, the use of child restraint systems is forbidden on certain seats.

Only drive with the driver seat correctly adjusted ⇒ page 19

DANGER

Extreme Hazard!

Do not use a rearward facing child restraint on a seat protected by an airbag in front of it.

Child restraint systems can be fastened with:

- Three-point seat belt
- ISOFIX brackets
- Top-tether anchor

Three-point seat belt

Child restraint systems can be fastened by using a three-point seat belt. After fastening the child restraint system the seat belt has to be tightened ⇒ page 35

"ISOFIX" brackets

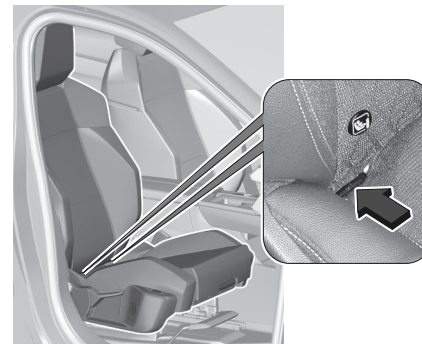

Fasten vehicle-approved ISOFIX child restraint systems to the ISOFIX brackets. Specific vehicle ISOFIX child restraint system positions are marked in the child restraints table.



ISOFIX brackets are indicated by a label on the backrest. To get access to the ISOFIX brackets, first pull the zip.

An i-Size child restraint system is an universal ISOFIX child restraint system according to UN Regulation No. 129.

All i-Size child restraint systems can be used on any vehicle seat suitable for i-Size, child restraint installation table → page 35.

When fastening ISOFIX child restraint systems on adjustable passenger seats, first incline the backrest as far as necessary backwards in order to get access to the ISOFIX brackets.

After the proper fastening of the ISOFIX child restraint system, incline the backrest forward again.

Either a top-tether strap or a support leg must be used in addition to the ISOFIX brackets.

i-Size child seats and vehicle seats with i-Size approval are marked with i-Size symbol, see illustration.



Top-tether anchors

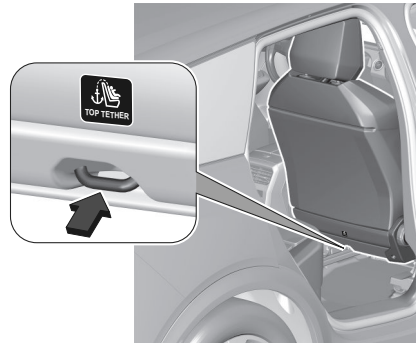

Top-tether anchors are marked with a symbol for child seat.

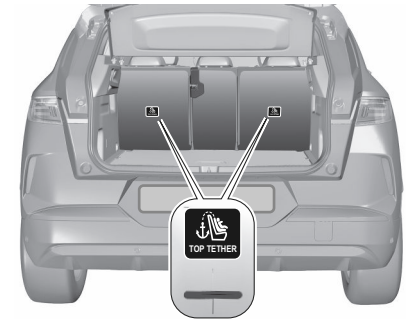

In addition to the ISOFIX brackets, fasten the top-tether strap to the top-tether anchors.

ISOFIX child restraint systems of universal category positions are marked in the table. → page 35

SELECTING THE RIGHT SYSTEM

The rear seats are the most convenient location to fasten a child restraint system.

Children should travel facing rearwards in the vehicle as long as possible. This makes sure that the child's backbone, which is still very weak, is under less strain in the event of an accident.

Do not use forward facing child restraint system at all seats when child's weight is below 13 kg or child's size is less than 76 cm and up to the age of 15 months.

Suitable are child restraint systems that comply with valid UN ECE regulations. Check local laws and regulations for mandatory use of child restraint systems.

The following child restraints are recommended for the following weight classes:

- Römer Baby-Safe 3 i-Size

Size: 40 - 83 cm

Age: from birth to 15 months

Weight: up to 13 kg

Recommended with its ISOFIX base.

Suitable for rearward facing installation only.

- Römer TriFix 2 i-Size

Size: 76 - 105 cm

Age: from 15 months to 4 years

Weight: from 9 to 22 kg

Installed with ISOFIX and Top-tether mountings.

Suitable for forward facing installation only.

- Römer Kidfix i-Size

Size: 100 - 150 cm

Age: from 3.5 to 12 years

Weight: from 15 to 36 kg

with or without ISOFIX mountings

The child is restrained by the seat belt.

Bought in Stellantis & You, Sales and Services.

We recommend using the child seat with the backrest.

If the backrest is removed for a child over 138 cm, the secure guard must also be removed.

Ensure that the child restraint system to be installed is compatible with the vehicle type.

Child seat at the front: Adjust the front passenger seat to the highest and fully back longitudinal position with the backrest straightened.

Child seat at the rear: Move the vehicle's front seat forward and straighten the backrest so that the legs of the child in the forward facing or the rearward facing child seat do not touch the vehicle's front seat.

In case of any interference of the child restraint system with the vehicle seat head rest, adjust or remove the corresponding vehicle seat head rest.

Please follow the child restraint manufacturer's instructions to install the corresponding child restraints in the vehicle.

For semi-universal or vehicle specific child restraint system (ISOFIX or belted child restraint system), see the vehicle list provided in the user manual of the child restraint system.

Ensure that the mounting location of the child restraint system within the vehicle is correct, see following table.

Allow children to enter and exit the vehicle only on the side facing away from the traffic.

When the child restraint system is not in use, secure the seat with a seat belt or remove it from the vehicle.

Note

Do not affix anything on the child restraint systems and do not cover them with any other materials. A child restraint system that has been subjected to stress in an accident must be replaced.

CHILD RESTRAINT INSTALLATION LOCATIONS

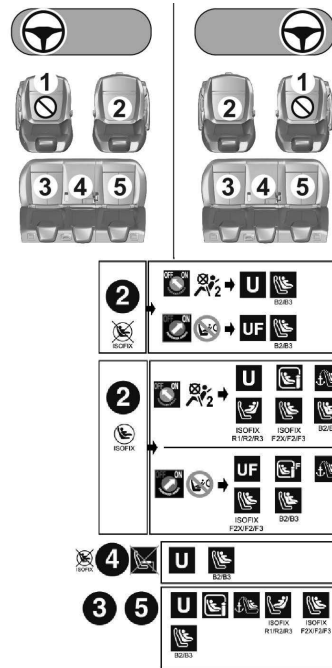

Key



Seat position where the installation of a child seat is forbidden.



Front passenger airbag **deactivated**.





Front passenger airbag **activated**.



Seat position suitable for the installation of a child seat secured using the seat belt and universally approved **"rearward facing"** and/or **"forward facing"** (U) for groups **0, 0+, 1, 2** or **3** or dedicated to children between 40 to 150 cm in size.



Seat position suitable for the installation of a child seat secured using the seat belt and **universally approved "forward facing"** (UF) for groups **1, 2** and **3**, or dedicated to children between 76 and 150 cm in size only.



Seat position authorised for the installation of an **i-Size** child seat.



Seat position authorised for the installation of a **"forward facing" i-Size** child seat



Seat position not suitable for the installation of a child seat with support leg.



Presence of a **Top Tether** anchorage point at the rear of the backrest, authorising the installation of an **universal ISOFIX child seat**.



Presence of a TOP TETHER anchorage point at the rear of the backrest, authorising the installation of a **"forward facing" universal ISOFIX child seat**.



"Rearward facing" **ISOFIX** child seat:

- **R1: ISOFIX** child seat for a **baby**
- **R2: ISOFIX reduced size** child seat.
- **R3: ISOFIX** large size child seat



"Forward facing" **ISOFIX** child seat:

- **F2X: ISOFIX** child seat **for toddlers**.

- **F2: ISOFIX reduced height** child seat.
- **F3: ISOFIX full height** child seat.



Booster child seat, using seat belt or **ISOFIX** mountings:

- **B2: reduced width booster seat.**
- **B3: full width booster seat.**



Seat position where the installation of an **ISOFIX** child seat is forbidden.

For seat adjustments, refer to the summary table "**Installing universal, ISOFIX and i-Size child seats**".



Seat position authorised for the installation of an **ISOFIX** child seat.



ISOFIX "carry-cot" type child seat :

- **L1** : left-hand facing.
- **L2** : right-hand facing.

In compliance with European regulations, this table indicates the options for installing child seats secured using the seat belt and universally approved (a) as well as the largest ISOFIX and i-Size child seats on seat positions equipped with ISOFIX mountings in the vehicle.

Yes : Suitable for fitment of the designated category of the child restraint system.

No : Not suitable for fitment of the designated category of the child restraint system.

Summary table for installation of universal, ISOFIX and i-Size child seats.

	Seat numbers				
	Front seats ^(b)		Rear seats ^(b) row 2		
	1	2	3	4	5
Front passenger airbag		Deactivated "OFF" ^(c)	Activated "ON" ^(d)		
Position compatible with a universal ^(a) child seat Rearward Facing ^(e)	no	yes ^{(g)(h)}	no	yes	yes ⁽ⁱ⁾
Position compatible with a universal ^(a) child seat Forward Facing ^(f)	no	yes ^{(g)(h)}		yes	yes ⁽ⁱ⁾
Position compatible with an i-Size child seat Rearward Facing	no	no ^(j) / yes ^(k)	no	yes	no
Position compatible with an i-Size child seat Forward Facing	no	no ^(j) / yes ^(k)		yes	no
Position compatible with a TOP TETHER hook	no	no ^(j) / yes ^(k)		yes	no
" Carry-cot " type of child seat (L1 / L2)	no	no		no	no
" Rearward facing " ISOFIX child seat (R1/R2/R3)	no	no ^(j) / R3 ^{(h)(k)}	no	R3	no
" Forward facing " ISOFIX child seat (F1/F2X/F3)	no	no ^(j) / F3 ^{(h)(k)}		F3	no
" Booster " child seat (B2 / B3) ^(m)	no	B3 ^{(h)(j)(k)}		B3	B3 ^{(i) (j)}

(a) Universal child seat: child seat that can be installed in all vehicles using the seat belt.

(b) Depending on version, refer to the legislation in force in your country before carrying a child at this seat position.

- (c) To install a **"rearward facing"** child seat at this seat position, the front passenger airbag **MUST** be deactivated **"OFF"**.
- (d) Only a **"forward facing"** child seat is authorised at this seat position with the front passenger airbag activated **"ON"**.
- (e) For a **"rearward facing"** and/or **"forward facing" universal child seat (U)** for groups **0, 0+, 1, 2** or **3** or dedicated to children between 40 and 150 cm in size.
- (f) For a **"forward facing" universal child seat (UF)** in groups **1, 2** or **3**, or dedicated to children between 76 cm and 150 cm in height only.
- (g) For a seat with height adjustment, adjust it to the highest position.
- (h) Adjust the front passenger seat to the fully rearward longitudinal position.
- (i) A child seat with a support leg must never be installed on the centre rear passenger seat.
- (j) Seat not fitted with ISOFIX compliant mountings.
- (k) Seat fitted with ISOFIX compliant mountings.
- (l) If a child restraint system is installed on these seats, adjust the head restraint of the seat to the maximum height position or remove it if necessary.
- (m) It is not possible to install 3 booster child seats on the rear seats at the same time.

Rules:

- A position that is i-Size compatible is also compatible for R1, R2 and F2X, F2, B2.
- A position that is R3 compatible is also compatible for R1 and R2.
- A position that is R2 compatible is also compatible for R1.
- A position that is F3 compatible is also compatible for F2X and F2.
- A position that is B3 compatible is also compatible for B2.

Steering wheel and controls

STEERING WHEEL ADJUSTMENT



- When stationary, pull the control to release the steering wheel.
- Adjust the height and reach to suit your driving position.
- Push the control to lock the steering wheel.

Warning

For safety reasons, these adjustments must only be carried out with the vehicle stationary.

Tip:

Driving information and infotainment are available on a 10-inch and a 16-inch screen.

The instrument panel information is visible above the steering wheel, for greater safety and driving comfort.

Adjust the steering wheel height so that it does not obstruct the instrument panel.

HEATED STEERING WHEEL

In cold weather, this function heats the circular part of the steering wheel.

It can be activated when the outside temperature is below 20°C.



In the Climate touch screen application, select the Seats and Steering Wheel tab.



Press  to activate/deactivate the function.

The function is memorised each time the engine is switched off.

STEERING WHEEL CONTROLS



Some driver assistance systems, the Infotainment system and a connected mobile phone can be operated via the controls on the steering wheel.

Advanced driving assistance systems ⇨ page 137

Infotainment system ⇨ page 83

HORN



Start/Stop

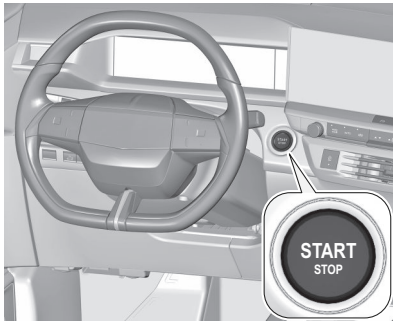

Engine start

Operate the brake pedal and press Start/Stop.

Ignition on power mode without starting the engine

Press Start/Stop without operating the brake pedal. Control indicators illuminate and most electrical functions are operable.

Engine and ignition off

Press **Start/Stop** briefly in each mode or when engine is running and vehicle is stationary. Some functions remain active until driver's door is opened.

Leaving the vehicle

⚠ Warning

Only leave the vehicle with propulsion system off, parking brake applied and depending on transmission first gear engaged or **P** selected.

Parking

⚠ Warning

Do not park the vehicle on an easily ignitable surface. The high temperature of the exhaust system could ignite the surface.

- Apply the parking brake.
- If the vehicle is on a level surface or uphill slope, engage first gear or press **P**. On an uphill slope, turn the front wheels away from the kerb.
- If the vehicle is on a downhill slope, engage reverse gear or press **P**. Turn the front wheels towards the kerb.
- Close the windows.
- Switch off the engine.
- Switch off ignition on vehicles with power button. Depending on version, turn the steering wheel until the steering wheel lock is felt to engage.

Steering wheel lock

The steering wheel lock activates automatically when:

- the vehicle is stationary.
- the ignition has been switched off.

To release steering wheel lock, open and close driver's door and switch the ignition on power mode or start the engine directly.

Warning

If the vehicle battery is discharged, the vehicle must not be towed or tow-started as the steering wheel lock cannot be disengaged.

Windscreen wiper and washer

Note

With the wiper lever in position AUTO or INT, 1 or 2 and the ignition switched on after more than one minute: When the outside temperature is below +3°C, the windscreen wiper activates only at a speed above 10 km/h. When the outside temperature is above +3°C, the windscreen wiper activates immediately.

Note

In position 1 or 2, the wiping frequency is automatically reduced at a speed below 5 km/h and returns to the original frequency at a speed above 10 km/h.

Windscreen wiper with adjustable wiper frequency



- 2 : fast
- 1 : slow
- INT : interval wiping
- 0 : off
- x1 : single wipe

Do not use if the windscreen is frozen.

Switch off in car washes.

To activate interval wiping mode the next time the ignition is switched on, press the lever downwards to position OFF and back to INT.

Wiper frequency

Wiper lever in position INT, the wiping frequency is dependent on the speed of the vehicle.

Windscreen wiper with rain sensor



- 2 : fast
- 1 : slow
- INT : interval wiping
- 0 : off
- AUTO : automatic wiping with rain sensor

In **AUTO** position, the rain sensor detects the amount of water on the windscreen and automatically regulates

the frequency of the windscreen wiper. If the ignition is switched off, automatic wiping mode is deactivated. To activate automatic wiping mode the next time the ignition is switched on, press the lever downwards to position **OFF** and back to **AUTO**.

Do not use if the windscreen is frozen.

Switch off in car washes.

Adjustable sensitivity of the rain sensor



Wiper lever in position **AUTO**.

In **AUTO** position, the rain sensor detects the amount of water on the windscreen and automatically regulates the frequency of the windscreen wiper.

The sensitivity can be adjusted with the switch on the stalk. Push upwards to

increase and downwards to decrease sensitivity.

Make sure the sensor is not blocked ⇒ page 13 .

Control indicator ⇒ page 109.

Windscreen washer



Pull the lever. Washer fluid is sprayed onto the windscreen and the wiper wipes a few times.

Washer fluid ⇒ page 195.

Rear window wiper and washer

Rear window wiper



0 : off



: intermittent wiping



: screen wash

Do not use if the rear window is frozen or when a bicycle carrier is used. Switch off in car washes. The rear window wiper comes on automatically when the windscreen wiper is switched on and reverse gear is engaged.

Rear window washer

Select 

Washer fluid is sprayed onto the rear window and rear view camera and the

wiper wipes as long as  is selected.

Washer fluid ⇒ page 195

Exterior lighting

Main lighting

LIGHT SWITCH

Warning

Do not look directly into the LED headlights. Risk of eye damage.

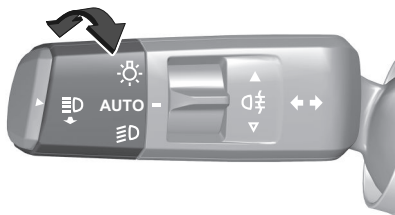

Turn the light switch:



sidelights

AUTO

automatic light control switches automatically between daytime running lights and low beam



low beam / high beam

Control indicator ⇒ page 74.

TAIL LIGHTS

Tail lights are illuminated together with low beam and daytime running lights.

AUTOMATIC LIGHT CONTROL

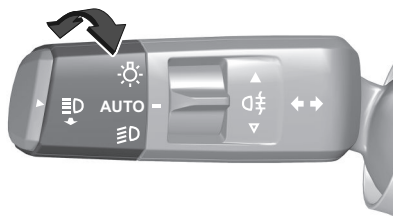

When the automatic light control function is switched on, the system switches between daytime running lights and low beam automatically depending on the external lighting conditions and information given by the wiper system.

Automatic headlight activation

Turn the switch in position: **AUTO**

During poor lighting conditions the low beam is switched on.

Additionally, headlights are switched on if the windscreen wipers have been activated for several wipes.

HIGH BEAM

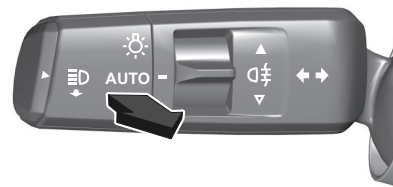

Pull the lever beyond the resistance point to switch between low beam and high beam.

HEADLIGHT RANGE ADJUSTMENT

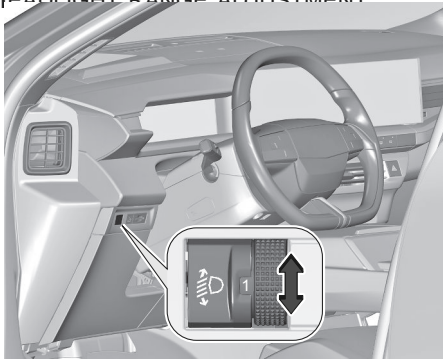

To adapt headlight range to the vehicle load to prevent dazzling: turn thumb wheel to required position.

Table 1: MHEV/PHEV

0	driver's seat occupied
1	all seats occupied
2	all seats occupied and load compartment laden
3	driver's seat occupied and load compartment laden

Table 2: BEV

0	driver's seat occupied
1	all seats occupied
1	all seats occupied and load compartment laden
2	driver's seat occupied and load compartment laden

HEADLIGHTS WHEN DRIVING ABROAD

When driving in countries where traffic drives on the opposite side of the road, the headlights do not have to be adjusted.

DAYTIME RUNNING LIGHTS

Daytime running lights increase visibility of the vehicle during daylight ⇨ page 44.

HEADLIGHT FLASH

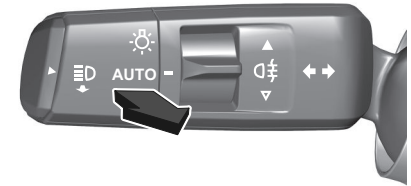

Pull to the point of resistance to activate the high beam flash.

HAZARD WARNING FLASHERS



Press the button to operate.

When braking in an emergency, the hazard warning flashers are switched on automatically, depending on the force of deceleration. When the vehicle starts moving again, the hazard warning flashers must be deactivated manually.

TURN LIGHTS

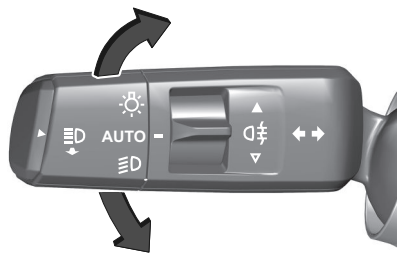

up : right turn light

down : left turn light

A resistance point can be felt when moving the indicator lever.

Constant flashing is activated when the indicator lever is being moved beyond the resistance point. It is deactivated when the steering wheel is moved in the opposite direction or indicator lever is manually moved back to its neutral

position. After 20 seconds the volume of the audible signal will increase if the speed is above 50 mph.

Activate temporary flashing by holding the indicator lever just before the resistance point. Turn lights will flash until indicator lever is being released.

To activate three flashes, tap the indicator lever briefly without passing the resistance point.

REAR FOG LIGHTS

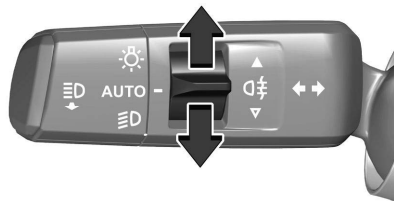

Push the switch up to switch on the rear fog light.

Push the switch down to switch off the rear fog light.

INTELLI-LUX HD HEADLIGHTS

The Intelli-Lux HD headlight system contains a variety of particular LEDs in each headlight which enables the control of the adaptive forward lighting functions.

Light distribution and intensity of light are variably triggered depending on the lighting conditions, road type and driving situation. The vehicle adapts the headlights automatically to the situation to enable optimal light performance for the driver.

The adaptive forward lighting and the Intelli-Lux HD headlights functions can be deactivated or activated in the Info Display and by switching off or on the automatic light control.

Info Display ⇔ page 68

The following functions are available if the adaptive forward lighting is activated on the Info Display and the light switch is in **AUTO**.

Pedestrian light

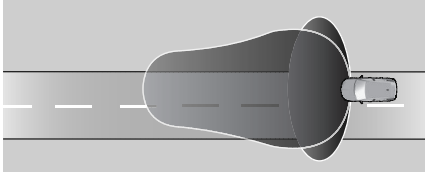

Activated automatically when the vehicle starts moving and up to a speed of 15 mph. This light is designed to enhance visibility of pedestrians on the sides of the vehicle.

Town light

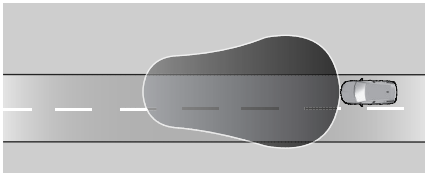

Activated automatically at a speed below 18 mph and deactivated after a few seconds with a speed above 30 mph. The light is wide to better recognise hazards along the road, e.g. pedestrians, crossings.

Country light

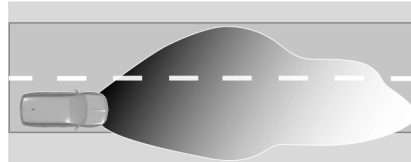

Activated automatically after a small delay when above 30 mph when driving in rural areas. The illumination of the current lane and the side of the road is adapted. Oncoming and preceding vehicles are not dazzled.

Adverse weather light

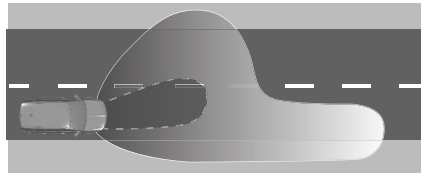

Activated automatically when the following conditions are met:

- the vehicle speed is between 0 km/h and 70 km/h,

- the rear fog light is off,
- the windscreen wipers are activated for more than two minutes.

The light is widened to better recognise the lane markings and the low beam is dimmed to avoid dazzling the oncoming traffic.

Fog mode

Activated automatically when the rear fog light is switched on. This mode is designed to enhance driver visibility in foggy conditions.

Cornering light



Activated at a speed of up to approx. 40 km/h when turning off. Depending on the steering wheel angle and the turn lights, a particular LED light function is triggered which illuminates the direction of travel.

Curve light

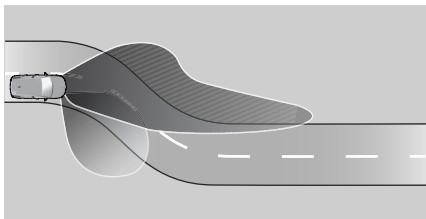

Particular LEDs, based on steering angle and speed, are additionally triggered to improve lighting in curves. This function is activated at speeds up to approx. 70 km/h.

Glare-free high beam

⚠ Warning

The glare-free high beam function may dazzle other drivers when the vehicle is used in countries with opposite-side traffic, e.g., a left-hand drive vehicle driven in a right-hand drive country.

Switch off glare-free high beam function whenever you are driving in countries mentioned above.

This feature allows high to function as main driving light in dark surroundings.

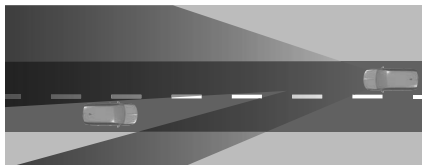

The beam is dynamically shaped depending on driving conditions. This gives the best light distribution without dazzling other road users.

Glare-free high beam is switched on automatically at a speed above 45 km/h. It is switched off at a speed below 35 km/h, but remains in standby mode.

Motorway mode

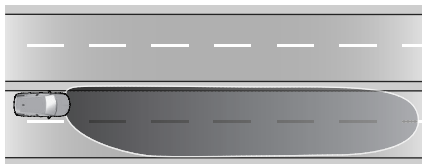

Activated automatically when highway driving is detected. Illumination is

adapted to the higher speed driven on motorways and to avoid dazzling drivers in the oncoming lanes. When following vehicles ahead or passing, dazzling for these vehicles is reduced.

Traffic sign anti-glare

Activated automatically. This mode is designed to minimise glare from traffic signs.

Fault in LED headlight system

When the system detects a failure in the LED headlight system, it selects a preset position to avoid dazzling oncoming traffic. A warning is displayed in the cluster.

If the fault is still displayed on the next ignition cycle, consult a qualified workshop.

PARKING LIGHTS

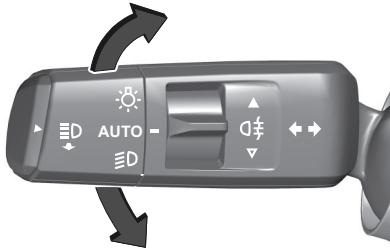

When the vehicle is parked, the parking lights on one side can be activated:

1. Switch off the ignition.
2. Move the lever all the way up (right parking lights) or down (left parking lights).

Confirmed by an audible chime and the corresponding turn light control indicator.

MISTED LIGHT COVERS

The inside of the light housing may mist up briefly in poor, wet and cold weather conditions, in heavy rain or after washing. The mist disappears quickly by itself. To help, switch on the headlights.

Interior lights

COURTESY LIGHTS

Depending on version, press or touch the button to activate the corresponding courtesy light.

Front courtesy lights



Rear courtesy lights

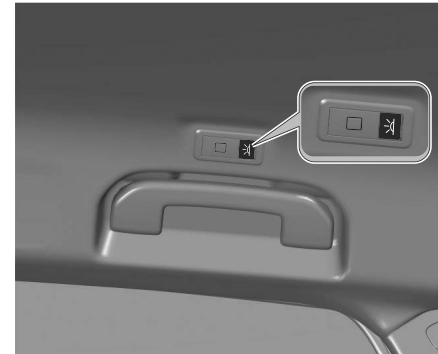

INSTRUMENT PANEL LIGHTING

The brightness of the following lights can

be adjusted in the settings app  in the Info Display when the exterior lights are on:

- instrument panel illumination
- Info Display
- illuminated switches and operation elements

Lighting features

CENTRE CONSOLE LIGHTING

A spotlight integrated in the overhead console illuminates the centre console when headlights are switched on.

ENTRY LIGHTING

Welcome lighting

Some or all of the following lights are switched on for a short time by unlocking the vehicle with the radio remote control:

- headlights
- interior lights
- turn lights
- sidelights

The lighting switches off immediately when the ignition is switched on.

The function can be activated or

deactivated in the settings app  in the Info Display.

The following lights will additionally switch on when the driver's door is opened:

- illumination of some switches

- cluster
- door pocket lights

EXIT LIGHTING

The following lights are switched on when the ignition is switched off:

- headlights
- interior lights
- centre console lighting

They will switch off automatically after a delay.

The function can be activated or

deactivated in the settings app  in the Info Display.

VEHICLE LOCATOR LIGHTING

This function makes it possible to locate the vehicle, e.g., in weak lighting conditions, using the remote control.

Press  on the remote control, an eye-catching animation will play.

BATTERY DISCHARGE PROTECTION

To prevent discharge of the vehicle battery when the ignition is switched off, some interior lights are switched off automatically after some time.

Sunroof

Warning

Take care when operating the sunroof. Risk of injury, particularly to children. Keep a close watch on the movable parts when operating them. Ensure that nothing becomes trapped in them as they move.

Attention

Do not operate the sunroof if a roof rack is fitted. Do not place heavy loads on the movable parts of the sunroof.

Switch on ignition to operate the sunroof.

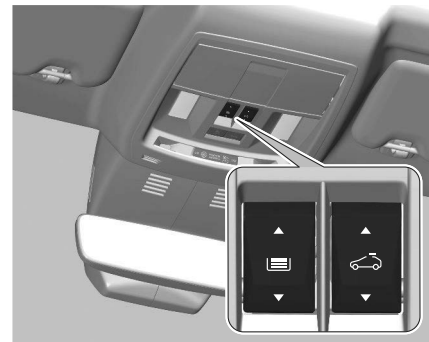

: Sunroof blind control

: Sunroof control

Open or close

- To open the sunroof or the blind, use the part of the button located towards the rear.
- To close the sunroof or the blind, use the part of the button located towards the front.

Operation of buttons

- Pressing a button beyond its point of resistance directly opens or closes the sunroof or blind fully.
- Pressing the button again stops the current movement.
- When holding a button (without going beyond the point of resistance), the movement of the sunroof or blind stops when this button is released.
- When the sunroof is closed: pressing once without passing the point of resistance moves it to a partially open position.

General hints

Safety function

If the sunroof encounters resistance during automatic closing, it is immediately stopped and opened again.

Override safety function

In the event of closing difficulties, e.g.

due to frost, press and hold .

The sunroof closes with safety function disabled. To stop movement, release the switch.

Closing sunroof from outside

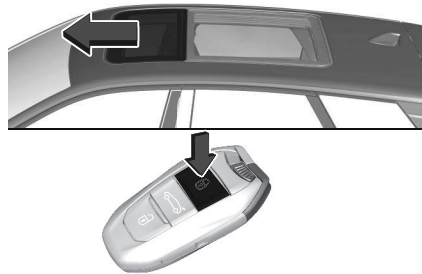

The sunroof can be closed remotely from outside the vehicle.



Press and hold  for more than two seconds to close the sunroof. Release the button to stop the movement.

Initialising the sunroof

If the automatic operation of the sunroof is not possible, the sunroof has to be initialised:

1. Switch on ignition.
2. Press and hold  to close the sunroof.
When it is completely closed, a short opening and closing motion takes place.
3. Only release  one second after this motion has finished.

Interior storage

STORAGE COMPARTMENTS

Warning

Do not store heavy or sharp objects in the storage compartments.

Glove box



The glove box should be closed whilst driving.

Centre console storage

The centre console features a big storage space including a removable bin.

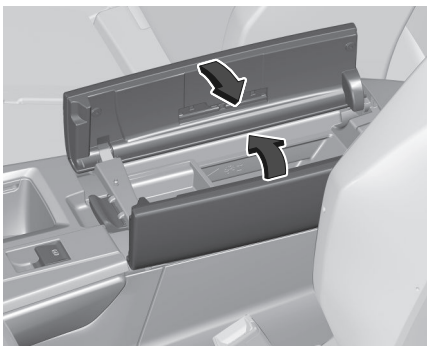

A storage compartment for inductive charging and USB sockets is located beneath the instrument panel.

Depending on version, the storage compartment may have a sliding cover and a cable pass through that grants access to storage in the second row centre console.

Slide the cover forwards.

Inductive charging ⇒ page 65

USB PORT ⇒ page 66

Door panel storage

A storage compartment is located in the front and rear door panels.

Seat storage pockets

The front seats feature storage pockets on their rear side, accessible to the second row occupants. Depending on the version, an additional pocket may be available on the upper part of the seat.

Rear floor storage cover

Raise the cover at the recess to gain access to emergency breakdown equipment.

Tyre repair kit ⇒ page 181.

Spare wheel ⇒ page 178.

Double load floor

The double load floor can be inserted in the load compartment in two positions:

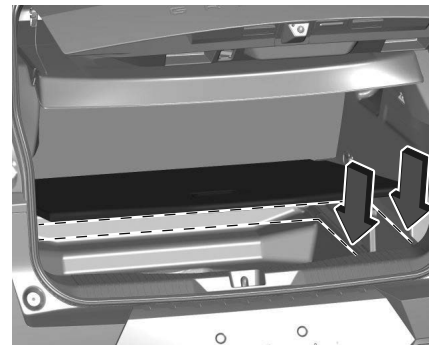

- lower position above the rear floor storage cover
- upper position interlocked with the grab handle into back panel trim

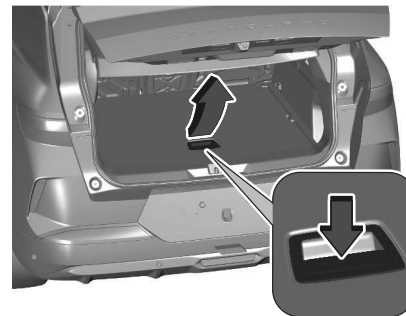

To remove, press the handle to unlock the load floor and lift it up while using the handle.

If mounted in the upper position, the space between the load floor and the spare wheel well cover can be used as a storage compartment.

In this position, if the rear seat backrests are folded forwards, an almost completely flat load bay is created.

In the upper position, the double load floor is able to withstand a maximum load of 100 kg. In the lower position, the double load floor is able to withstand the maximum permissible load.

CUP HOLDERS

Cup holders are located in the centre console between the front seats.



The rear cup holders are located in the armrest between the seats. Fold down the armrest.

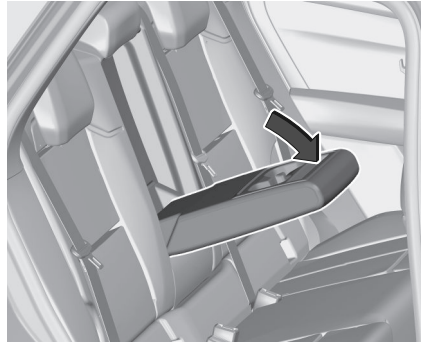

LASHING EYES

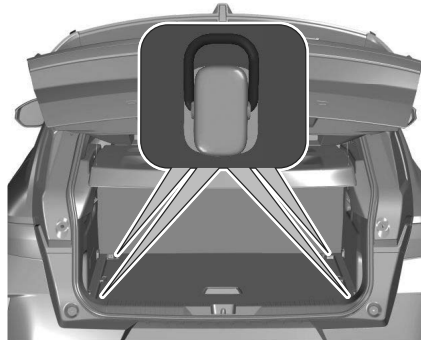

The lashing eyes are designed to secure items against slippage, e.g.

using lashing straps or luggage net.

SAFETY NET

The safety net can be installed behind the rear seats or, if the rear seat backrests are folded, behind the front seats. Passengers must not be transported behind the safety net.

Installation

Behind the rear seats

Remove the roller blind.

Load compartment cover ⇒ page 57

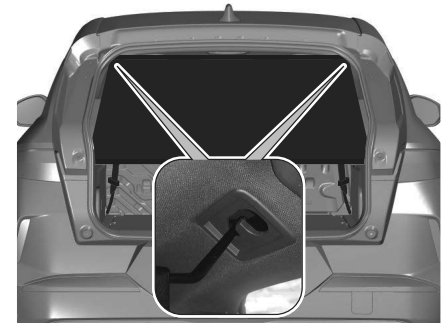

- There are installation openings on both sides in the roof frame above the rear seats: suspend and engage rod of net at one side, compress rod and suspend and engage at the other side.



- Attach the hooks of the safety net straps in the lashing eyes behind the rear seats.
- Tension both straps by pulling at the loose end.
- Rear seat backrests must be raised up.

Behind the front seats

- Push down head restraints and fold down the rear backrests.

Load compartment ⇨ page 57



- Insert the hooks of the safety net straps into the buckles on the back side of the rear backrests.
- Tension both straps by pulling at the loose end.

WARNING TRIANGLE

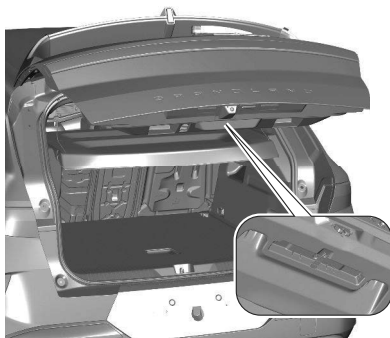

Stow the warning triangle in the space at the rear of the tailgate and secure it with the Velcro® fastener.

FIRST AID KIT

Depending on version, a first aid kit may be located in the boot.

LOADING INFORMATION

Warning

Always make sure that the load in the vehicle is securely stowed.

Otherwise objects can be thrown around inside the vehicle and cause personal injury or damage to the load or car.



- Heavy objects in the load compartment should be placed against the seat backrests. Make sure that the backrests are securely engaged ⇒ page 57. If objects can be stacked, heavier objects should be placed at the bottom.
- Prevent sliding of loose objects by securing them with straps attached to the lashing eyes ⇒ page 53.
- Do not allow the load to protrude above the upper edge of the backrests.
- Do not place any objects on the load compartment cover or the cluster, and do not cover the sensor on top of the instrument panel.
- The load must not obstruct the operation of the pedals, parking brake and gear selector, or hinder the

freedom of movement of the driver. Do not place any unsecured objects in the interior.

- Do not drive with an open load compartment.
- The payload is the difference between the permitted gross vehicle weight (see identification plate ⇒ page 202.) and the EC kerb weight.

To calculate the payload, enter the data for your vehicle in the weights table at the front of this manual.

The EC kerb weight includes weights for the driver (68 kg), luggage (7 kg) and all fluids (fuel tank 90% full).

Optional equipment and accessories increase the kerb weight.

- Driving with a roof load increases the sensitivity of the vehicle to cross-winds and has a detrimental effect on vehicle handling due to the vehicle's higher centre of gravity.

Distribute the load evenly and secure it properly with retaining straps. Adjust the tyre pressure and vehicle speed according to the load conditions. Check and retighten the straps frequently.

Do not drive faster than about 74 mph.

The permissible roof load is 60 kg. The roof load is the combined weight of the roof rack and the load.

VEHICLE LOADING

Roof bars

Warning

As a safety measure and to avoid damaging the roof, it is essential to use transverse roof bars approved for your vehicle.

Observe the instructions on fitting and use contained in the guide supplied with the roof bars.

⚠ Warning

Maximum load distributed over the transverse roof bars, for a loading height not exceeding 40 cm (except bicycle carrier): **80 kg**.

As this value may change, please verify the maximum load quoted in the guide supplied with the roof bars.

If the height exceeds 40 cm, adapt the speed of the vehicle to the profile of the road, to avoid damaging the roof bars and the fixings on the vehicle.

Be sure to refer to national legislation in order to comply with the regulations for transporting objects that are longer than the vehicle.

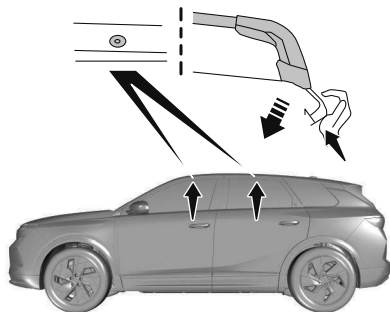
Direct fitting on roof

The transverse bars must only be fixed at the four anchorage points located on the roof frame.

These points are concealed by the vehicle doors when the doors are closed.

The roof bar fixings have a stud which must be inserted into the opening of each anchorage point.

⚠ Warning**Recommendations**

Distribute the load uniformly, taking care to avoid overloading one of the sides.

Arrange the heaviest part of the load as close as possible to the roof.

Secure the load firmly.

Drive gently: the vehicle will be more susceptible to the effects of side winds and its stability may be affected.

Regularly check the security and tight fastening of the roof bars, at least before each trip.

Remove the roof bars once they are no longer needed.

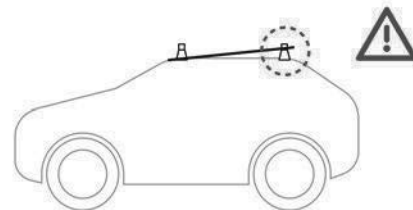
**⚠ Warning****Sunroof**

If the sunroof remains open, the vehicle is locked with exterior perimeter monitoring activated but without interior volumetric or anti-tilt monitoring.

Load reduction mode

This system manages the use of certain functions according to the level of charge remaining in the battery.

When the vehicle is being driven, the load reduction function temporarily deactivates certain functions, such as the air conditioning and the heated rear screen.

The deactivated functions are reactivated automatically as soon as conditions permit.

Load compartment

TAILGATE

Opening

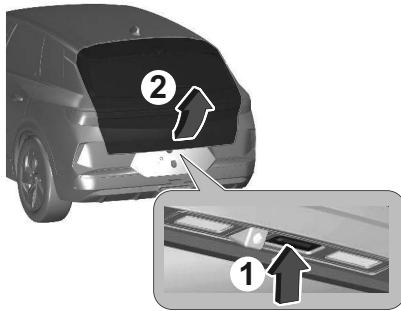

1. Press the button behind the lower centre edge of the tailgate.
2. Open the tailgate.

Closing

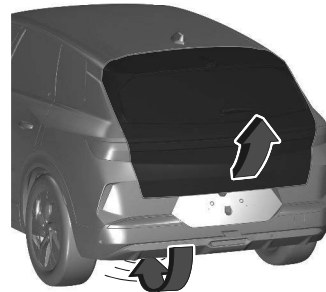

Use the interior handle.

Central locking system ⇒ page 8

POWER TAILGATE



CAUTION

Take care when operating the power tailgate. Risk of injury, particularly to children. Keep a close watch on the movable tailgate when operating. Ensure that nothing becomes trapped during operating and no one is standing within the moving area.

Note

The power tailgate will be deactivated if a trailer is connected to the socket of the trailer hitch.

The power tailgate can be operated by:

- Pressing  on the electronic key.
To prevent unintended opening of the tailgate,  must be pressed longer than during locking or unlocking.
- Hands-free operation with motion sensor below the rear bumper.
- The tailgate button under the exterior tailgate moulding and C in the open tailgate.
- Pressing  twice next to the steering wheel.

The tailgate can be operated when the vehicle is stationary and P engaged, or if the driver is sitting in the car, engine running, D is engaged, but the car is stationary and the driver pressing the brake. The power tailgate can be adjusted in the Info Display.

Vehicle personalisation ⇒ page 71



Note

Operating the power tailgate does not operate the central locking system. To open the tailgate with the button on the electronic key, or with the tailgate button or via hands-free operation, it is not necessary to unlock the vehicle. A precondition is that the electronic key is outside the vehicle, within a range of approx. 1 m of the tailgate.

Do not leave the electronic key in the load compartment. Lock the vehicle after closing if it was unlocked previously.

Central locking system ⇨ page 8

Operation with the electronic key

Press and hold  to open or close the tailgate. To prevent unintended opening of the tailgate,  must be pressed longer than during locking or unlocking.

Hands-free operation with motion sensor below the rear bumper



To open or close the tailgate, move the foot back and forth in the area shown in the illustration. Do not hold

the foot longer or move too slow below the bumper. The electronic key must be outside the vehicle, within a range of approx. 1 m of the tailgate. The turn lights will flash to indicate the power tailgate movement. The hands-free operation can be adjusted in the Info Display.

Vehicle personalisation ⇨ page 71

DANGER

Do not touch any vehicle parts below the vehicle during hands-free operation. There is a risk of injury from hot engine parts.

Operation with the tailgate button under the exterior tailgate moulding

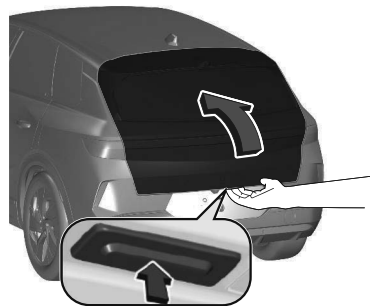



To open the tailgate, press the tailgate button under the tailgate moulding until the tailgate starts to move. If the vehicle is locked, the electronic key must be outside the vehicle, within a range of approx. 1 m of the tailgate.



To close, press  in the open tailgate until the tailgate starts to move.

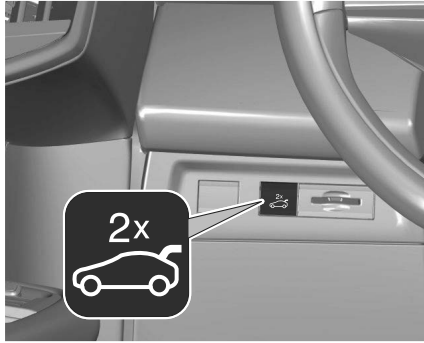

Operation with the button next to the steering wheel



Press  twice to open the tailgate.

Stop or change direction of movement

To stop movement of the tailgate immediately:

- press  once on the electronic key, or
- press the tailgate button under the exterior tailgate moulding, or
- press  on the open tailgate, or
- press  next to the steering wheel.

Pressing one of the switches again will reverse the direction of movement.

Memorising an opening height

To memorise a desired opening height, move the tailgate to the desired position and press one of the following buttons for more than three seconds:

-  in the open tailgate
- the button under the tailgate moulding

The adjusted memorisation will be confirmed by a chime. A new memorisation cancels the previous one.

Note

Adjusting opening height should be programmed at ground level.

Safety function

If the power tailgate encounters an obstacle during opening or closing, the direction of movement will automatically be reversed slightly. Multiple obstacles in one power cycle will deactivate the function. In this case, close or open the tailgate manually to reactivate the power tailgate. The power tailgate has pinch sensors on the side edges. If the sensors detect obstacles between tailgate and chassis, the tailgate will open, until it is activated again or closed manually. The safety function is indicated by a warning chime. Remove all obstacles before resuming normal power operation. If the vehicle is equipped with factory-fitted towing equipment and a trailer

is electrically connected, the power tailgate can only be opened with the tailgate button or closed with  in the open tailgate. Ensure that there are no obstacles in the moving area.

Overload

If the power tailgate is repeatedly operated at short intervals, the function is disabled for some time. Move tailgate manually into end position to reset the system.

GENERAL HINTS FOR OPERATING TAILGATE

DANGER

Do not drive with the tailgate open or ajar, e.g. when transporting bulky objects, since toxic exhaust gases, which cannot be seen or smelled, could enter the vehicle. This can cause unconsciousness and even death.

Attention

Before opening the tailgate, check overhead obstructions, e.g. a garage door, to avoid damage to the tailgate. Always check the moving area above and behind the tailgate.

Attention

Do not install any carrier onto the tailgate.

Note

At low outside temperatures the tailgate may not open fully by itself. In this case lift the tailgate manually to its normal end position.

Back-up release

To manually unlock the boot in the event of a battery or central locking failure.

Unlocking

- Fold the rear seats to gain access to the lock from inside the boot.

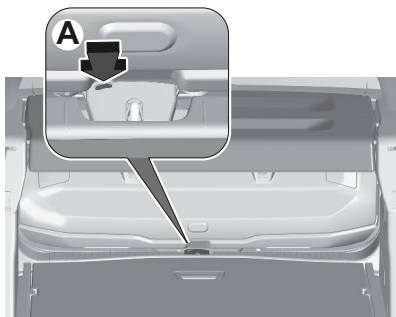

- Insert a small screwdriver into hole A of the lock to unlock the boot.
- Move the latch to the left.

Locking after closing

If the fault persists after closing again, the boot will remain locked.

12 V accessory socket

- To connect a 12 V accessory (maximum power: 120 W), lift the cover and plug in a suitable adaptor.
- Switch on the ignition.

⚠ Warning
<p>The connection of an electrical device not approved by the Manufacturer, such as a USB charger, may adversely affect the operation of vehicle electrical systems, causing faults such as poor radio reception or interference with displays in the screens.</p>

Storage well

- Lift the boot floor as far as possible or lift the hinged boot carpet (depending on version) to access the storage well.

Depending on version, it includes:

- A hazard warning triangle.
- A temporary puncture repair kit with the tool kit.
- A spare wheel with the tool kit.
- The traction battery charging cables (electric).

Boot light

It comes on automatically when the tailgate is opened and goes off automatically when the tailgate is closed.

The lighting time varies according to the circumstances:

- When the ignition is off, approximately 10 minutes.
- In energy saving mode, approximately 30 seconds.
- With the engine running, unlimited.

Bonnet

OPENING / CLOSING

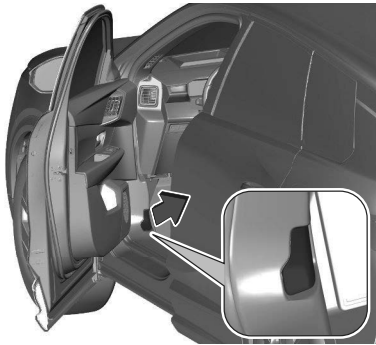

- Open the left-hand front door.
- Pull the release lever, located at the bottom of the door frame, towards you twice to unlock the bonnet.
- Pull the interior release lever towards you twice to unlock the safety catch.

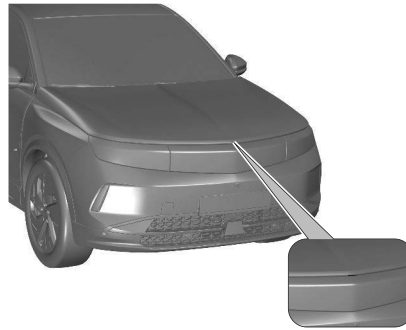

- Raise the bonnet.
- Unclip the stay from its housing and place it in the support slot to hold the bonnet open.

Closing

- Lower the bonnet and release it near the end of its travel.
- Check the locking.

Warning

Because of the presence of electrical equipment under the bonnet, it is strongly recommended that exposure to water (rain, washing, etc.) be limited.

Dashboard instruments and control

Instrument panel overview.....	63
Pedestrian safety alert.....	64
Digital speedometer.....	64
Engine coolant temperature gauge	64
Engine oil level monitor.....	65
Inductive charging.....	65
12 V power outlet.....	66
USB port.....	66
Vehicle customisation.....	67
Telematics services.....	67
Displays.....	68
Instrument cluster.....	68
Information display.....	68
Pure Mode.....	69
Vehicle customisation.....	71
Odometer.....	71
Trip odometer.....	71
Service display.....	71
Outside temperature.....	72
High-voltage battery gauge.....	72
Vehicle range.....	72
Power indicator gauge.....	72
Fuel gauge.....	73
Vehicle messages.....	73
Warning chimes.....	73
Warning and control indicator lights	74

Turn lights.....	76
Seat belt reminder.....	76
Airbag and belt tensioners.....	76
Airbag deactivation.....	77
Charging system.....	77
Fault indicator light.....	77
Service vehicle soon.....	77
Stop engine.....	77
System check.....	78
Hybrid system fault.....	78
Brake and clutch system.....	78
Parking brake.....	78
Electric parking brake fault.....	78
Anti-lock brake system (ABS).....	78
Gear shifting.....	78
Power steering.....	78
Lane Keeping Assist.....	78
Parking Assist.....	79
Electronic stability control and anti-slip regulator.....	79
Engine coolant temperature.....	79
Exhaust filter.....	79
Tyre deflation detection system.....	79
Engine oil pressure.....	80
Low fuel.....	80
Vehicle ready.....	80
Reduced engine power.....	80
High-voltage battery temperature high	80
Autostop.....	80
Exterior light.....	80
Low beam.....	81
High beam.....	81

High beam assist.....	81
Rear fog light.....	81
Rain sensor.....	81
Pedestrian safety alert fault.....	81
Active emergency braking.....	81
Traffic sign assistant.....	81
Driver drowsiness detection.....	81
Door open.....	82
e-SAVE Function.....	82

Instrument panel overview

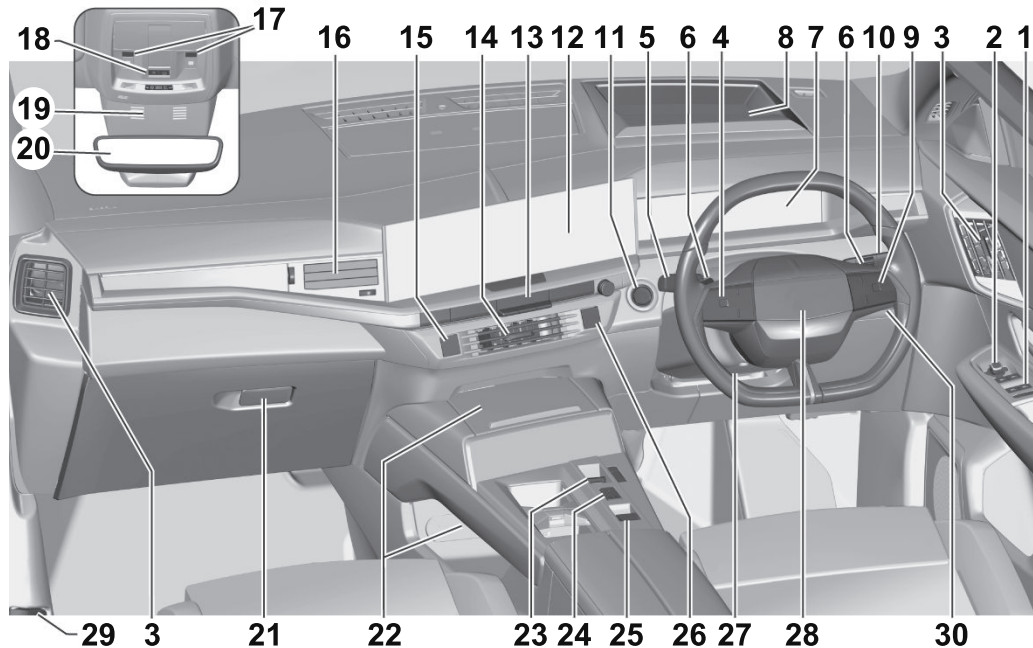

1 Power windows ⇒ page 14

2 Exterior mirrors/eHUD control ⇒
page 16

3 Side air vents

4 Cruise control, speed limiter,
adaptive cruise control

5 High beam, headlight flash, turn
lights, rear fog light, parking lights,
cluster pages

6 Steering wheel paddles

7 Cluster ⇒ page 68

8 Extended head-up display (eHUD)

9 Infotainment controls ⇒ page 83

10 Windscreen wiper and washer ⇒
page 42, rear window wiper and
washer ⇒ page 43

- 11 Power button
- 12 Info Display⇒ page 68
- 13 Climate control
- 14 Centre air vents
- 15 Hazard warning flashers⇒ page 176
- 16 Centre air vents
- 17 Interior lights⇒ page 49
- 18 Emergency call⇒ page 176
- 19 Seat belt reminder⇒ page 76, airbag deactivation⇒ page 30
- 20 Interior mirror⇒ page 16
- 21 Airbag deactivation⇒ page 30, glovebox
- 22 12 V power outlet⇒ page 66, USB ports⇒ page 66
- 23 Gear selection, selector lever
- 24 Drive modes⇒ page 118
- 25 Parking brake⇒ page 78
- 26 Central locking button ⇒ page 8
- 27 Steering wheel adjustment ⇒ page 40
- 28 Horn⇒ page 41

- 29 Bonnet release lever ⇒ page 61
- 30 Headlight range adjustment, heated windscreen, power tailgate, fuel filler flap, anti-theft alarm system status LED, coin holder

PEDESTRIAN SAFETY ALERT

The sound of the pedestrian safety alert is generated to indicate the vehicle presence to pedestrians. It is active up to 19 mph.

DIGITAL SPEEDOMETER

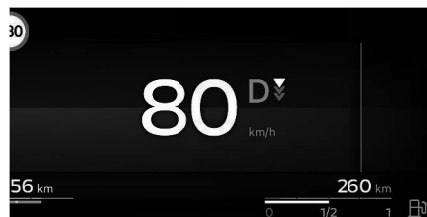

Indicates the vehicle speed.

ENGINE COOLANT TEMPERATURE GAUGE



Displays the coolant temperature.

- 50** : engine operating temperature not yet reached
- 90** : normal operating temperature
- Top of the gauge** : temperature too high

Control indicator  illuminates red if engine coolant temperature is too high.

CAUTION

If the engine coolant temperature is too high, stop the vehicle, switch off the engine. Danger to the engine. Check the coolant level.

ENGINE OIL LEVEL MONITOR

The state of the engine oil level is displayed in the cluster for a few seconds following the service information after switching on the ignition.

A proper state of engine oil level is indicated by a message.

If the engine oil level is low, the two indicators  flash and a message is indicated.

Confirm the engine oil level by using the dipstick and top up engine oil respectively.

Engine oil ⇨ page 65.

A fault of measurement is indicated by a message. Check the engine oil level manually by using the dipstick.

INDUCTIVE CHARGING

Warning

Inductive charging can affect the operation of implanted pacemakers or other medical devices. If applicable, seek medical advice before using the inductive charging device.

Warning

Remove any metal objects from the charging device before charging a mobile device, as these objects could become very hot.

This system allows wireless charging of a mobile device such as a smartphone, using the magnetic induction principle, in accordance with the Qi standard.

The mobile device to be charged must be compatible with the Qi standard, either by design or by using a compatible holder or shell.

To charge a mobile device:

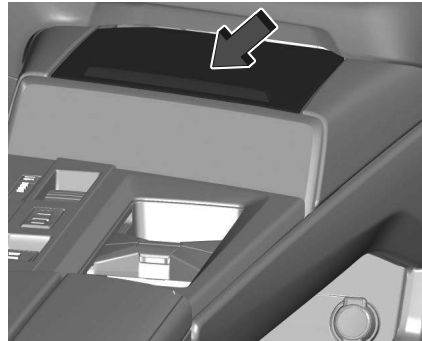

1. Remove all objects from the charging device.

2. Place the mobile device on the charging area. Note that the mobile device must be placed between the positioning aids.

On some mobile devices, a back cover with an integrated coil or a jacket may be required to use inductive charging.

A protective cover for the mobile device could have impact on the inductive charging.

In the event that the mobile device is not charging properly, rotate it 180° and place it on the charging device again.

Status LED

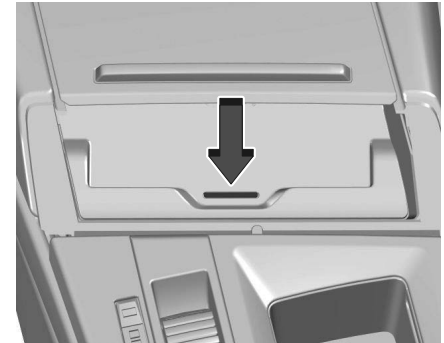

The LED indicates the current charging status.

Illuminates green

The mobile device is charging.

Flashes yellow

The mobile device has not been centred properly in the charging zone or an unknown object has been detected in the charging zone.

Illuminates yellow

There is a problem with the mobile device's battery or a fault of the inductive charger has been detected.

If the problem persists, seek the assistance of a workshop.

12 V POWER OUTLET

A 12 V power outlet is located in the front centre console.

Depending on version, another 12 V power outlet is located at the rear centre console and in the load compartment.

Plug in a 12 V accessory (with a maximum rated power of 120 W) using a suitable adapter.

Observe the maximum power rating to avoid damaging the accessory.

Do not exceed the maximum power consumption of 120 W.

The 12 V power outlet is deactivated in the event of low vehicle battery voltage.

Electrical accessories that are connected must comply with the electromagnetic compatibility requirements laid down in DIN VDE 40 839.

Do not connect any current-delivering accessories, e.g. electrical charging devices or batteries.

Do not damage the outlet by using unsuitable plugs.

USB PORT

These symbols determine the type of use of a USB socket:



Power supply and recharging.



To connect a portable device to the Infotainment system, use this port



Likewise, plus use of smartphone applications with the touch screen.

Depending on version, the vehicle is fitted with two USB sockets in the storage compartment beneath the instrument panel.

Two USB sockets on the 2nd row.

Note

The sockets must always be kept clean and dry.

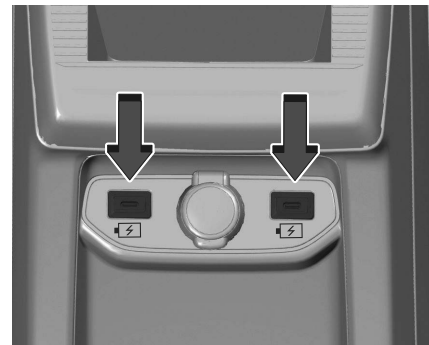
Rear USB port

The USB port can be used to charge a portable device.

VEHICLE CUSTOMISATION

The vehicle's behaviour can be personalised by changing the settings in the Info Display.

Some functions are only displayed or active when the engine is running.

TELEMATICS SERVICES

Vauxhall Connect

Vauxhall Connect comprises multiple connected services accessible via app, online or within the vehicle.

Note

Full functionality of Vauxhall Connect is subject to registration and proper activation.

Connected services may include live navigation such as online traffic information and vehicle status and information such as maintenance alerts.

Services accessible within the vehicle also include emergency call and breakdown call. These functions are automatically activated. Terms and conditions apply.

Emergency call ⇨ page 176.

Breakdown call

Pressing the button in the overhead console for more than two seconds connects to a roadside assistance service provider.

For information about coverage and scope of services of the roadside assistance, please refer to the information provided by the Vauxhall Retailer with the order form.

Privacy settings

Privacy settings of Vauxhall Connect can be configured. This will impact the set of data being sent, e.g., in case a breakdown call is triggered.

The emergency call function and the traffic sign assistant will not be impacted.

Privacy settings also affect MyVauxhall.

Depending on version, the privacy settings can be changed by simultaneously pressing the button and SOS in the overhead console or via the system settings menu in the Info Display.

Status LED in the overhead console

Illuminates green and red and extinguishes after a short time, when the ignition is switched on: the system works properly.

Illuminates red: fault in the system.

Contact a workshop.

Flashes red: backup battery needs replacement. Contact a workshop.

Emergency call

The emergency call function will establish a connection to the nearest public safety answering point (PSAP).

A minimum set of data including vehicle and location information will be sent to the PSAP.

In case of an emergency, press the red **SOS** button in the overhead console for more than two seconds.

The LED flashes green to confirm that a connection to the nearest PSAP is being established. The LED illuminates steadily as long as the call is active.

Pressing the **SOS** button immediately a second time will terminate the call.

The LED switches off.

Automatic crash notification

In case of an accident with airbag deployment and without damage of needed hardware, an automatic emergency call is established and an automatic crash notification will be transmitted to the next PSAP.

Displays

INSTRUMENT CLUSTER

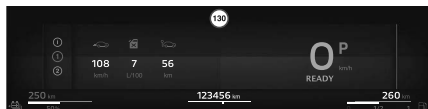

In addition to warning lights, gauges and indicators, the following information is available:

- trip odometer
- gear shift indication
- service information

- vehicle and warning messages
- driver assistance messages
- pop-up messages
- infotainment information



Press the button to scroll through the pages or to close a pop-up message.

Vehicle settings and driving functions

Select one of the following settings:

- Driving assistance
- User settings



Short press: select or confirm a menu or setting.



Long press: resetting the service reminder.



: scroll through the settings menus.

INFORMATION DISPLAY

The cluster is located on the cluster near the instrument cluster.

The cluster can indicate:

- time

- outside temperature
- date
- Infotainment system, see description in the Infotainment system section ⇒ page 83
- indication of rear view camera ⇒
- indication of parking assist instructions ⇒ page 155
- navigation, see description in the Infotainment system section ⇒ page 93
- vehicle and system messages ⇒ page 73.
- settings for vehicle personalisation ⇒ page 67.

Head Up Display

This extended head-up display system projects information onto the windscreen in the driver's field of vision so that they do not need to take their eyes off the road.

Warning

No object must be placed in the cavity - risk of damaging the system!

Tip

For optimum use, consider adjusting the driver's seat and the height of the extended head-up display.

To adjust the position of the HUD, rotate the mirror adjustment knob to the forward position and tilt the knob to set the HUD to the desired position.

Brightness is adjusted using the brightness settings in the Settings page of the infotainment screen.

Contents of the HUD can be set using the page customisation settings in the infotainment display.

Vehicle personalisation ⇒ page 67

Tip

In certain extreme weather conditions (e.g. rain and/or snow, bright sunlight) and when wearing polarised sunglasses, the extended head-up display may not be legible or may be momentarily obscured.

Tip

The Extended Head Up Display is associated with a specific windscreen approved by the Manufacturer.

If the windscreen is replaced outside the dealer network, follow the Manufacturer's recommendations.

PURE MODE

Pure Mode is a special mode designed to display only the essential information to let the driver focus on demanding traffic environments.

It can be switched to manually, automatically, or following a prompt to the driver when certain time and speed conditions apply.



The mode is indicated by the  icon located at the bottom of the cluster and on the top of the central screen (next to the page indicators).

Pure Mode uses the shortcut page on the Info Display. Information on the cluster is reduced to the essential information.

Settings

Settings can be changed in the Customisation menu of the vehicle settings. Selecting "Pure Mode" gives access to the following items:

- Conditions to Switch:
 - Speed: Enables/Disables the speed condition for Pure Mode.
 - Time Frame: Enables/Disables the time-related conditions for Pure Mode.

- Automatic: the system switches to Pure Mode after a customisable delay following detection of low light conditions (e.g. sunset).
- Custom: the system switches to Pure Mode when the onboard time is within a custom time frame set by the user.
- Confirmation:
 - Switch automatically: when selected, the system will switch to Pure Mode automatically when the conditions are met, without prompting the driver.
 - Ask before switching: when enabled, if the system detects that the conditions for Pure Mode are met, it will prompt the driver to switch.

Activation

It is possible to activate the mode through:

- Setting the system to switch automatically or accepting the prompted pop-up on the cluster or the HUD (if equipped and activated)

The pop-up will appear when:

- Vehicle speed exceeds the set threshold

- The set amount of time after sunset has elapsed or the time is within the set time frame
- Opening the leftmost homepage (Pure Mode) by swiping to the right on the Info Display, or pressing on the left stalk for over 2 seconds



When the pop-up appears, press on the right steering wheel control to toggle between "Yes" and "No". Confirm

the selection by pressing



To dismiss the pop-up, either press the left stalk button, press "No" or wait a few seconds.

Deactivation

The mode cannot be automatically turned off. It is possible to exit the mode through:

- Swiping to the left on the Info Display, or
- A short press on left stalk, or



- Home button

Fault

If speed or time of day data is not accessible, it will not be possible to automatically switch to Pure Mode.

It is still possible to activate the mode manually.

Standby Mode

When in standby mode, the HUD and cluster will show the Pure Mode.

However, switching to and from Pure Mode via a swipe on the infotainment screen is not possible.

Switching back from Pure Mode to normal mode will not change mode of the infotainment screen.

Screen mirroring

When in Pure Mode, the driver can still use the mirroring feature. When it is active, the Pure Mode apps on the infotainment screen are replaced by the mirroring apps.

Shortcuts

Shortcuts of the Pure Mode home page are customisable when the Home Page on the central screen contains a grid of six shortcuts.

Personalisation ⇒ page 88

A long press on the icons will not customise/replace the shortcuts. The system will lead to a tutorial pop-up with a QR code to scan.

VEHICLE CUSTOMISATION

The vehicle's behaviour can be personalised by changing the settings in the Info Display.

Some functions are only displayed or active when the engine is running.

Odometer



The total recorded distance of the vehicle is displayed in the right bottom corner of the cluster (MHEV/PHEV), or the bottom left corner (BEV).

TRIP ODOMETER

The following trip odometer pages are selectable in the trip/autonomy information menu or by pressing the right stalk button:

- Trip in progress with instantaneous fuel consumption
- Trip 1 or 2 with average consumption, average speed and trip distance

Hybrid 48 V vehicle: the distance percentage of electric driving is shown additionally.

Service display

The service system informs the driver when to change the engine oil and filter or a vehicle service is required. Based on driving conditions, the interval at which an engine oil and filter change is required can vary considerably.

A required service due is displayed in the cluster for several seconds after switching on the ignition.

If no service is required for the next 1800 miles or more, no service information appears in the display.

If service is required within the next 1800 miles, the remaining distance or time duration is indicated for several seconds.

Simultaneously indicator  illuminates permanently as reminder.

If service is required in less than 620 miles, indicator flashes and then illuminates permanently. The remaining distance or time duration is indicated for several seconds.

Overdue service is indicated by a message in the cluster that indicates the overdue distance. The indicator flashes and then illuminates permanently until service is executed.

Reset of service interval

After each service, the service indicator must be reset to ensure proper functionality. It is recommended to seek the assistance of a workshop.

Operate as following:

- Switch off the ignition.



- Press and hold left stalk button to reset the service interval
- Trip odometer can be reset by pressing the right stalk button.

Retrieving service information

To retrieve the status of the service information at any time:

- Press the end of the right stalk to access the menu.

- Scroll through the pages using the steering wheel toggle up and down.
- Short-press on the toggle when in the service menu.

The service information is displayed for a few seconds.

Outside temperature

The outside temperature is shown on the cluster display or in the status bar of the Info Display.

High-voltage battery gauge



Displays the high-voltage battery state of charge.

Vehicle range

Displays the total vehicle range.

POWER INDICATOR GAUGE

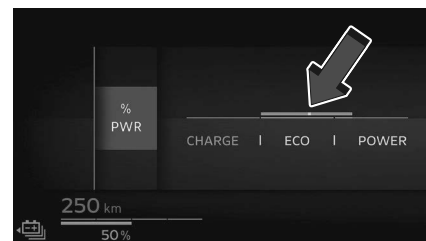

The power indicator gauge informs about the current energy situation of the vehicle.

Power : Energy consumption during high power demand. Hybrid 48 V vehicles: ICE and electrical engine work combined.

Eco : An optimum in energy is accessible in all drive modes. Hybrid 48 V vehicles: optimum usage of ICE or electric engine.

Charge : Battery is being charged with energy resulting from braking or deceleration of the vehicle.

FUEL GAUGE



Displays the fuel level in the tank.

Control indicator  illuminates if the level in the tank is low.

Never run the fuel tank dry.

The top-up quantity may be less than the specified fuel tank capacity, due to the remaining fuel in the tank.

Vehicle messages

Messages are indicated in the information cluster, in some cases together with a warning chime.



Press to confirm a message.

Vehicle and service messages

The vehicle messages are displayed as text. Follow the instructions given in the messages.

Messages in the information cluster

Some important messages may appear additionally in the Info Display. Some messages only pop-up for a few seconds.

Vehicles with navigation system

The vehicle recognises low emission zones. An audible message is given when entering or exiting a low emission zone and an icon will be shown on the navigation map.

WARNING CHIMES

The warning chime regarding not fastened seat belts has priority over any other warning chime.

Whenever a warning chime sounds, pay attention to the messages displayed and the warning lights on the information cluster.

When a failure is detected in the sound module  appears on the cluster accompanied by a display message. No warning chime will sound, also not for the driver assistance system.

When starting the engine or whilst driving

A warning chime will sound in situations such as

- a seat belt is not fastened
- a door or the tailgate is not fully closed
- a certain speed is exceeded with parking brake applied
- cruise control deactivates automatically
- a programmed speed or speed limit is exceeded
- a warning message appears on the cluster

- the electronic key is not in the passenger compartment
- the parking assist detects an object
- an unintended lane change occurs
- the exhaust filter has reached the maximum filling level
- hands-off driving is recognised
- drowsiness of the driver is recognised
- a vehicle directly ahead is approached too quickly

When the vehicle is parked and / or the driver's door is opened

A warning chime will sound when :

- the exterior lights are on
- the key is in the ignition switch

Warning and control indicator lights

The control indicators described are not present in all vehicles. The description applies to all instrument versions. Depending on the equipment, the position of the control indicators may vary.

When the ignition is switched on, most control indicators will illuminate briefly as a functionality test.

The control indicator colours mean:

red : danger, important reminder

yellow : warning, information, fault

green : confirmation of activation

blue : confirmation of activation

white : confirmation of activation











grey : system paused, at least one system limitation has been detected

































Overview





The numbers in the overview table indicate what to do, when a control indicator illuminates or flashes.

- 1 : only for information
- 2 : information and warning
- 3 : seek the assistance of a workshop
- 4 : stop engine and seek the assistance of a workshop
- 5 : have the cause of the fault remedied immediately by a workshop

6 : stop and leave the vehicle immediately and seek the assistance of a workshop

	1	Turn lights ⇔ page 76
	2	Seat belt reminder ⇔ page 76
	2	Seat occupied / unoccupied ⇔ page 76
	5	Airbag and belt tensioners ⇔ page 76
	2	Airbag activated
	2	Airbag deactivated ⇔ page 77
	4	Charging system ⇔ page 77
	5	Fault indicator light ⇔ page 77
	2	System check ⇔ page 78
	5	Malfunction electric engine
	5	Service vehicle soon ⇔ page 77

	4	Stop engine ⇒ page 77
	5	Hybrid system fault ⇒ page 78
	6	Brake and clutch system ⇒ page 78
	1/ 5	Parking brake ⇒ page 78
	5	Electric parking brake fault ⇒ page 78
	2	Automatic operation of electric parking brake off
	2	Anti-lock brake system (ABS) ⇒ page 78
	1	Descent control system
	4	Power steering ⇒ page 78
	2	Lane keep assist ⇒ page 78
	1	Lane departure warning ⇒ page 147
	1	Parking assist ⇒ page 79
	2	Parking assist off ⇒ page 79
	2/ 5	Electronic stability control and traction control system ⇒ page 79
	2	Electronic Stability Control and Traction Control system deactivated ⇒ page 79
	4	Engine coolant temperature high ⇒ page 79
	2/ 3	Deflation detection system ⇒ page 79
	4	Engine oil pressure ⇒ page 80
	2	Low fuel ⇒ page 80
	2	Charging cable connected ⇒ page 126
READY	1	Vehicle ready ⇒ page 80
	2	Reduced engine power ⇒ page 80
	2	High voltage battery level low ⇒ page 82
	6	High-voltage battery temperature high ⇒ page 80
	1	Apply footbrake
	1	Autostop ⇒ page 80
	1/ 3	Stop-start system deactivated
	1	Exterior light ⇒ page 80
	1	Low beam ⇒ page 81
	1	High beam ⇒ page 81
	1	High beam assist ⇒ page 81
	1	Rear fog light ⇒ page 46
	3	Pedestrian safety alert fault ⇒ page 81
	2/ 3	Active emergency braking ⇒ page 81

	2/ 3	Traffic sign assistant ⇒ page 81
	2/ 3	Driver alert ⇒ page 81
	2	Door open ⇒ page 82
	1	e-SAVE is activated ⇒ page 82

TURN LIGHTS

illuminates or flashes green.

Illuminates briefly

The parking lights are switched on.

Flashes

A turn light or the hazard warning flashers are activated.

Rapid flashing: failure of a turn light or associated fuse.

This includes turn lights connected to the socket of the towing equipment.

Bulb replacement ⇒ page 196.

Turn lights ⇒ page 46.

SEAT BELT REMINDER

 and  illuminate or flash.

The indicator lights within the symbol  indicate the respective seat.

1. Front left seat belt
2. Front right seat belt
3. Rear left seat belt
4. Rear centre seat belt
5. Rear right seat belt

Depending on the condition, the indicator lights may have different colours:





red : seat belt not fastened

green : seat belt fastened

grey : seat not occupied

- When the ignition is switched on and a seat belt is fastened the corresponding indicator light illuminates green. If one of the seat is detected as unoccupied, the corresponding indicator light illuminates grey.
- When the ignition is switched on and one of the front seat belts is not fastened,  and " illuminate with the respective indicator light in red (1 or 2).
- When the ignition is switched on and one of the rear seat belts is not fastened, " illuminates with the

respective indicator light in red (3, 4 or 5).

- After driving off,  and " and the corresponding indicator light flash red in the cluster for a certain time together with a chime if the respective seat is occupied but the seat belt is not fastened. After a certain time of driving,  and " illuminate constantly red until the seat belt of the respective seat has been fastened.
- If any passenger has unfastened the seat belt during driving,  and " flash red in the cluster for a certain time together with a chime. After a certain time of driving,  and " illuminate constantly red until the seat belt of the respective seat has been fastened again.

Seat belts ⇒ page 25.

AIRBAG AND BELT TENSIONERS

illuminates red.

When the ignition is switched on, the control indicator illuminates for approx. four seconds. If it does not illuminate, does not extinguish after four seconds or illuminates whilst driving, there is a fault in the airbag system.

Seek the assistance of a workshop.

The airbags and belt pretensioners may fail to trigger in the event of an accident.

Deployment of the belt pretensioners or airbags is indicated by continuous

illumination of .

Warning

Have the cause of the fault remedied immediately by a workshop.

AIRBAG DEACTIVATION



 illuminates yellow.

The front passenger airbag is activated.

 illuminates yellow.

The front passenger airbag is deactivated.

Airbag deactivation ⇨ page 30.

CHARGING SYSTEM

 illuminates red.

Illuminates when the ignition is switched on and extinguishes shortly after the engine starts.

Illuminates when the engine is running

Stop, switch off the engine. The vehicle battery is not charging. The engine cooling may be interrupted. The brake servo unit may cease to be effective. Seek the assistance of a workshop.

FAULT INDICATOR LIGHT

 illuminates or flashes yellow.

Illuminates or flashes yellow when the ignition is switched on and extinguishes shortly after the engine starts.

Illuminates when the engine is running

Fault in the emission control system. The permitted emission limits may be exceeded. Seek the assistance of a workshop immediately.

Flashes when the engine is running

The engine management system has a fault that could lead to catalytic converter damage. Ease up on the accelerator until the flashing stops. Seek the assistance of a workshop immediately.

SERVICE VEHICLE SOON

illuminates yellow.

Illuminates briefly when the ignition is switched on.

May illuminate together with other control indicators and a corresponding message on the cluster.

Seek the assistance of a workshop immediately.

STOP ENGINE

STOP illuminates red.

Illuminates briefly when the ignition is switched on.

Illuminates together with other control indicators, accompanied by a warning chime and a corresponding message on the cluster.

Stop the engine immediately and seek the assistance of a workshop.

SYSTEM CHECK

illuminates yellow or red.

Illuminates yellow

A minor engine fault has been detected.

Illuminates red

A major engine fault has been detected.

Stop engine as soon as possible and seek the assistance of a workshop.

HYBRID SYSTEM FAULT

illuminates red.

The hybrid system has a fault.

Switch off ignition and seek the assistance of a workshop.

BRAKE AND CLUTCH SYSTEM

When the symbol illuminates red the brake and clutch fluid level is too low, when parking brake is not applied.

 **Warning**

Stop. Do not continue your journey. Consult a workshop.

Illuminates when the manual parking brake is applied and the ignition is switched on ⇒ page 78.

PARKING BRAKE

illuminates or flashes red.

Illuminates

Parking brake is applied ⇒ page 112

Flashes

Electric parking brake is not applied automatically. The application or the release are faulty.

 **Warning**

Have the cause of the fault remedied immediately by a workshop.

ELECTRIC PARKING BRAKE FAULT

illuminates yellow.

Illuminates

Electric parking brake has a fault ⇒ page 112

 **Warning**

Have the cause of the fault remedied immediately by a workshop.

ANTI-LOCK BRAKE SYSTEM (ABS)

The symbol illuminates yellow for a few seconds after the ignition is switched on.

The system is ready for operation when the control indicator extinguishes.

If the control indicator does not extinguish after a few seconds, or if it illuminates while driving, there is a fault in the ABS. The brake system remains operational but without ABS regulation.

Anti-lock brake system ⇒ page 111.

GEAR SHIFTING**Manual mode**

▲ or ▼ with the number of a higher or lower gear is indicated, when upshifting or downshifting is recommended for reasons of fuel saving.

POWER STEERING

illuminates red or yellow.

The power steering has a fault. Drive carefully at a moderate speed and consult a workshop

LANE KEEPING ASSIST

illuminates or flashes yellow.

Illuminates

A fault has been detected.

Flashes

The system is correcting the unintended lane change.

Lane Keeping Assist ⇒ page 148

PARKING ASSIST



flashes yellow as soon as an obstacle gets closer to the vehicle.

Parking assist ⇒ page 155

illuminates yellow.

The system is deactivated.

Depending on version, may illuminate in green to indicate an automatic or semi-automatic parking manoeuvre.

ELECTRONIC STABILITY CONTROL AND ANTI-SLIP REGULATOR



illuminates or flashes yellow.

illuminates

The anti-slip regulator is selected off (snowy or icy conditions), or a fault in the system is present.

Continued driving is possible. Driving stability, however, may deteriorate

depending on road surface conditions. Have the cause of the fault remedied by a workshop.

After reconnecting the vehicle battery, (e.g. after maintenance work), is illuminated for several seconds. After this

time period, extinguishes. This is a normal procedure, the vehicle does not need any assistance.

Flashes

The system is actively engaged.

Engine output may be reduced and the vehicle may be braked automatically to a small degree.

Electronic Stability Control ⇒ page 145

Anti slip regulator ⇒ page 144

ENGINE COOLANT TEMPERATURE



illuminates red.

illuminates when the engine is running

Stop, switch off the engine.

Check coolant level immediately.

If there is sufficient coolant, consult a workshop.

EXHAUST FILTER



The symbol illuminates yellow when the exhaust filter requires cleaning.

Continue driving until the control indicator extinguishes.

illuminates temporarily

Start of saturation of the exhaust filter.

Start cleaning process as soon as possible by driving at a vehicle speed of at least 40 mph.

TYRE DEFLATION DETECTION SYSTEM



illuminates or flashes yellow.

illuminates

Tyre pressure loss in one or more wheels. Stop immediately and check the tyre pressure.

Flashes

Fault in the system. Consult a workshop.

Tyre deflation detection system ⇒ page 171

ENGINE OIL PRESSURE



illuminates red when the ignition is switched on and extinguishes shortly after the engine starts.

Illuminates when the engine is running

CAUTION

Engine lubrication may be interrupted. This may result in damage to the engine and / or locking of the drive wheels.

1. Select neutral gear.
2. Move out of the flow of traffic as quickly as possible without impeding other vehicles.
3. Switch off the ignition.

Warning

When the engine is off, considerably more force is needed to brake and steer.

During an Autostop, the brake servo unit will still be operational.

Do not remove key until vehicle is stationary, otherwise the steering wheel lock could engage unexpectedly.

Keep engine turned off and let the vehicle be towed to a workshop.

LOW FUEL



illuminates yellow.

Level in fuel tank is too low.

VEHICLE READY

READY illuminates green. The hybrid system is active.

REDUCED ENGINE POWER



illuminates yellow.

The charging level of the high-voltage battery is low. Only reduced engine power is available.

HIGH-VOLTAGE BATTERY TEMPERATURE HIGH



illuminates red.

Illuminates briefly when the ignition is switched on.

Illuminates together with other control indicators, accompanied by a warning chime and a corresponding message in the cluster.

Stop engine immediately and evacuate the vehicle.

AUTOSTOP



Illuminates briefly when the ignition is switched on.

Illuminates together with other control indicators, accompanied by a warning chime and a corresponding message in the cluster.

Stop engine immediately and evacuate the vehicle.

EXTERIOR LIGHT



illuminates green.

The exterior lights are on ⇨ page 44.

LOW BEAM

 illuminates green.

Illuminated when low beam is on.

HIGH BEAM

 illuminates blue.

Illuminated when high beam is on or during headlight flash ⇒ page 44.

HIGH BEAM ASSIST

 illuminates green.

The high beam assist is activated.

REAR FOG LIGHT

 illuminates yellow.

The rear fog light is on ⇒ page 46.

RAIN SENSOR

 illuminates green.

Illuminates when rain sensor position on wiper lever is selected.

Windscreen wiper and washer ⇒ page 42

PEDESTRIAN SAFETY ALERT FAULT

 illuminates yellow.

The pedestrian safety alert is not working.

ACTIVE EMERGENCY BRAKING

 illuminates or flashes yellow.

Illuminates

The system has been deactivated or a fault has been detected.

Additionally, a warning message is displayed in the cluster.

Check the reason of the deactivation and in case of a system fault, seek the assistance of a workshop.

Note

 also illuminates if the seat belts of the front passengers are not fastened. In this case, active emergency braking is deactivated.

Flashes

The system is actively engaged.

Depending on the situation, the vehicle may automatically brake moderately or hard.

Active emergency braking ⇒ page 137

TRAFFIC SIGN ASSISTANT

 illuminates for a few seconds or permanently.

Illuminates for a few seconds

If the vehicle exceeds the speed limit provided by the traffic sign assistant, the speed limit displayed in the cluster flashes and an audible signal is given. If flashing and audible signal are

deactivated,  illuminates for a few seconds.

Illuminates permanently

If the traffic sign assistant has a failure,  illuminates permanently.

Stop the vehicle and check, if the camera needs to be cleaned. If  still illuminates after cleaning the camera, consult a workshop

Traffic sign assistant ⇒ page 172

DRIVER DROWSINESS DETECTION

 illuminates yellow.

The driver drowsiness detection is deactivated.

Driver Drowsiness Detection (DDD) ⇒
page 163

DOOR OPEN



illuminates red.

A door or the tailgate is open.

E-SAVE FUNCTION



illuminates blue.

The e-SAVE function is activated.

Depending on the situation, the function allows electricity to be stored for use when needed (e.g. passing through an urban area or an area reserved for electric vehicles).

Infotainment

- First steps..... 83
- Personalisation..... 88
 - Pure Mode..... 89
- 10 steering-mounted controls..... 89
- Applications..... 90
 - Passenger side apps..... 91
- Voice commands..... 91
- Navigation..... 93
 - EV Routing..... 94
- Connectivity..... 95
- Mirror Screen®..... 97
- Media..... 99
- Phone..... 102
- Settings..... 104
- User Manual..... 105

First steps

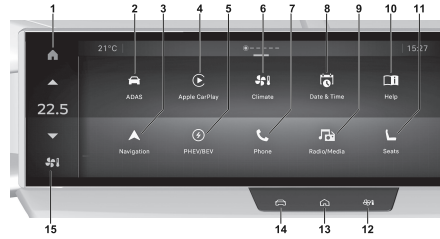

 The system starts when the ignition is switched on.

- Short press, ignition off: system on/off.
- Short press, ignition on: mute/restore sound.
- Long press, ignition on: start standby mode (mute sound and clock display).

- Rotate collar: Adjust volume

App wall overview (depending on version):

1	Home page
2	Advanced Driver Assistance Systems (ADAS) menu
3	Navigation system

4	Apple CarPlay®
5	Energy
6	Climate control
7	Phone
8	Date and time
9	Radio and media
10	Help
11	Seats
12	Climate control shortcut
13	Home page shortcut
14	ADAS shortcut
15	Climate control

Information

This system gives access to the following elements:

- Audio equipment and telephone controls with display of associated information.
- Connected services and display of associated information.
- Navigation system controls and display of associated information (depending on equipment).

- Voice recognition (depending on equipment).
- Time and outside temperature.
- Heating/air conditioning system controls and reminders of settings.
- Settings for driving aid functions, comfort and safety functions, extended head-up display (depending on equipment and version), audio equipment and digital instrument panel.
- Settings for functions specific to rechargeable hybrid vehicles.
- Settings for functions specific to electric vehicles.
- Display of visual manoeuvring aid functions.
- Video tutorials by QR code (e.g. screen management, driving aids, voice recognition).

Upper banner

Certain information is displayed permanently in the upper banner of the touchscreen:

- Outside temperature from the vehicle's sensors (associated with a blue symbol if there is a risk of ice).

- Temperature setting reminder for the air conditioning on the driver's and passenger sides.
- Charge level of the connected smartphone.
- System connection status (Bluetooth®, Wi-Fi, mobile telephone network).
- Time.
- Quick access to the Mirror Screen® functions (associated with a connected smartphone).

Swipe down from the upper edge of the touchscreen to access the notifications centre and display a list of quick settings: Guest, Privacy Settings, Brightness, My Devices, night mode, etc.

Principles



- Use this button (HOME) to display the most recent home page used; a second press displays the first home page, then press the virtual buttons displayed on the touchscreen.



Scroll through the home pages by sliding your finger along the screen to the right or to the left.

Principle of movement in the system
Depending on the pages displayed on the screen, scroll through the text or the menu (on the left side of the screen) by sliding your finger, as with a smartphone.

Touch buttons



Display/hide the context menu.



Return to the previous page.

- To change the status of a function, press the description for the corresponding line (change confirmed by the slider moving to the right/left: function activated/deactivated).



Access to additional information about the function.



Access to a function's settings.



Add/delete shortcuts.

Physical buttons

Below the infotainment screen are some physical buttons that let the driver access various functions without navigating to them on the screen.



Short press: Opens the home page

Long press: Opens the Screen Mirroring app.



Short press: Opens the ADAS page

Long press: Deactivates all ADAS set by the driver as favourite.



Short press: Opens the climate control page.

Configuring profiles



Press the **"Settings"** application.

In the list, select the **"Profile"** tab.

The screen displays a "Guest" profile built into the system and allows you to create and personalise several new

profiles with or without an associated mobile device.



The **"Guest"** profile has a default display with the possibility of adding to it and/or returning it to its initial configuration. This profile is built into the system and cannot be deleted.



Each profile created can be associated with a mobile device of your choice connected via Bluetooth®; the Bluetooth® function of the mobile device must first be activated.

The last profile used will be highlighted at each starting.



Select **"Create Profile"**, then follow the procedure.

The advantage of creating a new profile is to personalise:

- Language, units, privacy settings.
- Screen configuration, appearance, i-Toggles (depending on equipment).
- Audio settings, favourite radio stations.
- Lighting, interior ambience (refer to the "Ease of use and comfort" section).

- Navigation history, favourite points of interest (POIs), navigation settings.
- Some driving aids and the list of favourites.



To delete a profile, select it from the list of profiles then press the bin.

Privacy Settings

The "Privacy Settings" management is associated with each profile. This function is used with: a "Guest" profile configured by default in "Private Mode", or a profile to be created in the system, with or without connection to a mobile device.

For each profile (even "Guest"), the last privacy mode saved value will be restored.

"Sharing Data and Location"



This mode allows the vehicle to externally transmit all the personal data needed for each valid available connected service.

Note

The personal data required to use the connected services is sent to the providers of these services.

"Sharing Data"

This mode allows the vehicle to externally transmit all the data needed for each valid available connected service, with the exception of vehicle location data (e.g. GPS coordinates).

Note

Some connected services may not function without the vehicle location data.

Note

This mode will not be applied to the emergency call function or to specific services to which the user has consented under the terms of commercial contracts (e.g. connected alarm).

"Private Mode"

This mode does not allow the vehicle to transmit personal data outside the vehicle.

Note

Connected services will only perform local processing inside the vehicle with limited functions.

Note

This mode will not be applied to the emergency call function or to specific services to which the user has consented under the terms of commercial contracts (e.g. connected alarm).

Note**Professional purposes**

If the vehicle is used for professional purposes or under the terms of specific contracts (e.g. corporate fleet, government assignment), some privacy modes will not be available for the user on the screen, depending on the data sharing needs of the services.

To change mode, swipe down from the upper edge of the touchscreen to display all of the quick settings.



Press this button and select the chosen mode. The mode is highlighted.

OR



Press the **"Settings"** application.

In the list, select the **"Connectivity"** tab.



Select **"Privacy Settings"**.



Choose the mode.

AppMarket**Subscription**

Using a computer or smartphone, create or open a **MyVauxhall** account on the Brand's website.

Go to the subscription section of the AppMarket.

Select the country of residence.

Select the desired mode:

- **"Intermediate"**: free, with additional features and accessible with authentication.
- **"Premium"**: paid, with full features and accessible with authentication.

After subscription, user can access to a third mode:

- **"Discovery"**: free and accessible without authentication.

Authentication

When the vehicle is started, the touchscreen is switched on and the user has subscribed to one of the AppMarket modes, the **"AppMarket"** icon appears on the applications wall.

The authentication process is automatic, when the user has previously associated his smartphone and their **MyVauxhall**

account to their profile, and the smartphone is detected in the vehicle.

The connected mobile device serves as an access key to the **"Intermediate"** and/ or **"Premium"** AppMarket mode and profile applications. First activate the mobile device's Bluetooth® function.



Press the **"AppMarket"** icon to install new applications or update applications already installed.

In case of smartphone detection problems, use the manual authentication procedure:



Press the **"AppMarket"** icon. The manual authentication page is displayed.

Enter the email address and password of the **MyVauxhall** account.

Press the **"Validate"** button.

The profile application icons are available on the applications wall.

Note

In case of an authentication problem, the following message appears: **"You are not authenticated, your 10 connected services won't be accessible"**.

The profile application icons are then inactive and greyed out.

Repeat the procedure. If the problem persists, contact a dealer.



With the use of the **"Guest"** profile, only the **"Discovery"** mode is accessible.

Updating the system

Managing devices remotely and remote updating of software and firmware.

Note

Being an integral part of the service used to provide connected services contracts(s), the required management of devices as well as the required updating of the software and firmware associated with the aforementioned connected service will be carried out remotely, in particular using "Over the Air" technology.

To do this, a secure connection via radio network is established between the vehicle and the Manufacturer's device management server each time the ignition is switched on, when a mobile telephone network is available.

Depending on the vehicle's equipment, the connection configuration must be set

to "Connected vehicle" to enable the connection to the radio network.

Irrespective of a valid subscription to a connected service, the remote management of devices relating to or connected with the security of devices, and the updating of software and firmware, will be carried out when necessary in order to comply with a legal requirement applicable to the Manufacturer (e.g. the applicable law in terms of product liability, the regulations governing e-call) or when necessary to protect the respective vital interests of the vehicle's users and passengers.

The establishment of a secure connection via radio network and the corresponding remote updates are not affected by the privacy settings and are intended to be carried out after being initialised by the user in response to a related notification.

The system can notify the receipt of an update when it is connected to an exterior Wi-Fi network or a mobile telephone network.

Large updates are downloaded only via the Wi-Fi network.

The availability of an update is notified on the screen at the end of the journey

with an option of immediate installation or postponement of installation.

The installation time is variable and can take several minutes, or up to a maximum time of about 30 minutes. A notification will give an estimate of the duration and a description of the update.

Update information is available through the "Settings" application.



Press the **"Settings"** application.

In the list, select the **"Updates"** tab.



This button allows you to change the authorisation for automatic downloading of updates via an exterior Wi-Fi network.

Warning

For safety reasons and because it requires sustained attention on the part of the driver, the installation must be carried out with the ignition on but without starting the engine.

The installation cannot be carried out in the following cases:

- engine running.
- emergency call in progress.
- insufficient battery level.
- when charging for electric vehicles.

If an update has failed or has expired, contact a dealer or a qualified workshop.

Warning

The manufacturer does not charge for the use of this service.

However, the use of Wi-Fi and/or mobile phone networks by your smartphone may incur extra charges if you exceed the data allowance included in your contract.

Any associated costs will be billed to you by your mobile telephone operator.

Personalisation



Press and hold the screen from one of the system's home pages.

Or



Press the **"Settings"** application.

In the list, select the **"Customisation"** tab.

Press the **"Displays"** field.

A page divided into 2 parts is displayed.

Press the HOME button at any time to leave this page.

Personalising the screen



Press the pencil in the **"Customise Touchscreen"** part.

A representation of the organisation of the different home page (**HOME**) Widgets is displayed.

Note

A widget is a reduced window of an application or service.

Adding a Widget



To add a Widget, press "**Widget**" on the left of the screen.

Or



Press one of these buttons on the screen.

Select the desired Widget.



Press the back arrow to return to the previous page.

Organising the Widgets on a home page (HOME)

To move a Widget, press and hold it, then drag it to the desired location.

Adding a page



To add a page, press "**Page**" on the left of the screen.



Press the back arrow to return to the previous page.

Deleting a Widget



To move a Widget to the bin, press and hold it, then drag it to the bin.

Personalising the instrument panel



Press the pencil in the "**Customise Driver Information**" part.

The modification of the organisation of the different Widget is displayed on the instrument panel in real time.

Note

A widget is a reduced window of an application or service.

Adding a Widget



To add a Widget, press "**Widget**" on the left of the screen.

Or



Press one of these buttons on the screen.

Select the desired Widget.



Press the back arrow to return to the previous page.

Deleting a Widget



To move a Widget to the bin, press and hold it, then drag it to the bin.

PURE MODE

Depending on version, on the left of the customisable pages is a special page with a fixed layout designed to reduce distractions to the driver in certain driving conditions.

Pure Mode ⇒ page 69

10 steering-mounted controls

Voice control:



Short press, system voice commands (depending on equipment).

Long press, voice commands of the smartphone connected using Bluetooth®

or Mirror Screen® (Apple® CarPlay®/Android Auto) via the system.

 Increase volume.

 Decrease volume.

Mute the sound: long-press on the decrease volume button.

Restore the sound by pressing one of the two volume buttons.



Incoming call (short press): accept the call.

Call in progress (short press): hang up.

Incoming call (long press): refuse the incoming call.

Out of call (short press): access the call log of the telephone connected via Bluetooth®.

Mirror Screen® connected (short press): access the projected view of the telephone application of your Mirror Screen® equipment.

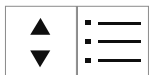

Radio: automatic search for the previous/next station (in the list

of radio stations sorted by name or by frequency).

Media: previous/next track, movement in lists.

Phone: browse the telephone's call log.

Short press: validate a selection. Out of selection, display lists.

Applications



From the home page, press this button to access the applications wall.

Note

From any page, press the touchscreen with three or more fingers to display the applications wall.

Help



Access the handbook and watch tutorials.

Radio/Media



Select an audio source or radio station.

Mirror Screen®



Smartphone connected with Mirror Screen®: access to the projected view of Apple® CarPlay® or Android Auto.

Smartphone not connected: access the menu allowing you to connect a smartphone.

Navigation



(depending on equipment) Enter navigation settings and choose a destination.

Use services available in real time, depending on equipment.

Voice commands



(depending on equipment) Use the system or smartphone voice recognition via the system.

Phone



Telephone not connected: access the menu allowing you to connect a telephone.

Telephone connected: access the call log, contacts and telephone settings.

Two connected telephones: access the contents of the priority telephone with the possibility of changing the priority of the telephone.

Date/Time



Settings for the date and time of the audio system.

Settings



Main settings for the audio system, touchscreen and digital instrument panel.

PASSENGER SIDE APPS

Depending on version, the infotainment system features a section designed to be used by the front passenger.

It features a climate control dock and space for a widget. Scroll through the widgets by sliding your finger along the screen up or down.

Voice commands

First steps

(depending on equipment)

The voice recognition service offers a choice of several languages (e.g. French, German, English (UK), English (US), Arabic, Brazilian, Canadian, Chinese, Danish, Spanish, Hebrew, Italian, Japanese, Korean, Mexican, Dutch, Norwegian, Polish, Portuguese, Russian, Swedish, Czech, Turkish) available with the mobile network and in line with the language chosen and previously configured in the system.

Information - Using the system



When voice commands are activated, say your command after the audible signal.

For commands in several stages, interaction takes place with the system to complete the initial request.

Some commands self-validate after 7 seconds.

If the system has not taken your command into account, it will indicate this by a voice message and an on-screen display.



Press the **"Settings"** application.

In the list, select the **"Voice Assistant"** tab.



Activate/Deactivate:

- **"Listen for (Hey Vauxhall)":** to invoke the voice recognition using the keyword **"Hey Vauxhall"**.
- **"Vocal Barge-In":** to allow user to speak over spoken dialogue prompts and be recognised.
- **"Data Usage":** to authorise our supplier to re-use your data so that they can globally improve the vehicle's capabilities in terms of voice recognition and voice assistance.

Note

Voice assistant/data usage

Vehicle's location and voice recordings are not concerned; only textual transcriptions of your conversations with the voice assistant are kept after being pseudonymised.

Opening voice recognition



Voice commands can be used on any screen page, provided there are no other sources which take priority in use (reverse, emergency or assistance call, telephone call, other smartphone voice recognition already launched).

Choice of opening voice recognition:

- Say **"Hey Vauxhall"**.

or

- Press the button located on the steering wheel.

or

- Press the touchscreen button.

Warning

To ensure that voice commands are always recognised by the system, please follow these recommendations:

- **Use natural language in a normal tone without breaking up words or raising your voice.**
- After opening voice recognition with the steering wheel-mounted button or the button on the touchscreen, always wait for the "beep" (audible signal) before talking. No "beep" sounds when voice recognition is opened using "Hey Vauxhall".
- For optimal operation, it is recommended that you close the windows and the sunroof (depending on equipment) to avoid any external interference, and switch the ventilation off.
- Before speaking the voice commands, ask the other passengers not to speak.



Voice command example for air conditioning:

"Increase the fan speed"

"Turn on air conditioning"

"I'm too hot"



Voice command example for radio and media:

"I want to listen to Michael Jackson"

"Switch to radio"

"Tune to 88.5"



Voice command example for navigation:

"Navigate home"

"Navigate me to Gabrielle's house"

"Search for public parking nearby"

Note

Depending on the country, give destination (address) instructions in the language configured for the system.



Voice command example for telephone:

"Call Matthew's mobile"

"Call 0113 345 9869"

"Call Jonathan"

Note

If there is no telephone connected by Bluetooth®, a pop-up appears:

"Connect a telephone by Bluetooth®", and the voice session will be closed.

ChatGPT

Chat GPT is part of the Connected Services and if the user subscribes to it, it will enable an extended range of functions.

Navigation

Navigation home screen

(depending on equipment)

Press the **"Navigation"** application to display the navigation home screen.



Press **"Search"** to enter an address or a name.



Press this button to display the main menu for the various options.



Press this button to display the 3D/2D mode.



Select **"Sound activated"**, **"Alerts only"** and **"Silent"** with successive presses on this button.



Press the "plus"/"minus" buttons to zoom in/out, or use two fingers on the screen.

Main menu



Press the **"Navigation"** application to display the navigation home screen.



Press this button to display the main menu for the various options.



Select **"Search"** to enter an address, name or some points of interest.



Select **"Go home"** using an address previously saved in **"Add home"**.



Select **"Go to work"** using an address previously saved in **"My places"**.



Select **"Recent destinations"** to display the latest destinations searched.



Select **"Current trip"** to open another menu and perform various actions for the current planned route.



Select **"My places"** for quick access to saved places as well as favourite destinations.



Select **"My trips"** to display your favourite routes.



Select **"Parking"** to display the various parking options in the area.



Select **"Service station"** to display the different service stations on the current route or near the current location.



Select **"TomTom service"** to check the network status.



Select "**Settings**" to enter the vehicle type and to personalise the display, voice instructions, map options, trip planning, sounds and alerts, and system information.



Select this button to display details on software versions as well as legal information. Details of the Open Source software libraries used and their licence URLs.

Note

Regular connection to a secure Wi-Fi access point automatically updates the installed mapping globally.

The mapping is also updated using a mobile network, depending on version, country of sale, the vehicle's level of equipment, as well as the subscription to connected services and options.

However, using your smartphone's Wi-Fi and/or mobile networks may incur additional charges if you exceed your data plan.

These charges, if any, will be passed on to your telephone operator's bill.

EV ROUTING

Note

EV Routing is part of the Connected Services if the user subscribes to it.

On BEV vehicles, the navigation system incorporates several features designed to guide drivers through efficient and worry-free journeys.

The system will adapt the routing of journeys to minimise travel duration, maximise EV efficiency and vehicle range and provide real-time information on charging points to help drivers find somewhere to charge along their journey.

The system will try to find the optimum route, preferring the most powerful charging stations to reduce the number of stops, and trying to maximise driving speed. If the journey cannot be completed with the current level of charge, the EV navigation will automatically add charging stops.

EV navigation shows the details of the charging station, the estimated time of arrival at the station, the estimated charge time, and the estimated time of arrival at the final destination.

The driver can select the preferred charge point provider to adapt the routes accordingly. The EV navigation

system will automatically adapt if the conditions change (availability, detour) and continuously update the route to keep the next charging stop within range, and notifies the driver in case of recalculation.

At the end of a trip, the distance, trip duration, average energy consumption and remaining range will be displayed.

Navigation settings

Open the **Navigation settings** page.

On the **Map & Display page**, the **Range visualisation**, which shows the remaining range on the map can be enabled/disabled.

On the **Planning & Travel page**, the desired level of charge when arriving at a charger and the desired state of charge when arriving at a destination can be set.

On the **Vehicle Setting page**, the charging station's socket can be selected, depending on the cable present onboard.

e-Routes by Free2Move Charge

e-Routes by Free2Move Charge is a powerful travel planner smartphone application. It is designed to guide the

driver and optimise trips using real-time vehicle data, suggesting the best routes based on the state of the charging stations along the way.

e-Routes is compatible with Android Auto and Apple®CarPlay®, and can be used from the vehicle's touchscreen.

Connectivity

Connecting a wired device by USB

The USB connection of a mobile device allows it to be recharged. It makes its authorised media content available to the system (Media content of iPod® type).



Only one USB socket will allow a Mirror Screen connection (Apple® CarPlay® or Android Auto) for the compatible connected mobile devices and to use some of the device's applications on the touchscreen.

For more information on the USB socket compatible with the Mirror Screen® function, refer to the "Ease of use and comfort - Fittings" section.

The mobile device is in charging mode when connected with the USB cable.

Tip

It is recommended that you use your device's original USB cables, preferably with a short cable to ensure optimum performance.

Warning

To protect the system, do not use a USB hub.

Bluetooth® connection

Connecting a mobile device to the vehicle's system via Bluetooth® provides access to its contents and its "Media" streaming. It also enables the Phone function to be activated.

The connection can be initiated either from the mobile device's Bluetooth® menu or from the vehicle's system, which requires opening the "My Devices" menu for the first connection.

Note

In some cases, you will need to unlock your device and check the authorisation to synchronise contacts and recent calls.

Some features may not be supported by your device.

For information on the partial or full compatibility of device models or smartphones, please connect to the Brand's national website.

Pairing procedure from a device



From the Bluetooth® menu on your mobile device, select the system's name from the list of detected devices.

Note

In order to make your system's Bluetooth® visible, first open the "My Devices" menu on the system.

Continue the first connection procedure proposed by the system and on the device.

For example: validating pairing codes.

Pairing procedure from the system



Press the "Settings" application.

In the list, select the "Connectivity" tab.



Select **"My Devices"**.



Select the name of the mobile device that you want to connect, from:

– The list of known devices (if the device has already been connected to the system).

or

– The list of detected devices (if the device has never been connected to the system or previously deleted from the system).

Note

A mobile device already connected to the system will be able to reconnect automatically when the vehicle is started, once the user profile has been selected.

Automatic reconnection is put on hold as soon as the "My Devices" menu is opened.

This is to allow the system to make its Bluetooth® visible for the connection of a new device.

The system is disconnected when the driver's door is opened and the ignition is switched off.

Automatic reconnection

The system allows automatic reconnection of devices already connected and detected when a user profile is selected.

The priority reconnected devices are those which have been linked to the selected user profile or, failing this, the last connected devices.

Wi-Fi connection

The system has an external Wi-Fi connection mode for performing system updates.



Press the **"Settings"** application.

In the list, select the **"Connectivity"** tab.



Select **"Wi-Fi"**.



Activate/Deactivate **"Wi-Fi"**.

The system starts a search for nearby Wi-Fi networks. This may take a few seconds.

Select the Wi-Fi network to connect to and enter its password.

Warning

To protect your system, only networks with a sufficient level of security are allowed to connect. WPA2 encryption level, equivalent to a domestic level, is required.

Note

Any network already connected to the system will reconnect automatically as soon as it is detected by the system and after having previously activated the Wi-Fi function.

Note

The Wi-Fi connection of the system to a device already connected using a Mirror Screen® wireless connection is not possible.

In this case, favour a Mirror Screen® connection using the USB socket.

Device management

For each device already connected to the system using a wireless connection (Bluetooth® or wireless Mirror Screen® connection), it is possible to determine a preferred connection mode (depending on the functions the device can support). It is therefore possible to determine whether the device should be connected using a wireless Bluetooth® connection or a wireless Mirror Screen® connection each time the system is started once the profile is chosen.



Press the **"Settings"** application.

In the list, select the **"Connectivity"** tab.



Select **"My Devices"** to display the list of paired devices.



Press this button to manage the connection of a device.

Choose a connection type then confirm this choice by pressing **"APPLY"**.

Deleting a device



Press the **"Settings"** application.

In the list, select the **"Connectivity"** tab.



Select **"My Devices"** to display the list of paired devices.



Press this button.

Press **"DELETE"**.

Confirm by pressing **"YES"**.

⚠ Warning

Some devices that have just been deleted from the system request a connection, refuse this request.

Mirror Screen®

Note

When a smartphone is connected using Mirror Screen®, the vehicle's location and some vehicle data is sent to the smartphone (e.g. Brand, left-hand or right-hand drive, day/night mode, physical speed).

Apple® CarPlay® smartphone connection

Connecting just one Apple® CarPlay® smartphone can be carried out either by USB cable or using a wireless connection.

Note

First activate the Siri® function on your Apple® smartphone.

If the device fails to connect, refer to the Apple website to check that the device is compatible with this function.

If the problem persists, delete all saved connections on the smartphone and on the system before attempting a new connection.

The cable connection requires that you deactivate the CarPlay function in the **Settings, Bluetooth** menu of your smartphone.

In the **Bluetooth** menu, tap the "i" next to the relevant vehicle and deactivate CarPlay.



Connect the smartphone to the system using the USB socket compatible with Mirror Screen.

Apple® CarPlay® automatically launches a few seconds after the USB connection

is established. In some cases, it may be necessary to unlock your device.

The smartphone charges when connected by the USB cable.

The cable connection allows you to avoid disconnections, especially when passing through toll booths.

Note

Only one USB socket enables the Mirror Screen® connection (Apple® CarPlay®); refer to the "Dashboard instruments and control - USB Port" section.

It is recommended that you use the device's original USB cables, preferably with a short cable to ensure optimum performance.

The wireless connection of an Apple® CarPlay® smartphone can be initiated from the "**My Devices**" menu.

First activate the smartphone's CarPlay® function.

In the **Bluetooth** menu, tap the "i" next to the relevant vehicle and activate CarPlay.



Press the "**Settings**" application.

In the list, select the "**Connectivity**".



Select "**My Devices**" to display the device to be connected to Apple® CarPlay®.

If the device has already been connected to the system via Bluetooth®, select the device settings from the list of known devices and choose Apple® CarPlay® as the wireless connection mode.

If the device has never been connected to the system before, it will have to be paired (refer to the "Bluetooth® connection" section).

The system detects if the smartphone is compatible with Apple® CarPlay® and offers to connect to it following the pairing process.

Subsequent automatic connection of the smartphone requires activation of the Bluetooth® on your device.



As soon as the connection is established, press this button to display the "**Apple® CarPlay®**" interface.



To initiate the smartphone voice commands, press and hold the steering-mounted control button.

Android Auto smartphone connection

Connecting just one Android Auto smartphone can be carried out either by USB cable or using a wireless connection.

Note

First install the "**Android Auto**" application via "Play Store" on your smartphone.

The "**Android Auto**" function requires a compatible smartphone.

If the device fails to connect, refer to the Android Auto website to check that the device is compatible with this function.

If the problem persists, delete all saved connections on the smartphone and on the system before attempting a new connection.

To ensure an optimum wireless connection, we recommend not placing your smartphone too close to other Wi-Fi networks to which it can connect automatically.

The cable connection requires that you deactivate the Android Auto wireless function, in the **Settings** menu of the **"Android Auto"** application of your smartphone.



Connect the smartphone to the system using the USB socket compatible with Mirror Screen®.

Android Auto automatically launches a few seconds after the USB connection is established. A validation procedure on the smartphone has to be followed for the first connection, with the vehicle stationary.

The smartphone charges when connected by the USB cable.

The cable connection allows you to avoid disconnections, especially when passing through toll booths.

Note

Only one USB socket enables the Mirror Screen® connection (Apple® CarPlay®); refer to the "Dashboard instruments and control - USB Port" section.

It is recommended that you use the device's original USB cables, preferably with a short cable to ensure optimum performance.

The wireless connection of an Android Auto smartphone can be initiated from the **"My Devices"** menu.

First activate the smartphone's Android Auto® wireless function, in the **Settings** menu of the **"Android Auto"** application of your smartphone.



Press the **"Settings"** application.

In the list, select the **"Connectivity"**.



Select **"My Devices"** to display the device to be connected to Android Auto.

If the device has never been connected to the system before, it will have to be paired (refer to the "Bluetooth® connection" section).

The system detects if the smartphone is compatible with Android Auto and offers to connect to it following the pairing process.

If the device has already been connected to the system via Bluetooth®, select the device settings from the list of known devices and choose Android Auto as the wireless connection mode.

The subsequent automatic connection of the smartphone requires activation of Bluetooth® on your device.



As soon as the connection is established, press this button to display the **"Android Auto"** interface.



To initiate the smartphone voice commands, press and hold the steering-mounted control button.

Media

Changing source



Press the **"Media"** application.



Press this button to change source (radio, audio streaming via a USB socket, Bluetooth® or Mirror Screen®).

Selecting a radio station



Press the **"Media"** application.
In the list, select the **"Player"** tab.

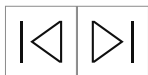

Press one of the buttons to perform an automatic search for radio stations.

Or



Move the slider to manually search for frequencies up or down.

Or



Press this button.



Enter the frequency values using the virtual keypad.



Press this button to confirm.

A list of stations is available by pressing the **"Stations"** tab.



Press **"Mute"** to activate/deactivate the sound.

Warning

Radio reception may be affected by the use of electrical equipment not approved by the manufacturer, such as a charger with USB socket connected to the 12 V socket.

The exterior environment (hills, buildings, tunnels, basement car parks, etc.) may block reception, including in RDS mode. This phenomenon is normal in the propagation of radio waves and does not indicate any malfunction of the system.

Storing a radio station

Select a station.



Press the **"Media"** application.
In the list, select the **"Player"** tab.



Press the **"Radio Favourites"** button.



Storing takes place via a short or long press on one of these buttons, or a long press on an existing favourite radio station, which will be replaced.



Press this button to return to the previous page.

Automatic search for radio stations

Via the **"Media"** application.



Press the **"Media"** application.
In the list, select the **"Stations"** tab.

The search is carried out automatically.



Using the steering-mounted controls, press and hold this button.

The search is carried out automatically.

Activating radio station tracking

The system changes frequency automatically to obtain better reception.



Press the **"Media"** application.
In the list, select the **"Settings"** tab.



Activate **"Radio Station Tracking"**.

The lighting of the slider confirms that the function is activated.

Changing the waveband



Press the **"Media"** application.
In the list, select the **"Settings"** tab.



Press this button to change the waveband (FM - AM - DAB) according to the country of sale.

Activating traffic announcements

This function gives priority to listening to **Traffic announcements** alert messages.

To be active, this function needs good reception of a radio station that transmits this type of message.

While traffic information is being broadcast, the current radio station is automatically interrupted so that the message can be heard. Normal radio listening resumes as soon as the message is finished.



Press the **"Media"** application.
In the list, select the **"Player"** tab.



Activate **"Traffic Announcement (TA)"**.

The lighting of the slider confirms that the function is activated.

Audio streaming

The streaming function allows you to listen to the audio stream coming from the smartphone(s) connected via Bluetooth®, USB (iPod® type) or Mirror Screen®.

First adjust the volume on the portable device (to a high level).

Then adjust the volume of the system.

If playback does not start, it may be necessary to start the audio playback from the smartphone.

Control is from the portable device or by using the system's touch buttons.

Note

Once connected in streaming mode, the smartphone is considered to be a media source.

Playing a track



Press the **"Media"** application.



If several devices are connected, press this button to select one.

Once the device is connected, browsing through the files is possible by pressing the **"Playlist"** or **"Library"** button.

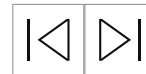

Short press: go to the previous/ next track.

Long press: fast-forward/rewind in a track.



Repeat the current title or the list of selected titles.



Random track playback.



Sound deactivation/reactivation.

Configuring audio and radio settings

Audio settings can be accessed in 2 different ways.

Via the **Media** application



Press the **"Media"** application.
In the list, select the **"Settings"** tab.

Or Via the **Settings** application



Press the **"Settings"** application.
In the list, select the **"Audio and Radio"** tab.

It is possible to configure:

- sound settings.
- radio settings.
- volume settings.

Information and advice

The system supports USB mass storage devices or Apple® devices via the USB sockets. The adapter cable is not supplied.

Devices are managed using the audio system controls.

The system will only play audio files with ".wma, .aac, .flac, .ogg, .mp3" file extensions, at bit rates between 32 Kbps and 320 Kbps.

It also supports VBR (Variable Bit Rate) mode.

No other file types (".mp4", etc.) can be read.

".wma" files must be of the WMA 9 standard.

The supported sampling rates are 32, 44 and 48 KHz.

To avoid reading and display problems, we recommend choosing file names less than 20 characters long that do not contain any special characters (e.g. " ? . ; ù).

Use only USB memory sticks in FAT32 (File Allocation Table) format.

Note

We recommend using the original USB cable for the portable device.

Phone

Receiving a call

An incoming call is announced by a ring and a display overlaid on the screen.

Accepting the call:



briefly press the telephone button on the steering-mounted controls to accept an incoming call.

Or



Press this touchscreen button.

Ending the call:



press and hold...



the telephone button on the steering-mounted controls to refuse the call.

Or



Press this touchscreen button.



Press this button on the touchscreen to send an automatic message indicating that you are driving.

Making a call

Warning

Using your phone is strongly discouraged while driving.

Park the vehicle.

Making a call using the numeric keypad



Press the **"Phone"** application.

In the list, select the **"Keypad"** tab, then dial the number.



Press this button to make the call.

Making a call using the list of recent calls



Press the **"Phone"** application.

In the list, select the **"Calls"** tab.

Or

Briefly press...



the telephone button on the steering-mounted controls.

Select and call one of the most recent numbers called in the list.

Note

It is always possible to make a call directly from the telephone; as a safety measure, first park the vehicle.

Calling a contact



Press the **"Phone"** application.

In the list, select the **"Contacts"** tab.

Select the desired contact in the displayed list.



Call the contact by selecting one of the contact's phone numbers.

Organising the contact list



Press the **"Phone"** application.

In the list, select the **"Settings"** tab to display the telephone-related settings.



Choose to list the contacts starting with their first or last name.

Connecting two phones

Note

The system allows two phones to be connected simultaneously:

- 2 via Bluetooth® connection

or

- 1 via Bluetooth® connection and 1 via Mirror Screen® connection.

Display and content priority is given to the last phone used.

To change the priority of the phone:



Press the **"Phone"** application.



Press this button to change the priority of the phone.

Settings

Configuring the screen display

Press the **"Settings"** application.

In the list, select the **"Customisation"** tab.

It is possible to configure:

- the screen colours associated with the interior ambient lighting. Refer to the "Ease of use and comfort" section.
- the sound ambience.
- the visual welcome and goodbye animations.
- the screen transition animations.

Managing the system connectivity



Press the **"Settings"** application.

In the list, select the **"Connectivity"** tab.

It is possible to manage:

- The Bluetooth® connection.
- The Mirror Screen® smartphone connections (Apple® CarPlay®/Android Auto).

- The Wi-Fi connection.
- The privacy mode.

Configuring the system



Press the **"Settings"** application.

In the list, select the **"System"** tab.

It is possible to configure:

- the language.
- the date & time.
- the unit of distance and consumption (kWh/100 miles - miles, mi/kWh - miles, km/kWh - km).
- the temperature unit (Fahrenheit, Celsius).

It is also possible to reset the system configuration.

Selecting the language



Select **"Language"** to change the language.



Press the desired language.



Press the back arrow to return to the previous page.

Setting the date and time



Select **"Date and Time"** to modify the date and time.



Press the desired language.



"Automatic Date and Time" is activated by default, so that the setting is made automatically according to your geolocation.

To adjust manually, deactivate **"Automatic Date and Time"**.

Press the **"Select Time Zone"** field then define a time zone.



Press the back arrow to return to the previous page.

Press the **"Set Time"** line, then set the time.



Press this button to confirm.

Press the **"Set Date"** line, then set the date.



Press this button to confirm.



Select the Time Format field (12-hour / 24-hour).



Select the Date Format field (MM-DD-YY / YYYY-MM-DD / DD/MM/YYYY).

Note

The system does not automatically change between winter and summer time (depending on the country of sale).

User Manual



Select the display language.

The handbook home page is displayed.

It presents the different possibilities for accessing the information sought:

Visual search



Access to subjects via pictures representing the exterior and interior of the vehicle.

Indicator lamps



Access to the descriptions/operation of the instrument panel warning/indicator lamps.

System



Access to sections dedicated to the various audio equipment and telematics systems.

Contents



Access to subjects via the main sections of the handbook.

Visual search



Press Visual search.

Press one of the pictures located at the bottom of the screen.



Press one of the bullet points in the enlarged view.

There are two cases:

- Direct display of the subject, if only one subject is associated with the bullet point.
- Display of a list of subjects, if several subjects are associated with the bullet point.

Indicator lamps



Press **Indicator lamps**.

The mosaic of warning/indicator lamps is displayed.

The warning/indicator lamps are sorted by colour.

Press the warning/indicator lamp concerned; the corresponding content is displayed.



Back to the mosaic of warning/indicator lamps.

System

Press **System**.

The list of audio and telematics systems is displayed.

Press on the section concerned; the list of subjects is displayed.

Press on the subject concerned; the corresponding content is displayed.



If the subject has more than one page, drag horizontally.



Back to the list of subjects.

Contents

Press **Contents**.

The list of sections is displayed.

Press on the section concerned; the list of subjects is displayed.

Press on the subject concerned; the corresponding content is displayed.



If the subject has more than one page, drag horizontally.



Back to the list of subjects.

Starting & operating

Driving hints.....	107
Control of the vehicle.....	107
Steering.....	107
New vehicle running-in.....	108
Starting procedure.....	108
Stop-start system.....	109
Brakes.....	111
Anti-lock brake system (ABS).....	111
Parking brake.....	112
Brake assist.....	113
Active emergency braking.....	113
Hill start assist.....	113
Regenerative braking.....	114
Transmission.....	114
Hybrid 48V.....	114
PHEV.....	115
BEV.....	116
Driving modes.....	118
Hybrid 48V.....	118
PHEV.....	119
BEV.....	119
Engine exhaust.....	119
Exhaust filter.....	119
Fuel.....	120
Fuel for petrol engines.....	120
Refuelling.....	121
Fuel consumption and CO2 emissions	122
Charging.....	123
General information.....	123
Trailer towing.....	132

General information.....	132
Towing hitch.....	133
Trailer stability assist.....	136

Driving hints

CONTROL OF THE VEHICLE

Never coast with engine not running

Many systems will not function in this situation (e.g. brake servo unit, power steering). Driving in this manner is a danger to yourself and others.

All systems function during an Autostop.

Stop-start system → page 109.

Pedals

To ensure the pedal travel is uninhibited, there must be no mats in the area of the pedals.

Use only floor mats that fit properly and are fixed by the retainers on the driver side.

STEERING

If power steering assist is lost because the engine stops or due to a system malfunction, the vehicle can be steered but may require increased effort.

New vehicle running-in

Do not brake unnecessarily hard for the first few journeys.

During the first drive, smoke may occur because of wax and engine oil evaporating off the exhaust system.

Park the vehicle in the open for a while after the first drive and avoid inhaling the fumes.

During the running-in period, fuel and engine oil consumption may be higher.

Additionally, the cleaning process of the exhaust filter may take place more often.

Exhaust filter ⇒ page 119.

Starting procedure

Power button

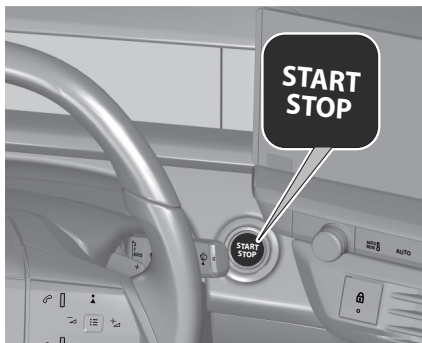

The electronic key must be inside the vehicle.

Engine start

Operate the brake pedal and press Start/Stop.

BEV

- Depress brake pedal.
- Press **Start/Stop** button for approx. two seconds.
- Keep the brake pedal depressed until **READY** is displayed in the cluster and an acoustic signal is given.

Ignition on power mode without starting the engine

Press **Start/Stop** without operating the brake pedal. Control indicators illuminate and most electrical functions are operable.

Engine and ignition off

Press **Start/Stop** briefly in each mode or when engine is running and vehicle is stationary. Some functions remain active until driver's door is opened.

Steering wheel lock

The steering wheel lock activates automatically when:

- the vehicle is stationary.
- the ignition has been switched off.

To release steering wheel lock, open and close driver's door and switch the ignition on power mode or start the engine directly.

Warning

If the vehicle battery is discharged, the vehicle must not be towed or tow-started as the steering wheel lock cannot be disengaged.

Warning

In the event of a fault of the key battery, the steering wheel lock remains engaged. Do not try to start the vehicle by pushing it and do not tow it.

Operation in case of failure

If either the electronic key fails or the battery of the electronic key is weak, a message may be displayed in the cluster.

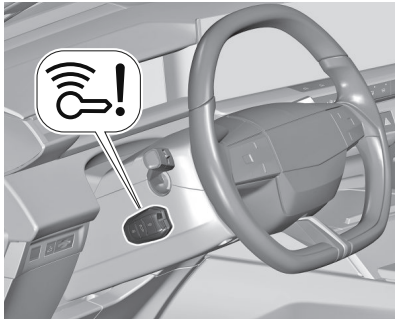

Hold the electronic key at the marking on the steering column cover as shown in the illustration.

On vehicles with manual transmission, select neutral gear, operate the clutch pedal, the brake pedal and press **Start/Stop**.

On vehicles with automatic transmission, move the selector to position **P**, operate the brake pedal and press **Start/Stop**.

This option is intended for emergencies only. Replace the electronic key battery as soon as possible.

For unlocking or locking the doors, see fault in radio remote control unit or electronic key system.

Emergency shut off during driving

If the engine needs to be switched off during driving in case of emergency, press **Start/Stop** for five seconds.

DANGER

Switching off the engine during driving may cause loss of power support for brake and steering systems. Assistance systems and airbag systems are disabled.

Lighting and brake lights will extinguish. Therefore power down the engine and ignition while driving only when required in case of emergency.

Starting the vehicle at low temperatures

Starting the engine without additional heaters is possible down to -30 °C for petrol engines.

Required is an engine oil with the correct viscosity, the correct fuel, performed services and a sufficiently charged vehicle battery.

At temperatures below -30 °C the automatic transmission requires a warming phase of approx. five minutes. The selector lever must be in position **P**.

Turbo engine warm-up

Upon start-up, engine available torque may be limited for a short time, especially when the engine temperature is cold. The limitation is to allow the lubrication system to fully protect the engine.

Stop-start system

The stop-start system helps to save fuel and reduce the exhaust emissions. When conditions allow, it switches off the engine as soon as the vehicle is at a low speed or at a standstill, e.g. at a traffic light or in a traffic jam.



Activation

By default, the system is activated when the ignition is switched on.

The system is ready to operate when the LED in the button is not illuminated.

To activate the system when the system is deactivated, press the button .

If the stop-start system is temporarily not available and the button is pressed, the LED in the button flashes.

The activation of the system is confirmed by a message.

Deactivation

Deactivate the stop-start system manually by pressing the button .

The deactivation is indicated when the LED in the button illuminates.

Autostop

Vehicles with automatic transmission

If the vehicle is at a standstill with depressed brake pedal, Autostop is activated automatically.

The engine will be switched off while the ignition stays on.

The stop-start system will be disabled on inclines of 12% or more.

Indication

An Autostop is indicated by control indicator .

During an Autostop, the heating and brake performance will be maintained.

Conditions for an Autostop

The stop-start system checks if each of the following conditions is fulfilled.

- The stop-start system is not manually deactivated.
- The driver's door is closed or the driver's seat belt is fastened.
- The vehicle battery is sufficiently charged and in good condition.
- The engine is warmed up.

- The engine coolant temperature is not too high.
- The engine exhaust temperature is not too high, e.g. after driving with high engine load.
- The ambient temperature is not too low or too high.
- The climate control system allows an Autostop.
- The brake vacuum is sufficient.
- The self-cleaning function of the exhaust filter is not active.
- The vehicle was driven at least at walking speed since the last Autostop.

Autostop will be inhibited if these conditions are not met. In addition, Autostop may be inhibited:

- by certain settings of the climate control system ⇔
- immediately after higher speed driving
- in the case of new vehicle running-in
- by active demisting
- in the case of steep ascending or descending slopes
- if the vehicle has not exceeded 6 mph since the last engine start

In these cases, the icon on the cluster flashes for a few seconds and then goes off.

Note

The Autostop may be inhibited for several hours after a battery replacement or reconnection.

Vehicle battery discharge protection

To ensure reliable engine restarts, several vehicle battery discharge protection features are implemented as part of the stop-start system.

Power saving measures

During an Autostop, several electric features such as auxiliary electric heater or rear window heating are disabled or switched to a power saving mode. The fan speed of the climate control system is reduced to save power.

Restart of the engine by the driver

The engine is restarted in the following cases:

- brake pedal released while the selector lever in position **D** or **M**
- brake pedal released or selector lever in position **N** when selector lever is moved to position **D** or **M**

- selector lever moved to position **R**

Restart of the engine by the stop-start system

If one of the following conditions occurs during an Autostop, the engine will be restarted automatically by the stop-start system:

- stop-start system manually deactivated
- driver's seat belt unfastened and driver's door opened
- engine temperature too low
- charging level of vehicle battery below a defined level
- brake vacuum not sufficient
- vehicle is driven or rolls at least at walking speed
- climate control system requests engine start
- air conditioning manually switched on

If an electric accessory, e.g. a portable CD player, is connected to the power outlet, a brief power drop during the restart might be noticeable.

Brakes

ANTI-LOCK BRAKE SYSTEM (ABS)

Anti-lock brake system (ABS) prevents the wheels from locking.

ABS starts to regulate brake pressure as soon as a wheel shows a tendency to lock. The vehicle remains steerable, even during hard braking.

ABS control is made apparent through a pulse in the brake pedal and the noise of the regulation process.

For optimum braking, keep the brake pedal fully depressed throughout the braking process, despite the fact that the pedal is pulsating. Do not reduce the pressure on the pedal.

When braking in an emergency, the hazard warning flashers are switched on automatically depending on the force of deceleration. They are switched off automatically the first time you accelerate.

After starting off, the system performs a self-test that may be audible.



Control indicator ⇨ page 111.

Fault

⚠ Warning

If there is a fault in the ABS, the wheels may be liable to lock due to braking that is heavier than normal. The advantages of ABS are no longer available. During hard braking, the vehicle can no longer be steered and may swerve.

Have the cause of the fault remedied by a workshop.

PARKING BRAKE

⚠ Warning

Before leaving the vehicle, check parking brake status. Control that indicator illuminates constantly when electric parking brake is applied.



Applying when vehicle is stationary

⚠ Warning

Pull (P) for a minimum of one second until control indicator (P) illuminates constantly and the electric parking brake is applied.

The electric parking brake operates automatically with adequate force.

Before leaving the vehicle, check the electric parking brake status. ⇨ page 74

The electric parking brake can always be activated, even if the ignition is off.

Do not operate the electric parking brake system too often without engine running as this will discharge the vehicle battery.

Releasing

Switch on the ignition. Keep the foot brake pedal depressed and then push the (P). If the (P) control indicator j extinguishes, the electric parking brake is released.

Drive away function

Vehicles with automatic transmission: Engaging **P**, **R**, **N** or **D** and then depressing the accelerator pedal releases the electric parking brake automatically. This is only possible if the automatic operation of the electric parking brake is activated. It is not



possible when (P) is pulled at the same time.

Braking when vehicle is moving

When the vehicle is moving and (P) is kept pulled, the electric parking brake system will decelerate the vehicle. As

soon as (P) is released, braking will be stopped.

The anti-lock brake system and the Electronic Stability Control stabilise the vehicle while the  is kept pulled. If an error of the electric parking brake occurs, a warning message is displayed on the cluster.

If the anti-lock brake system and the Electronic Stability Control fail, one or both of these control indicators  and  illuminate on the cluster. In this case, stability during deceleration of the vehicle can only be maintained with repeated short pulls of the switch until the vehicle is immobilised.



Automatic operation

Automatic operation includes automatic application and automatic release of the electric parking brake.

The electric parking brake can also be applied or released manually by using .

Deactivation of automatic operation

In certain situations, e.g. in extreme cold weather conditions or when towing, it may be necessary to deactivate the automatic operation of the electric parking brake.

1. Start the engine.
2. If the parking brake is released, pull  to apply the parking brake.
3. Take your foot off the brake pedal.
4. Press  for at least 10 seconds and maximum 15 seconds.
5. Release .
6. Depress and hold the brake pedal.
7. Pull the parking brake switch for two seconds.

Fault

Failure mode of electric parking brake is indicated by the control indicator ! and by a message displayed on the cluster.

Control indicator of parking brake flashes: electric parking brake is not fully applied or released. When continuously flashing, release electric parking brake and try applying it again.

BRAKE ASSIST

If the brake pedal is depressed quickly and forcefully, maximum brake force is automatically applied.

Operation of brake assist might become apparent by a pulse in the brake pedal and a greater resistance when depressing the brake pedal.

Maintain steady pressure on the brake pedal as long as full braking is required. Maximum brake force is automatically reduced when brake pedal is released.

ACTIVE EMERGENCY BRAKING

This system reduces the emergency stopping distance, by optimising the braking pressure. It is triggered in relation to the speed at which the brake pedal is depressed. The effect of this is a reduction in the resistance of the pedal and an increase in braking efficiency.

⇒ page 137

HILL START ASSIST

The system helps prevent unintended movement when driving away on inclines.

When releasing the brake pedal after stopping on an incline, brakes remain on for further two seconds. The brakes release automatically as soon as the vehicle begins to accelerate.

The system is active if the following conditions are met:

- vehicle stationary
- brake pedal depressed
- driver's door closed

REGENERATIVE BRAKING

Warning

In the case of extreme temperatures or if the high-voltage battery is almost fully charged, the brake force of the engine braking may be temporarily reduced. If the braking force is not sufficient, the driver must be prepared to use the brake pedal.

Warning

Depending on the engine braking force the brake lights are illuminated.

Regenerative braking generates electrical energy resulting from engine braking to charge the high-voltage battery.

Transmission

HYBRID 48V

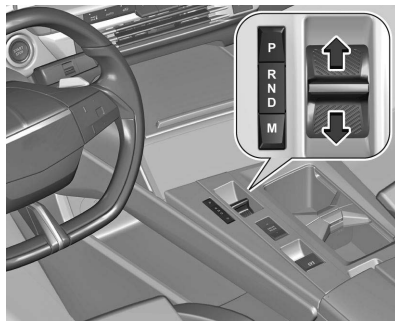

P : park mode

R : reverse mode

N : neutral mode

D : automatic mode

M : manual mode

Park mode P

To engage **P**, press button **P** when vehicle is stationary. In **P**, the front wheels of the vehicle are blocked.

To disengage **P**, depress the brake pedal and select the desired mode. **P** is automatically engaged when

- the ignition is switched off
- the driver's door is opened while the vehicle's speed is below 3 mph
- **N** has been selected for some time

Reverse mode R

To engage or disengage **R**, the vehicle must be at standstill and the brake pedal must be depressed.

CAUTION

Engaging **R** while the vehicle is moving forward could damage the automatic transmission. Only select **R** after the vehicle has been stopped.

Neutral mode N

In this mode, the propulsion system does not transfer torque to the wheels.

Automatic mode D

This mode is for normal driving.

Manual mode M

The selected gear is indicated in the cluster.

In this mode, it is possible to change gears manually using the steering wheel paddles.

Manual mode M can only be selected if D is engaged.

The selected gear is indicated in the cluster.

If a higher gear is selected when vehicle speed is too low, or a lower gear when vehicle speed is too high, the shift is not executed. This can cause a message in the cluster.

In manual mode, no automatic shifting to a higher gear takes place at high engine revolutions.

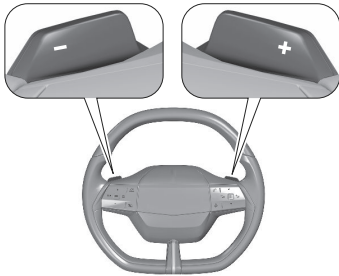

Press button M.

Pull steering wheel paddles to select gears manually.

Pull right paddle + to shift to a higher gear.

Pull left paddle - to shift to a lower gear.

Multiple pulls allow gears to be skipped.

Press M again to return into D.

Gear shift indication

The symbol ▲ with a number beside it is indicated when gear shifting is recommended for fuel saving reasons.

Electronic driving programmes

Following a cold start, the operating temperature programme increases engine speed to quickly bring the catalytic converter to the required temperature.

Special programmes automatically adapt the shifting points when driving up inclines or down hills.

In snowy or icy conditions or on other slippery surfaces, the electronic transmission control enables the driver to manually select first, second or third gear for starting off.

Fault

In the event of a fault,  illuminates a message is displayed on the cluster.

Vehicle messages⇒ page 73

Do not drive faster than 100 km/h.

Seek the assistance of a workshop.

Interruption of power supply

In the event of an interruption of power supply, it is not possible to select another mode when P is engaged.

Towing the vehicle⇒ page 185

If the vehicle battery is discharged, start the vehicle using jump leads.

Jump starting⇒ page 183

If the vehicle battery is not the cause of the fault, seek the assistance of a workshop.

PHEV

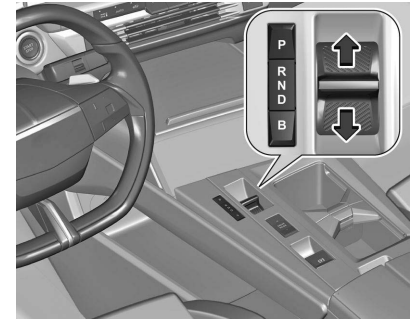

P : park mode

R : reverse mode

N : neutral mode

D : automatic mode

B : automatic mode with one-pedal driving

Park mode P

To engage **P**, press button **P** when vehicle is stationary. In **P**, the front wheels of the vehicle are blocked.

To disengage **P**, depress the brake pedal and select the desired mode. **P** is automatically engaged when

- the ignition is switched off
- the driver's door is opened while the vehicle's speed is below 3 mph
- **N** has been selected for some time

Reverse mode R

To engage or disengage **R**, the vehicle must be at standstill and the brake pedal must be depressed.

CAUTION

Engaging **R** while the vehicle is moving forward could damage the automatic transmission. Only select **R** after the vehicle has been stopped.

Neutral mode N

In this mode, the propulsion system does not transfer torque to the wheels.

Automatic mode D

This mode is for normal driving.

Automatic mode with one-pedal driving B

In this mode, vehicle speed is significantly reduced by releasing the accelerator pedal, without operating the brake pedal.

BEV

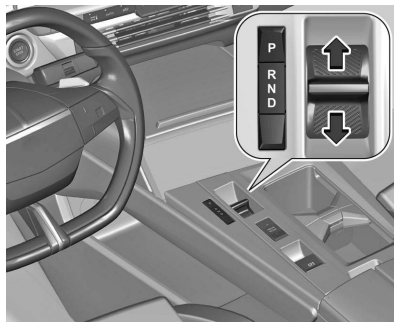

P : park mode

R : reverse mode

N : neutral mode

D : automatic mode

Park mode P

To engage **P**, press button **P** when vehicle is stationary. In **P**, the front wheels of the vehicle are blocked.

To disengage **P**, depress the brake pedal and select the desired mode. **P** is automatically engaged when

- the ignition is switched off
- the driver's door is opened while the vehicle's speed is below 3 mph
- **N** has been selected for some time

Reverse mode R

To engage or disengage **R**, the vehicle must be at standstill and the brake pedal must be depressed.

CAUTION

Engaging **R** while the vehicle is moving forward could damage the automatic transmission. Only select **R** after the vehicle has been stopped.

Neutral mode N

In this mode, the propulsion system does not transfer torque to the wheels.

Automatic mode D

This mode is for normal driving. In this mode, the paddles control the level of regenerative braking.

Regenerative braking mode with one-pedal driving

Warning

For more information, refer to the **General recommendations on the use of driving and manoeuvring aids.**

This system assists the driver in controlling the vehicle by action on the acceleration pedal only. The driver can control the vehicle with only one foot acting on the acceleration pedal in most driving situations.

The brake pedal will be used only for emergency situations.

Warning

This system is not intended to improve the vehicle energy efficiency.



Three braking levels are selectable.

The respective braking level is indicated by one to three triangle segments in the cluster.

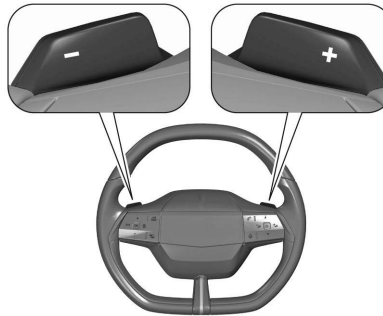

Pull left paddle - to increase the braking force and pull right paddle + to decrease.

Use the maximum braking force when driving down steep hills, in deep snow, in mud or in stop-and-go traffic.

Warning

In the case of extreme temperatures or if the high-voltage battery is almost fully charged, the brake force of the engine braking may be temporarily reduced. If the braking force is not sufficient, the driver must be prepared to use the brake pedal.

Operating conditions

- One pedal mode is active in forward and reverse drive.
- Deceleration is effective independently of the vehicle condition (e.g. battery SOC, vehicle speed) or situations (e.g. external temperature, slope), except in N drive selector position.
- Brake modes (with 1 or 2 levels of deceleration) may be available, independent of one pedal mode, depending on the vehicle configuration.
- When depressing the acceleration pedal to brake, the pedal stroke is long enough to allow the driver to control the deceleration rate without any dead-stroke.
- The vehicle deceleration control is done by lifting off the acceleration

pedal. Deceleration is kept until full stop.

- Auto hold of vehicle at full stop. No action is required from the driver to maintain the vehicle in position.

Activation/Deactivation

By default, the system is not selected. The state of the function is saved when the ignition is switched off.



- Press this button to select the system; this indicator light appears in green on the instrument panel.
- Press the button again until its indicator light on the instrument panel goes off.

Operating limits

Some users may find one foot operation difficult and feel uncomfortable or unsafe. One pedal driving may produce dizziness or unpleasant feeling to some passengers.

The system performance may be affected by:

- slippery roads
- heavy towing

Additional features

- One pedal mode is selected or cancelled by a direct and easily accessible physical control
- One pedal mode active in forward and reverse drive
- One pedal mode is memorised after vehicle key off

⚠ Warning

Some users may find one foot operation difficult and feel uncomfortable or unsafe. It must be possible to switch at any time to normal drive mode.

⚠ Warning

One pedal driving may produce dizziness or unpleasant feeling to some passengers.

Driving modes

To select the respective drive mode, use the shown toggle switch.

Propulsion types ⇒ page 2

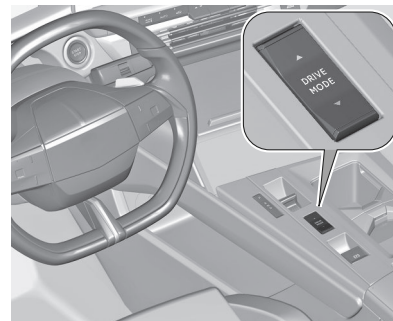

HYBRID 48V

The following drive modes are selectable.

Normal mode

The settings in this mode are set by default. Every time the ignition is switched on, this mode is selected.

Sport mode

This mode allows to obtain a more dynamic driving with action on the power steering, accelerator and gear changes. Depending on version, it is possible to display the vehicle's dynamic settings on the instrument panel and activate / deactivate the display colour.

Eco mode

This mode reduces the fuel consumption by optimising the operation of the heating

and air conditioning. While coasting the vehicle, the engine is idling with reduced engine brake.

PHEV

The following drive modes are selectable.

Electric mode

This mode allows 100% electric driving.

The maximum speed is approx.

135 km/h.

This mode is selected by default when the vehicle is started. If the conditions do not allow this mode, a message is displayed and hybrid mode is selected.

Hybrid mode

This mode optimises the vehicle's fuel consumption by simultaneous or alternation operation of internal combustion engine and electrical engine depending on driving conditions and driving style.

In this mode, driving 100% electrically is possible if the charge level of the high-voltage battery is sufficient and acceleration requirements are modest.

Sport mode

This mode allows more dynamic driving. Electric energy is used to support the internal combustion engine as long as there is enough electric energy left in the high-voltage battery.

BEV

The following drive modes are selectable.

Normal mode

The settings in this mode are set by default. Every time the ignition is switched on, this mode is selected.

To optimise range, electric engine power output is reduced.

Sport mode

The settings in this mode allow more dynamic driving. The vehicle's dynamic parameters can be displayed in the cluster.

This mode allows maximum electric engine power output.

Eco mode

To optimise range, electric engine power output and heating are reduced.

Tip

Kick-down

In **Normal** and **Eco** modes, it is always possible to obtain maximum torque and power by depressing the accelerator pedal fully.

Engine exhaust

DANGER

Engine exhaust gases contain poisonous carbon monoxide, which is colourless and odourless and could be fatal if inhaled.

If exhaust gases enter the interior of the vehicle, open the windows.

Have the cause of the fault rectified by a workshop.



Avoid driving with an open load compartment, otherwise exhaust gases could enter the vehicle.

EXHAUST FILTER

Automatic cleaning process

The exhaust filter system filters soot particles out of the exhaust gases.

The start of saturation of the exhaust filter is indicated by the temporary



illumination of  or , accompanied by a message in the cluster.

As soon as the traffic conditions permit, regenerate the filter by driving at a vehicle speed of at least 60 km/h until the control indicator extinguishes.

Note

On a new vehicle, the first exhaust filter regeneration operations may be accompanied by a burning smell, which is normal. Following prolonged operation of the vehicle at very low speed or at idle, water vapour can be emitted at the exhaust on acceleration. This does not affect the behaviour of the vehicle or the environment.

Cleaning process not possible

If  or  stays on, accompanied by an audible signal and a message, this indicates that the exhaust filter additive level is too low.

The reservoir must be topped-up without delay. Seek the assistance of a workshop.

Catalytic converter

The catalytic converter reduces the amount of harmful substances in the exhaust gases.

Note

Fuel grades other than those listed could damage the catalytic converter or electronic components.

Unburnt petrol will overheat and damage the catalytic converter.

Therefore avoid excessive use of the starter, running the fuel tank dry and starting the engine by pushing or towing.

In the event of misfiring, uneven engine running, a reduction in engine performance or other unusual problems, have the cause of the fault rectified by a workshop as soon as possible. In an emergency, driving can be continued for a short period, keeping vehicle speed and engine speed low.

Fuel

FUEL FOR PETROL ENGINES

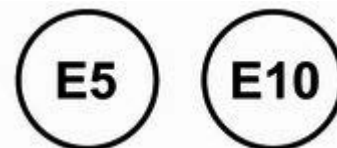

Only use unleaded fuel that complies with European standard EN 228 or E DIN 51626-1 or equivalent.

The engine is capable of running with fuel that contains up to 10% ethanol (e.g. named E10).

Use fuel with the recommended octane rating. A lower octane rating can reduce engine power and torque and slightly increases fuel consumption.

Note

The only petrol additives authorised for use are those that meet the B715001 standard.

CAUTION

Do not use fuel or fuel additives that contain metallic compounds such as manganese-based additives. This may cause engine damage.

CAUTION

Use of fuel with a lower octane rating than the lowest possible rating could lead to uncontrolled combustion and engine damage.

The engine specific requirements regarding octane rating are given in the engine data overview. A country-specific label at the fuel filler flap can supersede the requirement.

In certain countries, the use of a particular fuel, e.g. a specific octane rating, may be required to ensure proper engine operation.

REFUELLING**⚠ DANGER**

Before refuelling, switch off ignition and any external heaters with combustion chambers.

Follow the operating and safety instructions of the filling station when refuelling.

⚠ DANGER

Fuel is flammable and explosive.

No smoking. No naked flames or sparks.

If you can smell fuel in your vehicle, have the cause of this remedied immediately by a workshop.

A label with symbols at the fuel filler flap is indicating the allowed fuel types. In Europe the pump nozzles of the filling stations are marked with these symbols. Refuel only the allowed fuel type.

CAUTION

In case of misfuelling, do not switch on ignition.

The fuel filler flap is located at the rear right side of the vehicle.



The fuel filler flap can only be opened if the vehicle is unlocked. Release the fuel filler flap by pushing the flap.

To open, turn the cap slowly anticlockwise.



Place the nozzle in straight position to the filler neck and press with slight force to insert.

To refuel, switch on the pump nozzle.

After the automatic cut-off, the tank can be topped up by operating the pump nozzle a maximum of two more times.

CAUTION

Wipe off any overflowing fuel immediately.

To close, turn the fuel filler cap clockwise.

Close the flap and allow it to engage.

Fuel filler cap

Only use genuine fuel filler caps.

General information

For the values specific to your vehicle, refer to the Certificate of Conformity provided with your vehicle or other national registration documents.

The determination of fuel consumption is regulated by directive R (EC) No.715/2007 and No.2017/1151 (in the latest applicable version).

The specification of CO₂ emission is also a constituent of the directive.

The figures given must not be taken as a guarantee for the actual fuel consumption of a particular vehicle.

Furthermore, fuel consumption is dependent on personal driving style as well as road and traffic conditions.

All values are based on the EU base model with standard equipment.

The calculation of fuel consumption takes into account the vehicle's kerb weight, ascertained in accordance with the regulations. Optional equipment may result in slightly higher fuel consumption and CO₂ emission levels and a lower maximum speed.

FUEL CONSUMPTION AND CO₂ EMISSIONS

All values are combined values under WLTP condition.

48V Hybrid: The fuel consumption is within a range of 5.5 to 5.6 l/100 km and the CO₂ emissions within a range of 123 to 127 g/km

PHEV: The fuel consumption is within a range of 0.8 to 0.9 l/100 km and the CO₂ emissions within a range of 19 to 21 g/km

Propulsion types ⇒ page 2

General information

For the values specific to your vehicle, refer to the Certificate of Conformity provided with your vehicle or other national registration documents.

The determination of fuel consumption is regulated by directive R (EC) No.715/2007 and No.2017/1151 (in the latest applicable version).

The specification of CO₂ emission is also a constituent of the directive.

The figures given must not be taken as a guarantee for the actual fuel consumption of a particular vehicle.

Furthermore, fuel consumption is dependent on personal driving style as well as road and traffic conditions.

All values are based on the EU base model with standard equipment.

The calculation of fuel consumption takes into account the vehicle's kerb weight, ascertained in accordance with the regulations. Optional equipment may result in slightly higher fuel consumption and CO₂ emission levels and a lower maximum speed.

Charging

GENERAL INFORMATION

Warning

Persons with a pacemaker should consult a doctor for possible precautions.

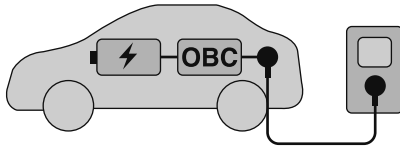

- internal onboard charger (OBC)
- external charging device
- charging cable

The charging cable connects the vehicle's high-voltage battery with an external charging device providing electric power. This may be a domestic

electrical outlet, a Green'Up outlet, a wall box or a public charging station.

The high-voltage battery can be charged with direct current (DC) only.

When charging from a domestic electrical outlet, a wall box or an alternating current (AC) charging station, AC has to be converted into DC. This is done by the vehicle's onboard charger.

PHEV: The onboard charger (single phase) is available with 3.7 kW or 7.4 kW.

BEV: The onboard charger (3-phase) is available with 11 kW.

The speed of charging the vehicle's high-voltage battery depends upon the weakest element of the charging chain. To achieve the maximum charging speed, charging cable and charging device must be attuned to each other.

Note

Make sure that the charging cable used fits to the vehicle's onboard charger.

Warning

In case of impact, even light, against the charging flap, do not use it.

Do not dismantle or modify the charging connector - risk of electrocution and/or fire!

Contact a Vauxhall dealer or a qualified workshop.

Electric power consumption and range

The electric power consumption (combined under WLTP condition) is within a range of 21.9 to 23.4 kWh/100 km.

The all electric range is up to 87 km (PHEV) / 523 km (BEV with FDB battery) or 585 km (BEV with ACC battery).

For the values specific to your vehicle, refer to the Certificate of Conformity provided with your vehicle or other national registration documents.

The determination of electric power consumption is regulated by directive R (EC) No. 715/2007 and No.

2017/1151 (in the latest applicable version).

High-voltage battery

⚠ Warning

Damage to the high-voltage battery or high-voltage system can create a risk of electric shock, overheating or fire.

If the vehicle has been damaged or affected by a moderate to severe crash, it must be inspected as soon as possible by qualified personnel. Until the technical inspection has been carried out, the vehicle must be stored outside at a minimum distance of 5 metres from any structure or other flammable objects.

If the vehicle has been damaged or affected by flood or fire, it must not be moved at all and must be inspected by qualified personnel as soon as possible.

To preserve the range and the durability of the high-voltage battery, the following is recommended:

- Whenever possible, do not charge the high-voltage battery more than 80%.
- Do not completely discharge the high-voltage battery.
- Do not store the vehicle for a long period of non-use (more than 12 hours)

when the high-voltage battery has a low or high charge level. Prefer a charge level between 20 and 40%.

- Limit the use of fast charging.
- Do not expose the vehicle to temperatures below $-30\text{ }^{\circ}\text{C}$ and above $60\text{ }^{\circ}\text{C}$ for more than 24 hours.
- Avoid charging the vehicle at low temperatures (except if the vehicle ran more than 20 minutes) or above $30\text{ }^{\circ}\text{C}$.
- Do not use the high-voltage battery as a generator of energy.
- Do not use a generator to recharge the high-voltage battery.

Leakage

Damage to the high-voltage battery could result in the leakage of toxic gases or fluids either immediately or later. The following is recommended:

- In the event of an incident, always inform the fire and emergency services that the vehicle is equipped with a high-voltage battery.
- Never touch the liquids leaking from the high-voltage battery.
- Do not inhale the gases emitted by the high-voltage battery, which are toxic.

- Move away from the vehicle in the event of incident or accident, the gases emitted being flammable and could cause a fire.
- Too low a coolant level must be topped up and the cause of the coolant loss remedied by a workshop.

Charging types

There are different types of charging the vehicle's high-voltage battery.

Charging times refer to charging an empty battery until it is completely charged.

Charging at wall boxes / AC charging stations

A wall box / AC charging station may or may not provide a charging cable which has to be connected to the vehicle's charging port.



PHEV: Charging time takes approx. three hours and 25 minutes with the 3.7 kW onboard charger and 16 A. For the 7.4 kW onboard charger with 32 A, charging time takes approx. one hour and 40 minutes.

BEV: Charging time takes approx. five hours with the 11 kW onboard charger.

Charging at DC charging stations



Up to approx. 80% of battery capacity may be charged in approx. 30 minutes at a charging power of 100 kW.

Charging at Green'Up outlets

The high-voltage battery can be charged at a Green'Up outlet. Connect the charging cable to the vehicle's charging port and to the Green'Up outlet.

PHEV: Charging time takes approx. three hours and 55 minutes.

Charging at domestic electrical outlets



Up to approx. 80% of battery capacity may be charged in approx. 30 minutes at a char

The high-voltage battery can be charged at a domestic electrical outlet. Connect the charging cable to the vehicle's charging port and to the domestic electrical outlet.

PHEV: Charging time takes approx. seven hours and five minutes.

BEV: Charging time takes approx. 30 hours.

Charging cable

Depending on the charging type, different charging cables are used.

⚠Warning

Improper use of portable charging cables may cause a fire, electrical shock or burns, and may result in damage to property, serious injury or death.

- Do not use extension cables, multi-outlet power strips, splitters, earthing adaptors, surge protectors or similar devices.
- Do not use an electrical socket that is worn or damaged, or one that will not hold the plug firmly in place.
- Do not immerse the charging cable into any liquid.
- Do not use an electrical socket that is not properly earthed.
- Do not use an electrical socket that is on a circuit with other electrical loads.

⚠Warning

Read all the safety warnings and instructions before using this product. Failure to follow the warnings and the instructions may result in electric shock, fire and / or serious injury.

Never leave children unattended near the vehicle while the vehicle is charging and never allow children to play with the charging cable.

If the plug provided does not fit the electrical outlet, do not modify the plug. Arrange for a qualified electrician to inspect the electrical outlet.

Do not put fingers into the electric vehicle connector.

⚠Warning

There is a risk of electric shock that may cause personal injury or death.

Do not use the charging cable if any part of the charging cable is damaged.

Do not open or remove the charging cable cover.

Service by qualified personnel only. Connect the charging cable to a properly earthed outlet with cables that are not damaged.

Basic domestic cable (mode 2) / enhanced domestic cable (mode 2)

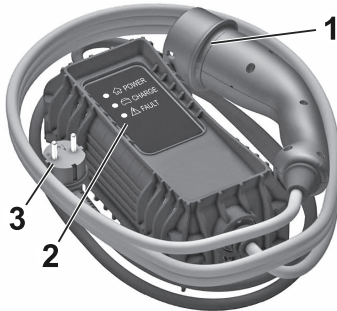

- 1: Vehicle plug
- 2: Status indicators
- 3: Wall plug

Basic domestic cables (mode 2) are used for charging at domestic electrical outlets. A basic domestic cable (mode 2) consists of a vehicle plug, a control box and a plug for the domestic electrical outlet. The control box has an integrated charge controller and several LEDs indicating the charging status.

Enhanced domestic cables (mode 2) are similar to basic domestic cables (mode

2). However, the charging performance of enhanced domestic cables (mode 2 charging) is better than the charging performance of basic domestic cables (mode 2).

Enhanced domestic cables (mode 2) are used for Green'Up sockets, which must be installed by a certified electrician at the customer's site.

Charging cable status indicators

After plugging in the charging cable, it will perform a quick self-test and all status indicators illuminate for a moment. For the functions of the status indicators, refer to the manual of the charging cable manufacturer.

Important information about portable electric vehicle charging

- Charging an electric vehicle can stress a building's electrical system more than a typical household appliance.
- Before you plug into any electrical outlet, have a qualified electrician inspect and verify the electrical system (electrical outlet, wiring, junctions and protection devices) for heavy-duty service at a 10 A continuous load.

- Electrical outlets may wear out with normal usage or be damaged over time, making them unsuitable for electric vehicle charging.
- Check the electrical outlet / plug while charging and discontinue use if the electrical outlet / plug is hot, then have the electrical outlet serviced by a qualified electrician.
- When outdoors, plug into an electrical outlet that is weatherproof while in use.
- Mount the charging cable to reduce strain on the electrical outlet / plug.

Mode 3 charging cable



- 1: Vehicle plug

2: Plug for wall box / AC charging station

Mode 3 charging cables are used for charging at wall boxes and AC charging stations. A mode 3 charging cable provides a vehicle plug and a plug for the wall box / AC charging station. Wall boxes / AC charging stations may provide an integrated mode 3 charging cable. For more information on the mode 3 charging cable, refer to the manual of the charging cable manufacturer.

Mode 4 charging cable

Note

Only use DC charging cables shorter than 30 metres.

Mode 4 charging cables are used for DC charging. Since mode 4 charging cables are integrated within DC charging stations, they only provide a vehicle plug.

Charging

Warning

Persons with a pacemaker or similar devices should consult a doctor for possible precautions.

If in doubt, during charging do not remain inside or near the vehicle, near the charging cable or the charging unit.

In order to ensure the compatibility of plug and outlet, a label is used. The label is located on the inside of the vehicle's charging port flap. Make sure to connect only a cable of the same type.



Type 2 plug or outlet used for AC charging



FF plug or outlet used for DC charging

Warning

Avoid any entry of fluids into the charging port of the vehicle, the vehicle plug of the charging cable and the domestic electrical outlet.

When charging at a public AC charging station / public DC charging station,

follow the instructions for the use of the respective charging station. Public AC charging stations may not provide an integrated charging cable. In this case, a portable mode 3 charging cable is required.

Warning

When charging at a domestic electrical outlet, only use an outlet that is properly earthed and protected by a 30 mA differential switch.

Only use a domestic electrical outlet protected by a circuit breaker adapted to the amperage of the electrical circuit.

Have a qualified electrician check the electrical installation to be used. The installation must be in compliance with national standards and compatible with the vehicle.

When using a dedicated domestic electrical outlet, have it installed by a qualified electrician.

Make sure that the electrical outlet, the plug and the cable do not support the weight of the control box.

⚠ Warning

The engine does not start if the charging cable is connected to the vehicle. A warning is displayed in the cluster.

During the charging process, unlocking the vehicle will interrupt charging. If no action is taken on tailgate, the doors or the charging nozzle, the vehicle will lock again after 30 seconds and charging will resume automatically.

Do not work in the engine compartment. Some areas remain very hot, even an hour after charging and the fan may start at any time.

⚠ Warning

Make sure that the charging port flap is closed.

Do not leave the charging cable connected to the domestic electrical outlet.

1. Press P and switch off the vehicle.

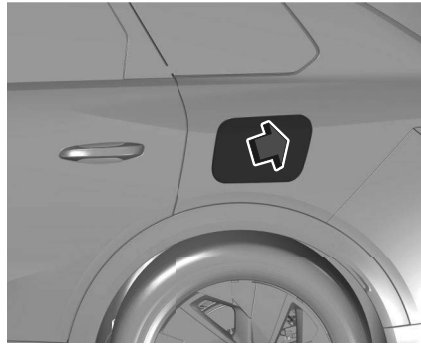

2. Push the charging port flap to release it.
3. If necessary, take the charging cable out of the load compartment.
4. If necessary, plug in the plug of the charging cable into the corresponding port of the external power source.
5. If necessary, remove the protective cover from the vehicle plug of the charging cable.

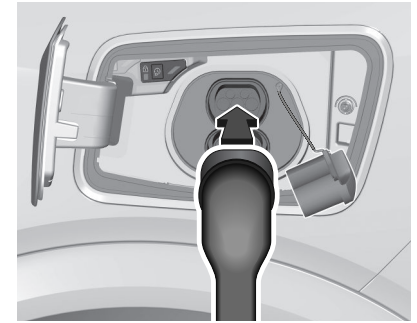

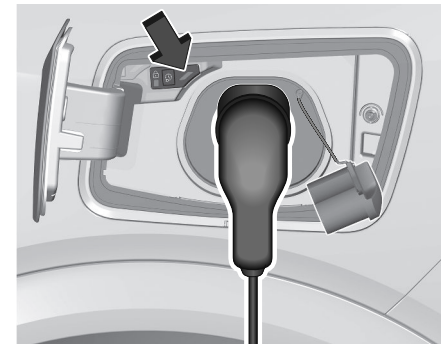

6. Plug in the vehicle plug of the charging cable into the charging port of the vehicle.

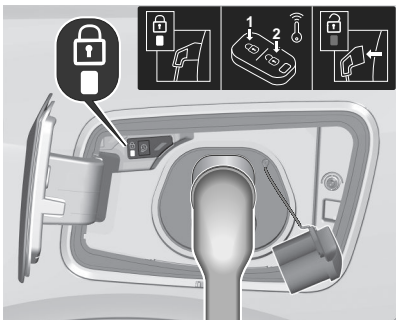

The start of charging is indicated by the green flashing of the status indicator at the charging port and at the control box of the charging cable if available.

Charging status⇒ page 132





Once charging, the vehicle plug will be locked to the charging port and cannot be disconnected while charging is active.  indicator illuminates.

Cancelling the charging process

Note

At public charging stations, the cancelling and subsequent resuming of the charging process may cause additional costs. Once the charging process has started, only the driver's door can be unlocked without cancelling the charging process. Therefore, activate the driver's door only function in the vehicle personalisation.

Press  on the remote control to cancel the charging process at any time.

Press  twice to cancel the charging process at any time if the function driver's door only is activated in the vehicle personalisation.

Central locking system⇒ page 8

Vehicle personalisation⇒ page 71

Stop charging

The high-voltage battery is fully charged if the status indicator on the charging port permanently illuminates green.

1. Unlock the vehicle before removing the vehicle plug from the charging port.

If the vehicle is already unlocked, lock the vehicle and unlock it again.

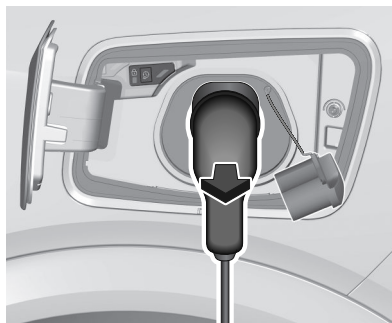

2. Disconnect the vehicle plug of the charging cable from the charging port within 30 seconds after unlocking.
3. Close the charging port flap by pressing firmly in the centre to latch properly.
4. Disconnect the charging cable from the external power source.
5. If necessary, store the charging cable in the load compartment.

While the charging cable is plugged into the vehicle, the vehicle cannot be driven.

Programmable charging

By default, charging starts as soon as the charging cable is connected to the charging port of the vehicle. It is also possible to schedule charging using the Info Display.

Programmable charging is only possible when charging at a domestic electrical outlet / Green'Up socket or a wall box.

Programmable charging is also available via the MyVauxhall App.

Note

On vehicles without integrated navigation system, programmable charging can only be used via the MyVauxhall App.

Battery Charging Limit 80%

It is possible to active/deactivate a limitation of the traction battery charging to 80% of its capacity.

80% charging is recommended for daily use. It may improve performance and durability.

Full charging is recommended for a long trip and will take longer.

Note



80% charging limit, when activated, is only applied to modes 2 and 3.

Deferred charging is only possible with modes 2 and 3.

- After programming the deferred charging, connect the vehicle to the desired charging equipment.

1. Press 



2. Touch 
3. Select Charging
4. Touch 
5. Define the number of hours and minutes after which the charging process starts.
6. Touch **OK**.
7. Plug in the vehicle.

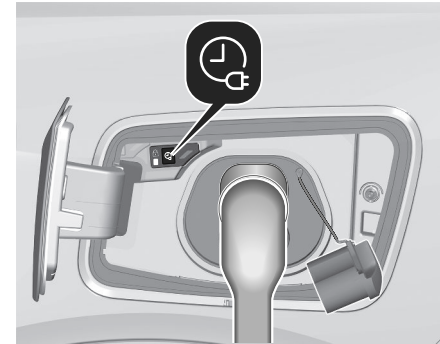

8. Within one minute, press  to activate programmable charging.
9. Depending on version, lock the vehicle.

The status indicator illuminates blue indicating that programmable charging is active.

Charging status

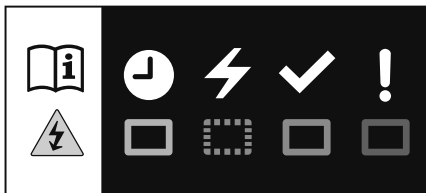

If the vehicle is plugged in and the ignition is switched off, the charging status indicator indicates the following:

- Illuminates white: welcome lighting when charging port flap is opened
- Illuminates green: charging complete
- Flashes green: charging in process
- Illuminates blue: programmable charging active
- Illuminates red: malfunction

A malfunction may be caused by the vehicle or the electrical installation at the customer's site.

Further charging status indicators are located on the control box of the basic domestic cable (mode 2) / enhanced domestic cable (mode 2).

Charging cable ⇒ page 126

Programmable charging ⇒ page 130

Trailer towing

GENERAL INFORMATION

CAUTION

For new vehicles, only tow a trailer after having driven at least 1000 km.

Only use towing equipment that has been approved for your vehicle.

Entrust retrofitting of towing equipment to a workshop. It may be necessary to make changes that affect the cooling system, heat shields or other equipment.

Fitting of towing equipment could cover the opening of the towing eye.

If this is the case, use the coupling ball bar for towing. Always keep the coupling ball bar in the vehicle to have it on hand if needed.

Trailer loads

The permissible trailer loads are vehicle and engine-dependent maximum values that must not be exceeded. The actual trailer load is the difference between the

actual gross weight of the trailer and the actual coupling socket load with the trailer coupled.

The permissible trailer loads are specified in the vehicle documents. In general, they are valid for inclines up to 12%.

The permissible trailer load applies up to the specified incline and at sea level. Since engine power decreases as altitude increases due to the air becoming thinner, therefore reducing climbing ability, the permissible gross train weight also decreases by 10% for every 1000 m of altitude. The gross train weight does not have to be reduced when driving on roads with slight inclines (less than 8%, e.g. motorways).

The permissible gross train weight must not be exceeded. This weight is specified on the identification plate ⇒ page 202.

Vertical coupling load

Warning

If attaching accessories to the trailer hitch such as bicycle carriers, tow boxes etc., do comply with the maximum permissible vertical coupling load.

When using a bicycle carrier, do not transport more than four conventional bicycles or two electric bicycles. Make sure to place the heaviest bicycle as close as possible to the vehicle.

The vertical coupling load is the load exerted by the trailer on the coupling ball. It can be varied by changing the weight distribution when loading the trailer.

The maximum permissible vertical coupling load 80 kg is specified on the towing equipment identification plate and in the vehicle documents.

Always aim for the maximum vertical coupling load, especially in the case of heavy trailers. The vertical coupling load should never fall below 25 kg.

Rear axle load

When the trailer is coupled and the towing vehicle fully loaded, the

permissible rear axle load (see identification plate or vehicle documents) may be exceeded by 60 kg, the gross vehicle weight rating must not be exceeded. If the permissible rear axle load is exceeded, a maximum speed of 60 mph applies.

Driving characteristics and towing tips

Before attaching a trailer, lubricate the coupling ball. However, do not do so if a stabiliser, which acts on the coupling ball, is being used to reduce snaking movements.

During trailer towing do not exceed a speed of 80 km/h. A maximum speed of 100 km/h is only appropriate if an oscillation damper is used and the permissible gross trailer weight does not exceed the vehicle's kerb weight.

For trailers with low driving stability and caravan trailers, the use of an oscillation damper is strongly recommended.

If the trailer starts snaking, drive more slowly, do not attempt to correct the steering and brake sharply if necessary.

When driving downhill, drive in the same gear as if driving uphill and drive at a similar speed.

Adjust tyre pressure to the value specified for full load.

TOWING HITCH

CAUTION

When operating without a trailer, remove the coupling ball bar.

Stowage of the coupling ball bar without double load floor

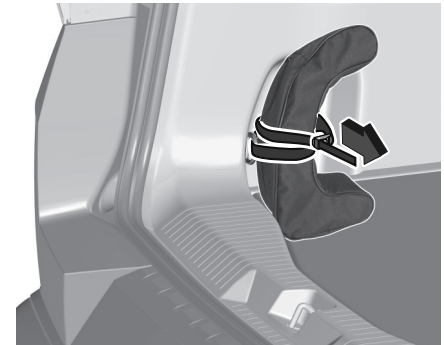

The bag with the coupling ball bar is stowed in the left stowage space in the load compartment.

Place the strap through the rear left lashing eye, wrap around twice and tighten the strap to secure the bag.

Stowage of the coupling ball bar with double load floor

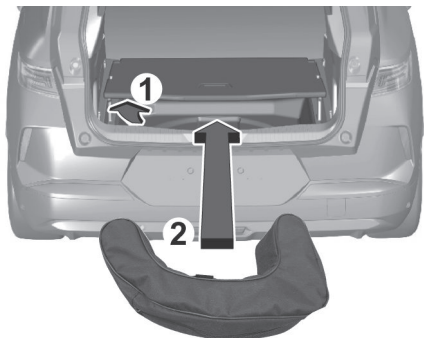

Lift the double load floor and stow the bag with the coupling ball bar underneath.

Fitting the coupling ball bar

Stowage of the coupling ball bar with double load floor Lift the double load floor and stow the bag with the coupling ball bar underneath.

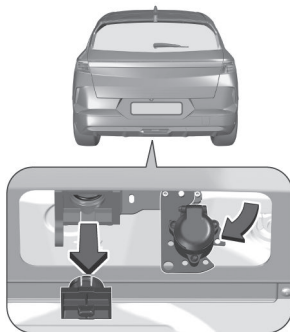

Remove the sealing plug from the opening for the coupling ball bar and stow it.

Inserting the coupling ball bar



Make sure the mechanism is unlocked (only red mark is visible).

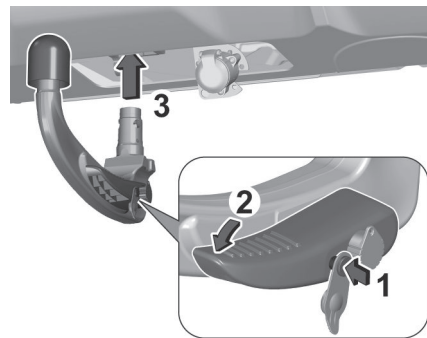

Insert the coupling ball bar in the opening and push firmly upwards until it audibly engages.

The handle should snap upwards.

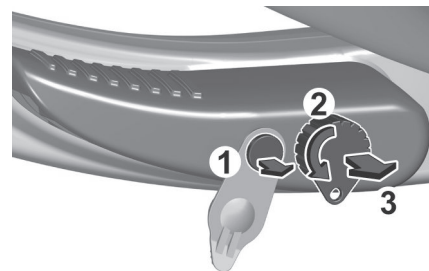

Close the lock using the key by turning it anti-clockwise and pulling it.

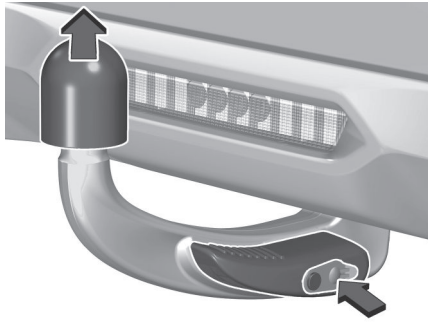

Clip the cap onto the lock.

Remove the protective cover from the towball.

Checking the correct installation of the coupling ball bar

- The mechanism must be locked (green mark is fully visible).
- The lock must be closed.
- The key must be removed. The key can only be removed when the lock is closed.
- The cap must be clipped onto the lock
- The protective cover must be removed

Warning

Towing a trailer is permitted only when a coupling ball bar is fitted correctly. If the coupling ball bar does not engage correctly, seek the assistance of a workshop.

Eye for break-away stopping cable

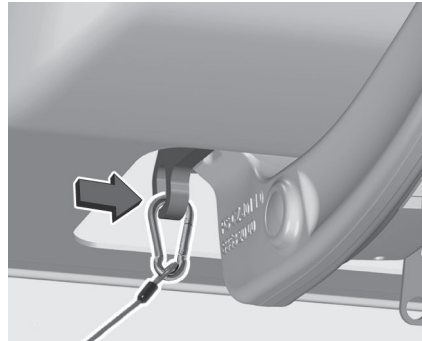

Attach the breakaway stopping cable to eye.

Connecting the power socket

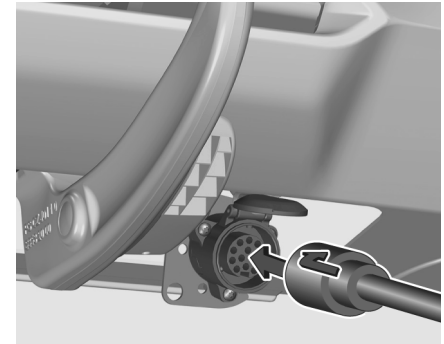

Open the protective cover for the plug. Insert the plug and perform a clockwise quarter turn to lock it in place.

Dismounting the coupling ball bar

- Grasp the power plug, perform an anticlockwise quarter turn and pull it out of the socket.
- Detach the breakaway stopping cable from the safety eye.
- Unclip the cap from the lock.
- Insert the key and open the lock by turning clockwise.
- Hold the towball with one hand and push on the lever to release it.

- Replace the protective cover on the towball and the sealing plug in the opening on the carrier.
- Replace the towball in its bag to protect it and stow it.

TRAILER STABILITY ASSIST

If the system detects snaking movements, engine power is reduced and the vehicle / trailer combination is selectively braked until the snaking ceases. While system is working keep steering wheel as still as possible. The system operates from 60 km/h to 160 km/h.

Warning

In some situations, the system may not detect trailer snaking, e.g. when towing a light trailer. On slippery or poor surfaces, the system may not be able to prevent sudden trailer snaking.

Advanced driving assistance systems

Driving recommendations / manoeuvring aids.....	137
Active Emergency Braking (AEB).....	137
Forward Collision Warning (FCW)....	142
Vehicle stability assistance system...	144
Anti-slip regulator (ASR).....	144
Electronic Stability Control (ESC)...	145
Side Blind Spot Alert (SBSA).....	145
Lane Departure Warning (LDW).....	147
Lane Keeping Assist (LKA).....	148
Semi-automatic lane changing.....	150
Lane positioning assist (LPA).....	152
Parking assist.....	155
Rear View Camera (RVC).....	157
Panoramic view system.....	159
Rear cross traffic alert.....	162
Driver drowsiness detection.....	163
Speed limiter.....	165
Adaptive cruise control.....	166
Tyre deflation detection system.....	171
Traffic Sign Assist (TSA).....	172

Driving recommendations / manoeuvring aids

⚠ Warning

Driver assistance systems are developed to support the driver and not to replace the driver's attention.

The driver accepts full responsibility when driving the vehicle.

When using driver assistance systems, always take care regarding the current traffic situation.

Note

To comply with the European general safety regulations, some driver assistance systems can only be deactivated on the Info Display until the next time the ignition is reactivated. The system is automatically activated by default every time the engine is started.

Active Emergency Braking (AEB)

Active emergency braking can help to reduce the damage and injury from crashes with vehicles, pedestrians and cyclists directly ahead, when the driver does not actively take action either by manual braking or by steering.

Before the active emergency braking applies, the driver will be warned by the forward collision alert. ⇒ page 142

The feature uses various inputs (e.g. camera sensor, radar sensor) to calculate the probability of a frontal collision.

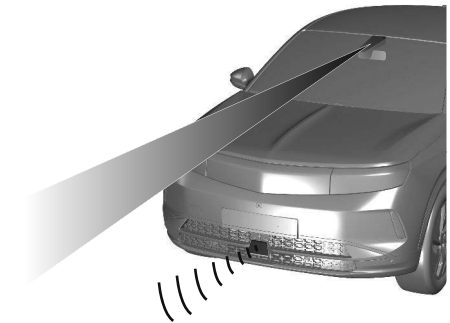

⚠ Warning

This system is not intended to replace the driver's responsibility for driving the vehicle and looking ahead. It warns the driver if the vehicle is at risk of a collision with the preceding vehicle, a pedestrian or a cyclist. Just before the imminent collision, it reduces the vehicle's speed to avoid a collision or to limit its severity.

The system may also react on animals. However, animals smaller than 0.5 m or objects on the road may not be detected.

After a sudden lane change, the system needs a certain time to detect the next preceding vehicle.

The driver must always be ready to take action and apply the brakes and steer to avoid collisions.

The driver can override the automatic emergency braking by strongly turning the steering wheel and / or by pressing firmly the accelerator pedal.

To ensure the pedal travel is uninhibited, there must be no food or mats in the area of the pedals.

Activation/deactivation

Depending on version, the system is automatically active by default every time the engine is started, even if it was deactivated during the last ignition cycle.

For further information ⇒ page 137

The system can be activated or deactivated on the Info Display via the

vehicle settings .

Info Display ⇒ page 68

Depending on version, deactivation is only possible at a standstill.

If deactivated,  illuminates and a message is shown on the cluster.

Functionality

Depending on the vehicle configuration and the detected objects, there are several operational speed ranges.

Active emergency braking operates up to 80 km/h when a pedestrian or a cyclist has been detected.

On vehicles equipped with radar sensor and front camera, the active emergency braking operates up to 80 km/h when a stationary vehicle or a motorcyclist has been detected.

On vehicles equipped with radar sensor and front camera, the active emergency braking operates from 8 km/h to 140 km/h when a moving vehicle has been detected.

Active emergency braking operates up to 80 km/h when a pedestrian or a cyclist has been detected.

On vehicles equipped with radar sensor and front camera, the active emergency braking operates up to 80 km/h when a stationary vehicle or a motorcyclist has been detected.

On vehicles equipped with radar sensor and front camera, the active emergency braking operates from 8 km/h to 140 km/h when a moving vehicle has been detected.

The system includes the following functions:

- forward collision warning
- emergency brake assist
- automatic braking forward collision warning

Forward collision warning ⇒ page 142

Turning manoeuvre

The system may also operate during a turning manoeuvre when detecting

another vehicle, a motorcyclist or a pedestrian.

Crossing the road with another vehicle

On vehicles equipped with radar sensor and front camera: The system may operate when the vehicle is turning and detects another vehicle on the adjacent lane, approaching from the opposite direction, if the following conditions are met:

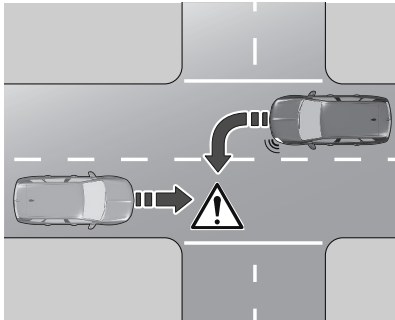

- the corresponding turn light is activated
- the vehicle is about to cross the driving path of another vehicle
- the vehicle speed is between 8 km/h and 25 km/h

- a collision with another vehicle is probable. In addition, the system also reacts to motorcyclists.

Crossing road with a pedestrian

The system may operate when the vehicle is turning left or right and detects a crossing pedestrian, if the following conditions are met:

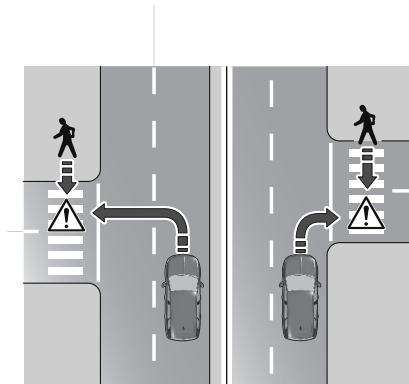

- the pedestrian is crossing in front of the vehicle
- the pedestrian can clearly be detected by the sensors

- the scenery is detectable by the sensors, e.g. brightness, contrast versus background
- the vehicle speed is between 8 km/h and 25 km/h

In addition, the system also reacts to cyclists.

Crossing manoeuvre

Vehicle crossing the path

The system may operate when a visible vehicle is crossing your path, if the following conditions are met:

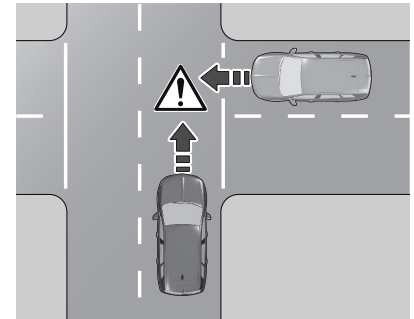



- the visible vehicle is crossing your path and can clearly be detected by the sensors
- the speed of the crossing vehicle is below 65 km/h

- the vehicle's speed is below 65 km/h

Automatic braking

Just before the imminent collision, this function automatically applies limited braking to reduce the impact speed of the collision or prohibit a crash.

If active emergency braking is applied,  flashes on the cluster.

If active emergency braking is finished,  flashes for a few seconds.

During this time, active emergency braking cannot be applied if there is a risk of a further collision.

Below a speed of 50 km/h, emergency automatic braking may slow down the vehicle to a complete stop. If the speed exceeds this limit, automatic braking reduces the speed. However, the driver must apply the brake to come to a complete stop.

If the vehicle comes to a complete stop, automatic braking is maintained for a certain time. **Keep the brake pedal depressed to prevent the vehicle from starting off again.**

Cruise control will be deactivated when an automatic braking occurs.

In some cases, the driver may wish to override the automatic braking provided by the active emergency braking system.

Firmly apply the accelerator pedal or firmly turn the steering wheel to override the automatic braking if the situation and surroundings permit.

Warning

Do not rely on the system to brake the vehicle. Active emergency braking will not brake automatically outside of its operating speed range.

Emergency brake assist

If the driver brakes, but not sufficiently to avoid a collision, this system will supplement the braking. This assistance will only be provided if the driver presses the brake pedal.

Emergency brake assist will automatically disengage when the brake pedal is released.

Operation conditions

Active emergency braking only works when:

- the brake system is operational

- Electronic Stability Control and Traction Control are activated
- the seat belts of the front seats and depending on version of the rear seats are fastened
- constant speed on unwinding roads

Active emergency braking is automatically deactivated in the following cases:

- a spare wheel with smaller diameter is detected
- a fault with the brake pedal switch or with the left or right brake light is detected
- a fault in the active emergency braking system, in the electronic or in the brake system is detected
- a severe crash, e.g., with airbag deployment was detected

System Limitations

The system performance may be degraded or not available in the following cases:

- sensor covered with snow, ice, slush, mud or dirt
- windscreen damaged or smeared, with blurred view or covered with foreign items, e.g. stickers

- damaged or deformed front bumper or front bumper covered with foreign items, e.g. stickers
- radar unit is out of its regular position resulting from an impact of the front bumper
- front camera out of its regular position
- automatic braking not available, e.g. brake discs cooling going on
- brake pedal continuously used for a long time, e.g. on a long downhill road
- winding or hilly roads
- system initialisation process after battery disconnection
- dazzling light, e.g. caused by the sun or artificial illumination is shining directly into the camera lens
- adverse environmental conditions, e.g. rain, fog or snow
- vehicle ahead creating road spray

After an impact or when damages are visible have the vehicle checked by a workshop.

The system performance may be affected by:

- Electronic Stability Control and Traction Control in progress

- vehicle battery voltage out of range
- wet road reflecting lights
- close vehicles ahead
- tractors, muddy vehicles or vehicles with a trailer
- banked roads
- poor lighting conditions
- sudden lighting changes
- vehicle modifications, e.g. tyres
- vehicle overloaded

The driver must not overload neither the load compartment nor the roof of the vehicle.

If a sensor is covered, a message is displayed indicating that the camera sensors must be cleaned.

If the system is temporarily affected and no driver action is required, no message is displayed.

Complete attention is always required while driving, and be ready to take action to avoid crashes.

We recommend to deactivate the system in the vehicle personalisation in the following cases:

- when towing a trailer or caravan

- when carrying long objects on roof bars or a roof rack
- when the vehicle is being towed
- when performing any maintenance with ignition on
- when the vehicle is fitted with snow chains
- when a spare wheel is fitted that is smaller than the other wheels
- before using an automatic car wash
- before placing the vehicle on a rolling road in a workshop
- if the windscreen has been damaged close to the camera
- If the front bumper has been damaged or deformed
- If the radar unit is out of its regular position resulting from an impact on the front bumper
- if the brake lights are not working

Fault



If the system does not work properly or is not available, e.g. during the initialisation, (ⓘ) illuminates on the cluster.

If the system has a fault,  illuminates on the cluster, a message is displayed and an audible signal is given. Consult a workshop.

 illuminates on the cluster accompanied by a message indicating that the sensors or the camera may be covered. Stop the vehicle and check, if

these needs to be cleaned. If  still illuminates after cleaning the camera, consult a workshop.

 may also illuminate if the infotainment system has an issue.

If  and  illuminate on the cluster after the engine has been switched off and then restarted, consult a workshop.

Vehicle messages ⇨ page 73

Automatic post collision braking

If an accident is detected, the vehicle requests automatic post collision braking. The goal of this function is to reduce the risk of further collisions if the driver does not react. The system operates on frontal, lateral and rear collision. The automatic post collision braking is not

operational if the capability of the vehicle to trigger and execute the automatic post collision braking is unavailable, as it can occur in destructive accidents or in other specific accident scenarios.



It is possible to override the automatic braking by pressing the accelerator pedal or the brake pedal.

System limitations

The system operates if the following conditions are fulfilled:

- airbags or seat belt pretensioners have been deployed by the collision
- braking system and electric functions remain continuously operational during and after collision
- driver has not depressed brake pedal or accelerator pedal

Fault

If automatic post collision braking is not available, the control indicator  or  illuminates continuously, a corresponding message appears on the cluster and a warning chime sounds.

Have the cause of the fault remedied by a workshop.

Forward Collision Warning (FCW)

The forward collision warning warns the driver if there is a risk of collision with the vehicle ahead, with a cyclist or a pedestrian.

Warning

Forward collision warning is just a warning system and does not apply the brakes. When approaching a vehicle ahead too rapidly, there may not be enough time to avoid a collision.

The driver accepts full responsibility for the appropriate following distance based on traffic, weather and visibility conditions.

The complete attention of the driver is always required while driving. The driver must always be ready to take action and apply the brakes.

Activation

Depending on the vehicle configuration and the detected objects, there are several operational speed ranges.

Forward collision warning operates up to 80 km/h when a pedestrian or a cyclist

has been detected. Forward collision warning operates from 8 km/h up to vehicle maximum speed when a vehicle has been detected.

Alerting the driver

The driver is warned by the following alerts:

- Level 1: A warning message is displayed on the cluster when the distance to the vehicle ahead gets too short.
- Level 2: A warning message is displayed on the cluster and a warning chime sounds, when a collision is imminent and immediate driver's action is required.
- Level 3: Depending on version, the vehicle may produce a short brake jerk to confirm the risk of collision. The immediate driver's action is required.

Warning

When approaching a vehicle ahead too rapidly, a level 2 alert may be displayed without a level 1 alert before.

Level 1 alerts depend on the alert sensitivity set. This alert type is only displayed in case of moving vehicles. At lower speed it is disabled.

Warning

The colour lighting of this symbol does not correspond to local traffic laws on following distance. The driver bears full responsibility for maintaining a safe following distance according to applicable traffic rules, weather and road conditions etc. at all times.

Selecting the alert sensitivity

Note

If the alert sensitivity setting with the longest distance is set, the system warns earlier. This increases safety, but also increases the amount of alerts if the legal safety distance is not kept. To reduce the number of alerts, select a shorter alert sensitivity setting.

Three alert sensitivities can be selected in the driver assistance systems menu.

Vehicle personalisation ⇒ page 71

The chosen setting will be memorised when the ignition has been switched off. The alert sensitivity will vary based on selected alert setting.

Deactivation

The system can only be deactivated by deactivating the active emergency

braking in the vehicle settings  on the Info Display.

Touchscreen and Info Display ⇒ page 68

System limitations

Forward collision warning is designed to warn on vehicles, cyclists and pedestrians, but may react also to other objects.

The system performance may be degraded or not available in the following cases:

- driving on winding or hilly roads
- driving during night-time
- weather limits visibility, such as fog, rain or snow
- the sensor in the windscreen is blocked by snow, ice, slush, mud, dirt etc.

- the windscreen is damaged or affected by foreign objects, e.g. stickers

Vehicle stability assistance system

ANTI-SLIP REGULATOR (ASR)

Anti-slip regulation (or traction control) optimises traction by using engine braking and by applying the brakes on the driving wheels to avoid one or more wheels spinning. It also enhances the vehicle's directional stability.

If there is a difference between the vehicle's trajectory and the path desired by the driver, the dynamic stability control system automatically uses engine braking and the brakes on one or more wheels to return the vehicle to the desired path, within the limits of the laws of physics.

These systems are activated automatically every time the vehicle is started.



These systems are activated in the event of a problem with grip or trajectory (confirmed by this warning lamp flashing on the instrument panel).

Fault



In the event of a fault, this warning lamp lights up on the instrument panel, accompanied by the display of a message and an audible signal.

Seek the assistance of a workshop.

Warning

ASR/DSC

These systems enhance safety during normal driving, but should not encourage the driver to take extra risks or drive at high speed.

It is in conditions of reduced grip (rain, snow, ice) that the risk of loss of grip increases. It is therefore important for your safety to keep these systems activated in all conditions, and particularly in difficult conditions.

Correct operation of these systems depends on compliance with the manufacturer's recommendations relating to the wheels (tyres and rims), braking and electronic components, as well as the assembly and repair procedures provided by dealers.

In order to ensure that these systems remain effective in wintry conditions, the use of snow tyres or all-season tyres is recommended. All four wheels must be fitted with tyres approved for your vehicle.

All tyre specifications are listed on the tyre/paint label. For more information on **Identification markings**, refer to the corresponding section.

ELECTRONIC STABILITY CONTROL (ESC)

Electronic Stability Control (ESC) improves driving stability when necessary, regardless of the type of road surface or tyre grip.

As soon as the vehicle starts to swerve (understeer / oversteer), engine output is reduced and the wheels are braked individually.

ESC operates in combination with the traction control system. It prevents the driven wheels from spinning.

The traction control system is a component of the ESC.

The traction control system improves driving stability when necessary, regardless of the type of road surface or tyre grip, by preventing the driven wheels from spinning.

As soon as the driven wheels starts to spin, engine output is reduced and the wheel spinning the most is braked individually. This considerably improves the driving stability of the vehicle on slippery road surfaces.

ESC and traction control system are operational after each engine start as soon as  extinguishes.

When ESC and traction control system operate,  flashes.

After reconnecting the vehicle battery, the system needs a recalibration by driving a short distance.

Warning

Do not let this special safety feature tempt you into taking risks when driving.

Adapt speed to the road conditions.

Control indicator ⇨ page 74

ESC and traction control system can be deactivated in the vehicle personalisation on the Info Display, accessing the menu with .

A status message appears on the cluster when ESC and traction control system are deactivated.

ESC and traction control system can be reactivated in the vehicle personalisation on the cluster, by applying the brake or in the case that the vehicle is driven faster than 50 km/h.

 on the cluster extinguishes when ESC and traction control system are reactivated. ESC and traction control

system are also reactivated the next time the ignition is switched on.

Fault

If there is a fault in the system,  illuminates continuously and a message appears on the cluster. The system is not operational.

Have the cause of the fault remedied by a workshop.

Side Blind Spot Alert (SBSA)

The side blind spot alert system detects and warns of vehicles approaching from the rear in neighbouring lanes up to 75 m or of another vehicle in the blind spot of the vehicle.

The system displays a visual alert in each exterior mirror when objects are detected that may not be visible in the interior and exterior mirrors.

Side blind spot alert uses two radar sensors located in the rear bumper on each side of the vehicle.

⚠ Warning

Damage or scratches on the vehicle surface near the radar sensors may affect the performance of the system. This can cause wrong warnings or the loss of warnings.

Seek the assistance of a workshop.

⚠ Warning

Side blind spot alert is only a lane changing aid and does not replace driver vision. Side blind spot alert does not detect:

- vehicles approaching very rapidly
- pedestrians or animals
- non-moving objects, e.g. stationary vehicles, street lights, road signs, etc.

Failure to use proper care when changing lanes may result in damage to the vehicle, injury or death. Always check the outside and rearview mirrors, glance over your shoulder and use the turn signal before changing lanes.

Activation

When the side blind spot alert is available, e.g. after the engine is

switched on, the LEDs in each exterior mirror are illuminated for approx. three seconds.

Info Display ⇨ page 68

Functionality

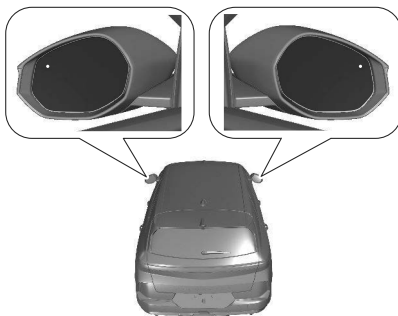

When the system detects a vehicle in the side blind zone while driving forwards, an LED will illuminate in the relevant exterior mirror. If the turn lights of the relevant side are activated, the LED will flash.

The LED comes on immediately when being passed.

The LED comes on after a delay when passing another vehicle slowly.

Operation conditions

The following conditions must be fulfilled for proper operation:

- all vehicles are moving in the same direction and in adjacent lanes
- passing a vehicle with a speed difference of less than 15 km/h
- no plug is connected to the power outlet of the trailer hitch
- the sensors are not covered by mud, ice or snow
- LEDs in the door mirrors and the rear radars are not covered with stickers or other objects
- the traffic flow is normal
- driving on a straight or slightly curved road

No alert will be given in the following situations:

- in the presence of non-moving objects, e.g. parked vehicles, barriers, street lights, road signs
- in very dense traffic, when moving vehicles might be confused with a stationary object
- with vehicles moving in the opposite direction
- driving on a winding road or a sharp corner

- when passing or being passed by a very long vehicle, e.g. lorry, coach, which is at the same time detected at the rear in the blind spot angle and present in the driver's forward field of vision
- when passing too quickly

The function will not work properly due to adverse weather conditions such as heavy rain, damage of the surface near the radar sensor or when the sensors are covered with mud / dirt from the road.

Deactivation

The system can be deactivated in the vehicle personalisation on the Info

Display, accessing the menu with .

The state of the system is not memorised when switching off the ignition.

The system is switched off automatically when attaching a trailer or bike carrier to the trailer hitch.

Fault

In the event of a fault,  illuminates on the Info Display, accompanied by a display message.

Seek the assistance of a workshop.

Lane Departure Warning (LDW)

The lane departure warning system supports the driver to avoid unintended lane departure. The front camera observes road edges, as well as the lane markings between which the vehicle is driving. If the vehicle crosses a road edge or a lane marking, the system warns the driver.

Unintended lane departure is not assumed by the system when the turn lights are operated and during few seconds after turn lights have been switched off.

No warning will be issued with a dynamic driving, i.e. pressure on the brake or accelerator pedal or heavy steering.

When the system recognises an unintended lane departure, the control indicator  rapidly flashes yellow.

Operating conditions

For correct operation of the system, the following preconditions must be fulfilled:

- vehicle speed must be between approx. 65 km/h and 180 km/h
- the turn lights are not activated

- no dynamic driving, i.e. pressure on the brake or accelerator pedal

- lane boundaries can be clearly detected by the system

- the vehicle is not driven in a tight corner

- no system fault is present which prevents corrections

Deactivate the system when the vehicle is being towed.



Warning

This system is a driving aid that cannot, in any circumstances, replace the need for vigilance on the part of the driver.

Activation

Depending on version, the system is automatically active by default every time the engine is started, even if it was deactivated during the last ignition cycle.

For further information see ⇨ page 137

If the system is activated,  on the cluster is not illuminated. The system can be activated in the vehicle personalisation on the Info Display, accessing the menu with .

Deactivation

The system can be deactivated in the vehicle personalisation on the Info

Display, accessing the menu with .

System limitations

The system performance may be affected by:

- camera covered by snow, ice, slush, mud, dirt, or affected by windscreen damage or foreign items, e.g. stickers
- close vehicles ahead
- banked roads
- winding or hilly roads
- poor lighting conditions
- sudden lighting changes
- dazzling light, e.g. caused by the sun or artificial illumination is shining directly into the camera lens
- adverse environmental conditions, e.g. heavy rain, fog or snow
- vehicle modifications, e.g. tyres
- roads with poor lane markings

Fault

In the event of a fault,  illuminates on the cluster, accompanied by a display

message and a warning chime. Seek the assistance of a workshop.

If a sensor is covered,  illuminates on the cluster and a message is displayed indicating that the sensors need to be cleaned.

Lane Keeping Assist (LKA)

Lane keeping assist supports the driver to avoid unintended leaving of the lane. The front camera observes road edges, as well as the lane markings between which the vehicle is driving.

If the vehicle approaches a road edge or a lane marking, the steering wheel is gently turned so that the vehicle turns back into the lane.

The driver will notice a turning movement of the steering wheel.

Turn the steering wheel in same direction, if the system does not steer sufficiently. Turn the steering wheel gently into opposite direction, if a lane change is intended.

When the system steers to correct the trajectory of the vehicle,  flashes yellow on the cluster. Lane keeping

assist does not continuously steer the vehicle.

Unintended lane departure is not assumed by the system when the turn lights are operated and during few seconds after the turn lights have been switched off.

The system will inform the driver with a message and a chime if there is an ongoing correction for more than ten seconds. If the driver is still unable to keep the vehicle in the lane, the correction interrupts after a short time.

When hands-off driving is detected during a correction a warning message appears on the cluster, accompanied by a warning chime. Every further hands-off detection prolongs the warning chime duration.

A lane departure warning on the cluster alerts when the system cannot hold the vehicle within the lane and immediate driver's action is required.

Note

The system might be inactive if it detects lanes that are too narrow, too wide or too curved.

For correct operation of the system, the following preconditions must be fulfilled:

- vehicle speed must be between approx. 65 km/h and 180 km/h
- the turn lights are not activated
- the electronic stability control is activated and not in operation
- no plug is connected to the power outlet of the trailer hitch
- no dynamic driving, i.e. pressure on the brake or accelerator pedal
- lane boundaries can be clearly detected by the system
- no temporary spare wheel is used
- the vehicle is not driven in a tight corner
- no system fault is present that prevents corrections



Depending on version, only lane departure warning system is active, when a system fault is present, a spare wheel is used, Electronic Stability Control is not activated or e.g. a trailer is attached.

Deactivate the system when the vehicle is being towed.

Activation

Depending on version, the system is automatically active by default every time the engine is started, even if it was deactivated during the last ignition cycle.

For further information see: → page 137

If the system is activated,  on the cluster is not illuminated. The system can be activated in the vehicle personalisation on the Info Display, accessing the menu with .

Deactivation

The system can be deactivated in the vehicle personalisation on the Info Display, accessing the menu with .

The state of the system is memorised when switching off the ignition.

Hand-off

When hands-off driving is detected during a correction within a rolling interval of 180 seconds, the system intervenes:

Intervention 1:  flashes until the end of the intervention.

Intervention 2:  flashes and a warning chime sounds until the end of intervention but for at least one second.

Further interventions:  flashes continuously and the warning chime sounds 10 seconds longer than the previous chime.

A lane departure warning on the cluster alerts when the system cannot hold the vehicle within the lane and immediate driver's action is required.

System limitations



The system performance may be affected by:

- camera covered by snow, ice, slush, mud, dirt, or affected by windscreen damage or foreign items, e.g. stickers
- heavy or unequally distributed loading
- close vehicles ahead
- banked roads
- winding or hilly roads
- poor lighting conditions
- sudden lighting changes
- dazzling light, e.g. caused by the sun or artificial illumination is shining directly into the camera lens

- adverse environmental conditions, e.g. heavy rain, fog or snow
- vehicle modifications, e.g. tyres
- wrong tyre pressure
- roads with poor lane markings

Fault

In the event of a fault,  illuminates on the cluster, a message is displayed and an audible signal is given. Consult a workshop.

 illuminates on the cluster accompanied by a message indicating that the front camera may be covered. Stop the vehicle and check, if the camera needs to be cleaned. If  still illuminates after cleaning the camera, consult a workshop.

Semi-automatic lane changing

(with Intellidrive 2.0)

This system assists the driver in changing lanes.

To do this, it uses the camera located at the top of the windscreen, the radar

located at the front and the four angle radars fitted in the bumpers.

Warning

The steering wheel is equipped with a hands-on detection system to avoid distraction on the part of the driver.

For more information on the **Hands-on detection**, refer to the corresponding section.

Warning

The system cannot in any circumstances replace the need for vigilance on the part of the driver. The driver remains responsible for their driving by monitoring their surroundings and keeping their hands on the steering wheel.

The driver must act promptly if they believe that the traffic conditions or the state of the road surface require their intervention, by moving the steering wheel to temporarily suspend system operation.

Any intervention on the brake pedal or the accelerator pedal that causes the adaptive cruise control to be paused or suspended will also cause the system to deactivate.

Selecting the system

Two options:

- Either when the vehicle is already driving on an eligible road, the driver selects the system by activating the Drive Assist Plus 2.0 system.
- Or when the driver is already using Drive Assist Plus, the vehicle prompts to select the system upon arriving at

an eligible road by pressing the **OK** button.

Operating conditions

- Eligible roads: roads with separate carriageways with prohibited access for pedestrians and cyclists.
- The line separating the lanes must be clear enough to be identified by the system.
- The position and speed of other vehicles must enable the system to safely change lanes.
- Drive Assist Plus 2.0 activated.
- Lane positioning assist activated.
- Vehicle speed between 65 and 180 km/h.

Activation/deactivation

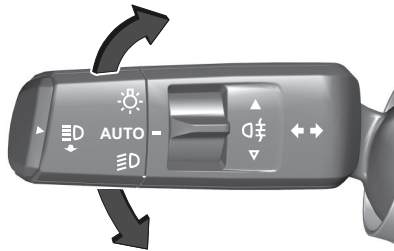

- Activate the direction indicator on the side corresponding to the lane change, whether or not passing the resistance point of the lighting control stalk.
- The driver can regain control of the vehicle at any time:
 - by deactivating the direction indicator if the vehicle has not yet crossed the line.
 - by firmly holding the steering wheel.
 - by acting on the pedals.

For more information on the **Direction indicators**, refer to the corresponding section.

The message **"Stay attentive"** is displayed as a reminder that the driver is still responsible for the manoeuvre.



The system then proceeds with the vehicle's lane change.

Once the manoeuvre has been carried out, the system is automatically deactivated and the lane positioning assist takes over.

If the direction indicator has been set beyond the point of resistance, the driver must pull it back.

Tip

The driver must hold the steering wheel correctly.

As soon as the semi-automatic lane change begins, the system directs the vehicle to the target lane by small actions on the steering to position it in the destination lane.

You can feel the steering wheel moving.

Interrupting the lane change

It is possible that while changing lane, the necessary conditions for the operation of the system may no longer be met.

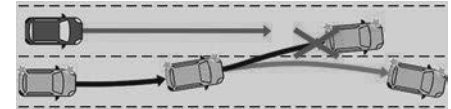

If this occurs before one of the wheels has crossed the line separating the two lanes, the system automatically returns the vehicle to its original lane (confirmed by the display of a manoeuvre cancellation message on the instrument panel or in the HUD and an audible

signal). The system is then automatically deactivated.

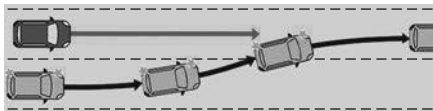

If this occurs when the lane change has started, the system prompts the driver to immediately retake control of the vehicle (confirmed by the display of a message on the instrument panel or in the HUD and an audible signal), and the system is automatically deactivated.

Refused lane change request

When operating the direction indicator, if the necessary conditions are not met, the lines appear in orange on the instrument panel or in the HUD.

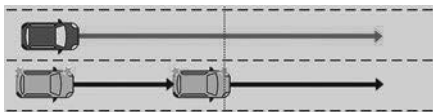

The system keeps the vehicle in the original lane. The system is deactivated and the semi-automatic lane change is not carried out.

Lane positioning assist (LPA)

⚠ Warning

The system assists the driver in managing the steering, acceleration and braking within the limits of the laws of physics and the capabilities of the vehicle. Some road infrastructure elements or vehicles present on the road may not be properly seen or may be poorly interpreted by the camera, which may lead to an unexpected change in direction, a lack of steering correction and/or inappropriate management of the acceleration or braking.

Lane positioning assist is an enhancement of the lane keep assist system.

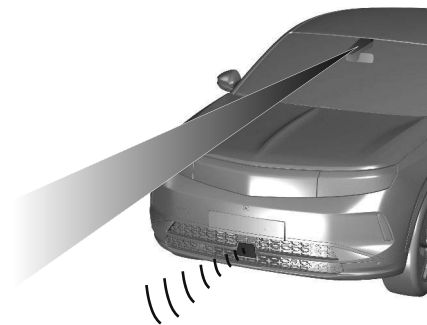

The activated system observes the lane markings by using the camera located at the top of the windscreen. It steers the vehicle inside the detected lane. The driver will notice a turning movement of the steering wheel.

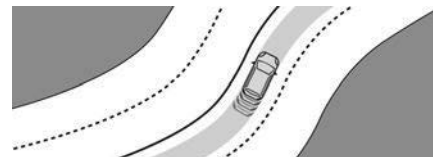

Thus, the current position of the vehicle within the lane is kept.

This position is not necessarily the centre of the lane.

In the case that the vehicle is driving at the outer edge of the lane, the system corrects the trajectory smoothly towards the centre of the currently driven lane when a determined speed has been exceeded.

Again, the driver will notice a turning movement of the steering wheel.

When the vehicle is steered by the system,  illuminates green on the cluster. However, the control of the vehicle can be taken over at any time by the driver.

Therefore, the driver needs to apply some additional force when turning the steering wheel.

If the system detects that the driver is not holding the wheel firmly enough, it triggers a series of gradual alerts.

If the interruption takes too long, the system will be deactivated.  extinguishes on the cluster.

The system has to be reactivated again by the driver. Lane positioning assist operates only in combination with adaptive cruise control. ⇨

Required preconditions

- Drive assist must be activated.

- The driver must hold the steering wheel.
- The turn lights are not activated.
- The Electronic Stability Control is activated and not in operation.
- No plug is connected to the power outlet of the trailer hitch.
- No dynamic driving is detected, i.e. pressure on the brake or accelerator pedal.
- Lane boundaries can be clearly detected by the system.
- No temporary spare wheel is used.
- The vehicle is not driven in a tight corner.
- No system fault is present which prevents corrections.

Activation/deactivation



Activation

Press  successively until the Drive Assist mode is selected.

The Drive Assist screen is displayed on the cluster.

Info Display ⇨ page 68

Deactivation

Press  repeatedly until the mode to switch off assistance is selected.

Pausing / suspending the system

Note

When using semi-automated lane change, setting the turn lights starts a semi-automated lane change manoeuvre.

Advanced lane keep assist may be paused or suspended in the following situations:

- The Electronic Stability Control is in operation or it has been deactivated.
- At least one of the lane markings is not detected by the system for several seconds. The system will be reactivated once the operating conditions are regained.
- The driver activates the turn lights and turns the steering wheel.
- Driving outside the lane limits.
- The steering wheel is held too tight or moved too dynamically.
- The brake pedal or the accelerator pedal is applied.
- The adaptive cruise control is paused.
- The road is too narrow or wide.
- The lateral acceleration in curves is too high

System limitations

The system performance may be affected by:

- camera covered by snow, ice, slush, mud, dirt, or affected by windscreen damage or foreign items, e.g. stickers
- close vehicles ahead
- banked roads
- winding or hilly roads
- poor lighting conditions
- sudden lighting changes
- dazzling light, e.g. caused by the sun or artificial illumination is shining directly into the camera lens
- adverse environmental conditions, e.g. heavy rain, fog or snow
- vehicle modifications, e.g. tyres
- roads with poor lane markings

A warning message may appear when the vehicle is travelling in a long straight lane on a smooth road surface even if the driver is holding the steering wheel properly.

Deactivate the system if the system is disturbed by tar marks, shadows, road cracks, temporary or construction lane markings, or other road imperfections.

Warning

Always keep your attention on the road and maintain proper vehicle position within the lane, otherwise vehicle damage, injury or death could occur.

The system may not keep the vehicle in the lane or give an alert, even if a lane marking is detected.



The steering of the system may not be sufficient to avoid a lane departure.

The system may not detect hands-off driving due to external influences (road condition and surface, weather etc.).

The driver has full responsibility to control the vehicle and is always required to keep the hands on the steering wheel while driving.

Using the system on slippery roads could cause loss of control of the vehicle and a crash. Switch the system off.

Fault

In the event of a fault,  and  illuminate on the cluster or the HUD, accompanied by a message and a warning chime. Seek the assistance of a workshop.

Parking assist

General information

The rear system is deactivated when a plug is connected to the power outlet of the trailer hitch.

Warning

The driver bears full responsibility for the parking manoeuvre.

Always check the surrounding area when driving backwards or forwards while using parking assist system.

Front-rear parking assist

The front-rear parking assist measures the distance between the vehicle and obstacles in front and behind the vehicle. It informs and warns the driver by giving audible signals and display indication.

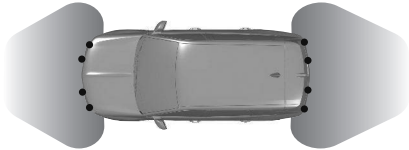

The system operates with ultrasonic parking sensors in the rear and front bumper.

Activation

The system can be activated in the vehicle personalisation on the Info

Display, accessing the menu with .

When a forward gear has been engaged, the front parking assist is activated, as soon as an obstacle is detected in the front and the speed of the vehicle is below 10 km/h.

When the reverse gear has been engaged, the rear parking assist and the front parking assist are activated.

After engaging the reverse gear, an audible signal is given from the rear speakers and a display indication will be shown. If no audible signal is given, the display indication is not shown or a warning message appears, the system has a failure.

Deactivation



The system can be deactivated in the vehicle personalisation on the Info

Display, accessing the menu with .

The rear parking assist is switched off when reverse gear is disengaged.

Indication

As soon as an obstacle gets closer to the vehicle, an audible signal is given and

  may flash. The interval between the sounds becomes shorter as the vehicle gets closer to that obstacle. When the distance is less than approx. 30 cm, the sound is continuous.

Audible signals are given via front or rear loudspeakers depending on which detected obstacle is nearest to the vehicle.

No audible signals are given:

- if the vehicle stops for more than three seconds and if the obstacle is not in the red (closest) zone
- if the automatic transmission is in **P** position
- if no further obstacles are detected

An audible signal is not given if the sound has been muted or if the display of the rear view camera indicated on the Info Display has been switched off.

Additionally, the distance to obstacles is displayed by changing distance lines in the central screen ⇨ page 68

When the obstacle is very close,  for danger is displayed.



Muting the sound / closing the display indication

If the audible signal is muted or the display of the rear view camera is closed and an obstacle gets closer, only the ^{P)}  flashes.

The muting will be disabled as soon as the vehicle exceeds 10 km/h. The sound will be active again when the speed is below 10 km/h.

System limitations

In the event of a fault or if the system does not work temporarily, e.g. because of high external noise level or

other interference factors,  and ^{P)}  illuminate on the cluster. A message is displayed and a warning chime sounds.

Note

Make sure that the front number plate is properly mounted, vertically and horizontally centred and the sensors are firmly in place. The performance of the parking assist will be reduced if the licence plate is bent or a licence plate support is used.

Warning

Under certain circumstances, various reflective surfaces on objects or clothing as well as external noise sources may cause the system to fail to detect obstacles.

Special attention must be paid to low obstacles, which can damage the lower part of the bumper.

CAUTION

In the case of a severe failure of the vehicle with the need to stop the vehicle, the system is deactivated.

In the case of a gearbox failure, the parking assist system is not active, when reverse gear is engaged.

In the case of a sound of loudspeaker failure, the audible signals may not be given.

The performance of the system can be reduced when the sensors are covered, e.g. by ice or snow.

If a sensor is covered, a message is displayed indicating that the sensors need to be cleaned.

The performance of the parking assist system may be limited or the functionality may not be available at all

if  illuminates or if the image shown on the Information Display is frozen or if the screen is black.

CAUTION

The performance of the parking assist system can be reduced due to heavy loading.

Special conditions apply if there are taller vehicles in the vicinity (e.g. off-road vehicles, mini vans, vans). Object identification and correct distance indication in the upper part of these vehicles cannot be guaranteed.

Objects with a very small reflection cross-section, e.g. objects of narrow size or soft materials, may not be detected by the system.

Parking assist systems do not detect objects outside the detection range, e.g. below the bumper or underneath the vehicle.

During a reverse parking manoeuvre, the system does not consider a mounted coupling ball bar. The driver must consider this additional length.

Note

It is possible that the sensor detects a non-existing object caused by echo disturbance from external acoustic noise or mechanical misalignments (sporadic false warnings may occur).

Make sure that the front number plate is properly mounted (not bent and no gaps to the bumper on the left or right side) and the sensors are firmly in place. The performance of the parking assist may be reduced if the licence plate is bent or a licence plate support is used.

Low curbs and surface irregularities, e.g. on construction zones, are not detected by the system. The driver accepts responsibility.

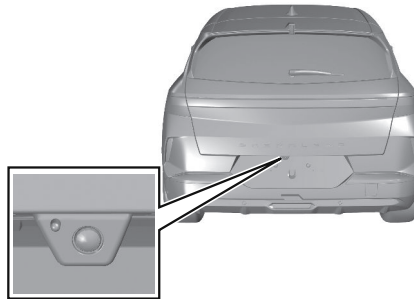
Rear View Camera (RVC)

The rear view camera assists the driver when reversing by displaying a view of the area behind the vehicle. It allows views of the vehicle's surroundings to be

displayed as a nearly 180° picture on the Info Display, like a bird's eye view.

Warning

The rear view camera does not replace driver vision. Note that objects that are outside the camera's field of view and the parking assist sensors, e.g. below the bumper or underneath the vehicle, are not displayed.

Do not reverse or park the vehicle using only the rear view camera.

Always check the surrounding of the vehicle before and during driving.

The system uses:

- rear view camera, mounted above the rear number plate
- ultrasonic parking sensors in the rear bumper

The screen on the Info Display is divided into three parts:

- On the right side, there is a view from above the vehicle.
- The middle part consists of a contextual view.
- The left side consists of the view selection as well as the settings menu.

The parking sensors complete the information on the view from above the vehicle.

The area displayed by the rear view camera is limited. Displayed images may be further or closer than they appear.

The system automatically selects the best view to display according to the information from the parking sensors. The state of the system is not kept in memory when the ignition is switched off.

Activation

The rear view camera is activated when the reverse gear is engaged.

It can also be activated manually in the Driver Assist menu.

Functionality

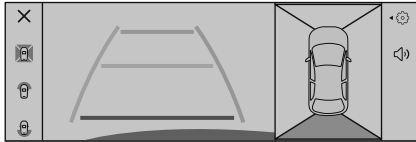

Different views can be selected in the left part of the display.

Change the type of view at any time during a manoeuvre by selecting the required view from the view selection in the left part of the Info Display:

- Standard view
- 180° view

The display is immediately updated with the type of view selected.

Using the camera, the vehicle's close surroundings are recorded during low speed manoeuvres. An image from above the vehicle in its close surroundings is created in real time (on the side of the screen), as the vehicle progresses.

This view makes it easier to align the vehicle when parking and to perceive nearby obstacles. It is automatically deleted if the vehicle remains stationary for too long.

Standard view

The area behind the vehicle is displayed in the screen. The vertical lines represent the width of the vehicle with mirrors unfolded. The direction of the lines changes with the steering angle.

The first horizontal line represents a distance of about 30 cm beyond the edge of vehicle's rear bumper. The upper horizontal lines represent distances of about 1 m and 2 m.

This view is displayed automatically or can be chosen from the view selection.

Trajectory lane of the vehicle is shown in accordance with the steering angle.

180° view

The 180° view facilitates reversing out of a parking bay, making it possible to see approaching vehicles, pedestrians and cyclists.

This view is not recommended for carrying out a complete manoeuvre.

Zoom view

The rear view camera records the vehicle's surroundings during the manoeuvre in order to reconstruct a view from above the rear or the front of the vehicle in its near surroundings.

An image from above the vehicle in its close surroundings is created as the vehicle progresses. Thus, the vehicle can be manoeuvred around nearby obstacles. Zoom view cannot be manually selected. It is automatically activated if the distance between the

vehicle and the obstacle is approx. 60-80 cm.

The automatic display of the zoom view can be disabled on the Info Display:

Press  below the Info Display and select Panoramic camera.

Press  Activate View Adaptation.

The setting is memorised when the ignition is switched off.

Settings menu

The settings menu allows to adjust the following settings:

- volume of the audible signal

Deactivation

The rear view camera is deactivated when:

- driving faster than 12 km/h in a forward direction
- by pressing the icon X in the left upper corner on the Info Display.

System limitations

CAUTION

For optimal operation of the system, it is important to keep the lens of the camera, which is located between the number plate lights, clean at all times. The rear view camera can be cleaned by a washer nozzle which is automatically activated when the rear window washer is operating.

To wipe away water drops from the lens, use a soft cloth.

Do not clean the lens with a steam-jet or high-pressure jet cleaner.

The rear view camera may not operate properly when:

- Surroundings are dark
- sun or beam of headlights is shining directly into camera lenses
- weather limits visibility, such as fog, rain or snow
- camera lenses blocked by snow, ice, slush, mud, dirt. The rear camera can be cleaned by activating the rear window washer.

Rear window wiper and washer ⇒
page 43

- the tailgate will be opened
- vehicle is electrically connected to a trailer, bicycle carrier, etc.
- vehicle had a rear end accident
- extreme temperature changes

Panoramic view system

This system allows views of the vehicle's surroundings to be displayed as a full 360° picture on the Info Display, like a bird's eye view.

⚠ Warning

The panoramic view system does not replace driver vision. It will not display children, pedestrians, cyclists, crossing traffic, animals or any other objects outside of the camera view area, e. g. below the bumper or underneath the vehicle.

Do not drive or park the vehicle using only the panoramic view system.

Always check the surrounding of the vehicle before and during driving.

Displayed images may be further or closer than they appear. The area displayed is limited and objects that are close to either edge of the bumper or under the bumper are not displayed on the screen.

Depending on the load of the vehicle, the inclination of the vehicle may be changed including the view of the camera.

The system uses:

- rear camera above the rear number plate



- front camera
- two side cameras in the exterior mirrors
- ultrasonic parking sensors in the bumpers

Visualisation on the Info Display



The screen is divided into four areas, from left to right:

- selectable views: standard, panoramic front, panoramic rear
- view visualisation
- top view including four selectable side views (in standard view only)
- settings

The parking sensors complete the information on the top view.

Activation

The panoramic view system is activated by:

- engaging the reverse gear when the engine is switched on

- manual activation on the Info Display when the vehicle speed is below 16 km/h

Info Display ⇨ page 68

Functionality

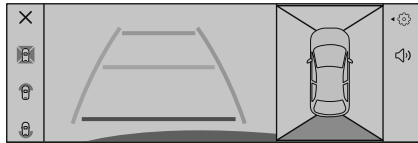

Different views can be selected in the left part of the display. Change the type of view at any time during a manoeuvre by selecting a view from the left side:

- standard view
- panoramic view
- side view

The display is immediately updated with the type of view selected.

By default, the zoom view is enabled.

This setting can be changed in the settings of the panoramic view system on the Info Display.

The state of the system is kept in memory when the ignition is switched off.

Standard view

The standard view consists of a rear view and a front view.

Rear view

The area behind the vehicle is displayed in the screen. The vertical lines represent the width of the vehicle with mirrors unfolded. The direction of the lines changes with the steering angle.

The first horizontal line represents a distance of about 30 cm beyond the edge of vehicle's rear bumper. The upper horizontal lines represent distances of about 1 m and 2 m.

This view is available in auto mode or can be chosen from the left side of the screen.

Front view

The area in front the vehicle is displayed in the screen. The vertical lines represent the width of the vehicle with mirrors unfolded. The direction of the lines changes with the steering angle.

The first horizontal line represents a distance of about 30 cm beyond the edge of vehicle's front bumper. The upper horizontal lines represent distances of about 1 m and 2 m.

This view is displayed automatically or can be chosen from the left side of the screen.

Panoramic view

The panoramic view facilitates leaving a parking bay, making it possible to see approaching vehicles, pedestrians and cyclists. This view is not recommended for carrying out a complete manoeuvre. This view can only be selected from the left side of the screen.

Side view

This view makes it possible to view the surroundings, e.g. a pavement, a low wall, nearby parked vehicles etc. on the left-hand or right-hand side of the vehicle.

Select the standard view and touch the required side of the vehicle. The selected side is highlighted and the side view is displayed.

Zoom view

The zoom view cannot be selected. It is only displayed if the distance between

the vehicle and the obstacle is less than 60-80 cm.

The zoom provides a view from above the rear or the front of the vehicle in its near surroundings. Thus, the vehicle can be manoeuvred around nearby obstacles.

The automatic display of the zoom view can be disabled on the Info Display:

Press  below the Info Display and select **Panoramic camera**.

Press .

Activate **View Adaptation**.

The setting is memorised when the ignition is switched off.

Settings

The following settings can be adjusted:

- volume of the audible signal

Deactivation

Panoramic view system is deactivated when:

- driving faster than 16 km/h in forward gear
- by pressing the icon **X** in the left upper corner of the touchscreen

System limitations

CAUTION

For optimal operation of the system, it is important to keep the lenses of all cameras clean at all times. For the rear view camera, there is a washer nozzle which will be activated when the rear window washer is operating.

If manually cleaning the lenses of the cameras, rinse the lenses with water and wipe with a soft cloth.

Do not clean the lenses with a steam-jet or high-pressure jet cleaner.

The panoramic view system may not operate properly when:

- The surroundings are dark.
- The sun or the beam of headlights is shining directly into the camera lenses.
- Weather limits visibility, such as fog, rain, or snow.
- The camera lenses are blocked by snow, ice, slush, mud, dirt. The rear camera can be cleaned by activating the rear window washer.

Rear window wiper and washer ⇨
page 43

- The vehicle is towing an electrically connected trailer, bicycle carrier, etc.
- The vehicle has had an accident. Contact a workshop.
- There are extreme temperature changes.

CAUTION

It is very important that any repair to the panoramic view system is performed accurately according to Vauxhall specifications. Otherwise, the system may not work properly and there is a risk of unexpected behaviour and / or messages from the system.

Rear cross traffic alert

CAUTION

The driver must monitor the surroundings before and during the whole manoeuvre. Drive slowly and carefully in reverse gear in case of reduced or no visibility.

It is possible that warnings are not given, are given too late or seem unjustified. Be prepared to react at any time to avoid an accident.

Note

If repainting the rear bumper, consult a qualified workshop since certain types of paint could interfere with the operation of the radar units.

Additional to the side blind spot alert ⇒ page 145, rear cross traffic alert warns of cross traffic from left or right side when driving rearwards at a speed up to 10 km/h. It warns of approaching objects such as vehicles, trucks, pedestrians, cyclists and motorcycles.

To monitor the area left and right behind the vehicle, the system uses two radar sensors located in the rear bumper on each side of the vehicle.

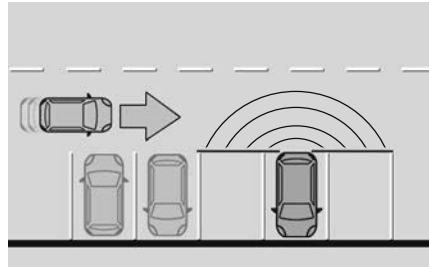

Activation / deactivation

The system can be activated/deactivated in the vehicle personalisation on the cluster, accessing the menu with .

Detection zone

The system detects obstacles moving at speeds faster than 3 km/h and at a maximum distance of 40 m.

Functionality

If an approaching obstacle is detected while the vehicle is in reverse gear,  or  flashes on the cluster. In addition, an audible signal is given when the vehicle is moving backwards.

System limitations

The system may not operate properly in the following situations:

- towing trailer
- using a bicycle carrier on a towing device
- extreme temperature changes

- rear bumper damaged
- accumulation or projection of external elements (e.g. mud, ice, snow), application of stickers.

Fault

In the event of a fault,  appears on the cluster, accompanied by a message and a warning chime. Seek the assistance of a workshop.

Driver drowsiness detection

The driver alert system monitors the driving time and the vigilance of the driver. Monitoring the vigilance of the driver is based on the trajectory variations of the vehicle compared to the lane markings.

The system cannot replace the need for vigilance on the part of the driver.

Taking a break is recommended as soon as feeling tired or at least every two hours. Do not drive when feeling tired.

Activation or deactivation

The system can be activated or deactivated in the vehicle personalisation
⇒ page 68.

When the system is deactivated  may illuminate on the cluster.

The system is automatically activated when ignition is switched on.

Driving time alert

The driver gets notified by a pop-up reminder symbol  on the cluster simultaneously with an acoustic alert if the driver has not taken a break after two hours of driving at a speed above 65 km/h. The alert is repeated hourly until the vehicle is stopped, no matter how vehicle speed evolves.

The counting of driving time alert is reset when the ignition has been switched off for a few minutes, or the driver's seat belt has been unfastened and the driver's door has been opened.

Driver drowsiness detection

The system monitors the driver's level of vigilance at speeds above 65 km/h. A camera at the top of the windscreen

detects variations in trajectory compared to the lane markings.

The system may perform a learning procedure for up to 30 minutes after the start of the monitoring. During this period, the driver's individual driving behaviour is analysed and no alert is given.

If the trajectory of the vehicle suggests a certain level of drowsiness or inattention by the driver, the system triggers the first level of alert.

The driver is notified by a message and an audible signal is given.

After three first level alerts, the system triggers a new alert with a message, accompanied by a more pronounced audible signal.

In certain driving conditions such as poor road surface or strong winds etc., the system may give alerts independent of the driver's level of vigilance.



The driver drowsiness detection is reinitialised in the following situations:

- the ignition has been switched off for a few minutes
- the speed remains below 65 km/h for a few minutes

- the driver's seat belt has been unfastened and the driver's door has been opened

System limitations

In the following situations, the system may not operate properly or even not operate at all:

- poor visibility caused by inadequate lighting of the roadway, falling snow, heavy rain, dense fog etc.
- dazzle caused by headlamps of oncoming vehicles, low sun, reflections on damp roads, leaving a tunnel, alternating shade and light etc.
- no lane markings detected or multiple lane markings due to roadworks
- close vehicles ahead
- winding roads or narrow roads
- advanced lane keep assist is active
- covered camera by snow, ice, slush, mud, dirt, or affected by windscreen damage or foreign items, e.g. stickers,  may appear on the cluster centre, accompanied by a message
- in the event of a system fault,  may appear on the cluster, accompanied by a message and a warning chime.

Speed limiter

The speed limiter prevents the vehicle from exceeding a pre-set maximum speed. The maximum speed can be set at speeds between 30 km/h and 180 km/h. The driver can accelerate the vehicle up to the pre-set speed. Deviations from the limited speed may occur when driving downhill. The pre-set speed can be exceeded temporarily by pressing the accelerator pedal firmly. The status and pre-set speed limit are displayed on the cluster.

Switching on the system

Press  once to activate the Cruise Control function.

Press Limit twice to activate speed limiter.

Activation of the functionality

Setting speed by the driver



Press  once to activate the Cruise Control function.



The preset speed can be changed by pressing + to increase or - to decrease the speed. A short press changes speed

by 1 km/h, a long press changes speed by 5 km/h.

Press + or - to activate.

Press  to activate within the same ignition cycle.

Exceeding the speed limit

In the event of an emergency, it is possible to exceed the speed limit by depressing the accelerator pedal firmly to the final point. In this case, the pre-set speed value flashes.

Release the accelerator pedal and the speed limiter function is reactivated once a speed lower than the limit speed is obtained.

Deactivation of the functionality

Press , speed limiter is in pause mode and a message is displayed.

The vehicle is driven without speed limiter.

Speed limiter is deactivated, but not switched off. Last stored speed remains in memory for later speed resume.

Resume limit speed

Press **II ▷** or **+ / -**

Switching off the system

Press **II ▷**, the speed limiter mode is deselected and the speed limit indication extinguishes.

Fault

In the event of a speed limiter fault, the speed is cleared resulting in flashing of the dashes.

Have the system checked by a workshop.

Adaptive cruise control

The adaptive cruise control can store and maintain speeds above 40 km/h. In addition, it maintains a certain following distance to the vehicle ahead.

For vehicles with manual transmission, any gear has to be selected. For vehicles with automatic transmission, position **D** or the second or a higher gear in position **M** must be selected.

Deviations from the stored speeds may occur when driving uphill or downhill.

The system maintains the vehicle speed at the pre-set speed by the driver, without any action on the accelerator pedal.

The pre-set speed can be exceeded temporarily by pressing the accelerator pedal firmly.

The status and pre-set speed is displayed on the cluster.

Do not use the adaptive cruise control if it is not advisable to maintain a constant speed.

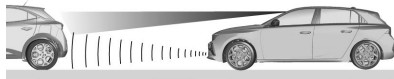

The adaptive cruise control automatically decelerates the vehicle when approaching a slower moving vehicle. It uses a camera located at the top of the windscreen and a radar unit located in the front bumper to detect the vehicles ahead. It then adjusts the vehicle speed to follow the vehicle ahead at the selected following distance. The vehicle speed increases or decreases to follow the vehicle ahead, but will not exceed the set speed. It may apply limited braking with activated brake lights.

If the vehicle ahead accelerates or changes lane, the adaptive cruise control progressively accelerates the vehicle to return to the stored set speed. If the driver operates the turn lights to overtake a slower vehicle, the adaptive cruise control allows the vehicle to temporarily approach the vehicle ahead to help passing it. However, the set speed will never be exceeded.

If the vehicle ahead is moving too slowly and the selected following distance cannot be maintained anymore, a warning chime is given and a message is displayed. The message prompts the driver to take back control of the vehicle. The system can brake the vehicle to a full stop. Depending on the version, the system can automatically accelerate the vehicle after a full stop.

Warning

The brake lamps come on if the vehicle is slowed down by active emergency braking. If the brake lights fail, the system does not operate.

Switching on the system

Press  and make sure the **Drive Assist** is activated in the Info Display.



Press  successively until the adaptive cruise control mode is selected. The adaptive cruise control screen is displayed. The system is still not activated.

Operation conditions

The system can be activated if the following conditions are met:

- Activation is possible at a vehicle speed of above 30 km/h but the system works down to 0 km/h
- driver's door closed
- driver's seat belt fastened
- D selected or second or higher gear engaged
- parking brake released

- brake pedal depressed if vehicle stationary.

Activation of the functionality

If all operating conditions are met, **OK?** is displayed.

Press **OK** to store the current vehicle speed and activate the cruise control. On the adaptive cruise control screen, the set speed and a road element are displayed in green. The accelerator pedal can be released.

Alternatively, press the + or - buttons to increase or decrease the speed and store this speed. Cruise control is immediately activated if either button is pressed. On the adaptive cruise control screen, the set speed and the road element are displayed in green.

Setting speed by the driver



The set speed can be changed by using the buttons + to increase or - to decrease the speed. Move thumb wheel repeatedly to change speed in small steps, move and hold to change speed in large steps.

Adopting speed by the speed limit recognition

A detected speed limit can be used as new value for the adaptive cruise control.

When passing the speed limit sign, OK? is automatically displayed.

Press **OK** on the steering wheel to store the suggested speed.

The suggested speed is shown as new speed setting.

After passing the speed limit sign

Press **OK** on the steering wheel.



OK? is displayed

Press **OK** to store the suggested speed.

The suggested speed is shown as new speed setting.

Traffic sign assistant ⇒ page 172

Exceeding the set speed

It is always possible to drive faster than the set speed by depressing the accelerator pedal. When the accelerator pedal is released, the vehicle returns to the stored speed. If a slower moving vehicle is ahead, the following distance selected by the driver is restored.

While the set speed is exceeded, the set speed flashes on the adaptive cruise control screen.

Warning

Acceleration by the driver deactivates automatic braking by the system. This is indicated as a pop-up warning on the cluster.

Resuming stored speed

Press **||▷** or **OK** to reactivate the adaptive cruise control at the stored speed.

Adaptive cruise control on vehicles with automatic transmission

The adaptive cruise control enables your vehicle to maintain a selected distance behind a braking vehicle until a complete stop is reached.

If the system has stopped your vehicle behind another vehicle, the green control indicator **(Ⓟ)** is displayed to the left of the set speed setting. This symbol notifies that the vehicle is held automatically in the stop position.

While the vehicle is held in the stop position, the following recommendations should be followed:

- Do not leave the vehicle.
- Do not open the load compartment.
- Do not engage the reverse gear.
- Do not drop off or pick up passengers.

Within three seconds after the vehicle has been stopped by the system, the vehicle slowly moves off again. After three seconds, accelerate or depress **(Ⓟ)** to drive away. Pay attention to the surroundings of the vehicle when driving away.

If the vehicle stays stopped for more than five minutes without any action by the driver, the electric parking brake is applied. Control indicator **(Ⓟ)** will illuminate. To release electric parking brake, press the accelerator pedal.

Electric parking brake ⇒ page 112

⚠ Warning

When the system is deactivated or cancelled, the vehicle will no longer be held at a stop and can start moving. Be always prepared to manually apply the brake to hold the vehicle stationary. Do not leave the vehicle while it is being held at a stop by adaptive cruise control. Always engage **P** and switch off the ignition before leaving the vehicle.

Setting the following distance

When the adaptive cruise control detects a slower moving vehicle in the driving path, it will adjust the vehicle speed to maintain the following distance selected by the driver.

The following distance can be set to close (1 bar), normal (2 bars) or far (3 bars).

If the engine is running and the adaptive cruise control is switched on (grey)

or active (green), you can modify the following distance setting:



Press the button to display the current following distance setting on the cluster.

Press the button successively to select the required following distance setting. The selected following distance is indicated by full bars on the adaptive cruise control screen.

⚠ Warning

The driver accepts full responsibility for the appropriate following distance based on traffic, weather and visibility conditions. Following distance must be adjusted or the system switched off when required by the prevailing conditions.

Detecting the vehicle ahead

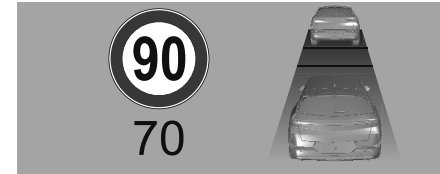

If the system detects a vehicle in the driving path, the adaptive cruise control screen changes accordingly.

Deactivation of the functionality

Press || ▷.

The adaptive cruise control is deactivated, but not disabled. The last stored set speed remains in memory for later usage.

The adaptive cruise control is deactivated automatically in the following cases:

- brake pedal depressed
- traction control system or electronic stability control is operating

- reverse gear engaged, N selected
- electric parking brake engaged
- seat belt unfastened
- driver's door opened

Switching off the system

Press ASSIST successively until the desired mode to switch off assistance is selected.

Driver's attention

- Use the adaptive cruise control carefully on bends or mountain roads, as it can lose the vehicle ahead and needs time to detect it again.
- Do not use the system on slippery roads as it can create rapid changes in tyre traction (wheel spinning), so that you could lose control of the vehicle.
- Do not use the adaptive cruise control during rain, snow or heavy dirt, as the radar sensor can be covered by a water film, dust, ice or snow. This reduces or completely suppresses visibility. In case of sensor blockage, clean the sensor cover.
- Do not use the system when the spare wheel is in use.

System limitations

⚠ Warning

The system's automatic brake force does not permit hard braking and the braking level may not be sufficient to avoid a collision.

- After a sudden lane change, the system needs a certain time to detect the next preceding vehicle. So if a new vehicle is detected, the system may accelerate instead of braking.
 - The adaptive cruise control only considers traffic driving in the same direction.
 - The adaptive cruise control does not consider pedestrians, cyclists or animals for braking and driving off.
 - The adaptive cruise control does not consider stationary vehicles
- As the radar's field of detection is quite narrow, it is possible that the system may not detect:
- vehicles of reduced width, e.g. motorcycles, scooters
 - vehicles not running in the middle of the lane
 - vehicles entering a corner

- vehicles suddenly pulling out

Deactivate the system in the following situations:

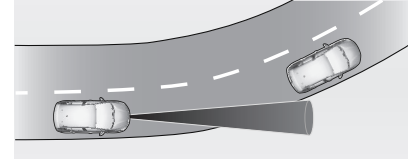

- when driving through a tight bend
- when approaching a roundabout
- when following a vehicle not detected by system, e.g., a motorcycle
- when the vehicle ahead sharply decelerates
- when a vehicle cuts in sharply between your vehicle and the vehicle ahead

Hill considerations

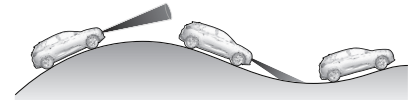

⚠ Warning

Do not use the adaptive cruise control on steep hill roads.

System performance on hills depends on vehicle speed, vehicle load, traffic conditions and the road gradient. It may not detect a vehicle in your path while driving on hills. On steep hills, you may have to use the accelerator pedal to maintain your vehicle speed. When going downhill, you may have to brake to maintain or reduce your speed. Note that applying the brake deactivates the system.

Radar unit



The radar unit is located in the middle of the front bumper.

⚠ Warning

The radar unit was aligned carefully during manufacture. Therefore, in the event of a front-end impact, do not use the system. The front bumper may appear to be intact, however the sensor behind may be affected and react incorrectly. After an accident, consult a workshop to verify and adjust the radar unit position.

⚠ Warning

The usage of a licence plate support on the front bumper may affect the proper radar unit functionality. When using a licence plate support, follow the markings and indications on the front bumper.

Fault

In the event of an adaptive cruise control fault, a warning light illuminates on the cluster and a warning message is displayed on the cluster accompanied by an audible signal. The speed limit recognition may not operate correctly if traffic signs do not comply with the Vienna Convention on Road Signs and Signals. Have the system checked by a workshop. As a safety measure, do not

use the system if the brake lights are faulty. Do not use the system if the front bumper is damaged.

Tyre deflation detection system

The tyre deflation detection system continually checks the rotation speed of all four wheels and warns on low tyre pressure condition once vehicle is driving. This is achieved by comparing tyre rolling circumference with reference values and further signals.

If a tyre loses pressure the control

indicator  illuminates and a warning message is displayed on the cluster.

Control indicator ⇨ page 79

In this case reduce speed, avoid sharp cornering and strong braking.

Stop at next safe opportunity and check tyre pressure.

After adjusting tyre pressure initialise the system to extinguish the control indicator and restart the system.

If the failure continues to be displayed, contact a workshop. The system is inoperable when the ABS or Electronic Stability Control has a fault or a

temporary spare wheel is used. Once the tyre has been refitted, check the tyre pressure with cold tyres and initialise the system.

CAUTION

Tyre deflation detection system warns just about low tyre pressure condition and does not replace regular tyre maintenance by the driver.

System initialisation

After tyre pressure correction or wheel change, the system must be initialised to learn new circumference reference values:

1. Always ensure that all four tyres have correct tyre pressure ⇒ page 196
2. Apply parking brake.
3. Initialise the system via the Information Display ⇒ page 68
4. Reset is confirmed by a message.

After initialisation the system automatically calibrates to new tyre pressures during driving. After a longer drive the system will adopt and monitor new pressures.

Always check tyre pressure with cold tyres.

The system must be reinitialised when:

- tyre pressure has been changed
- Load condition has been changed
- Wheels have been swapped or exchanged

The system will not warn instantaneously on a tyre blow out or a rapid deflation. This is due to required calculation time.

Traffic Sign Assist (TSA)

Warning

The actual traffic sign always takes priority over the traffic sign displayed on the cluster.

Depending on the version, there are two different systems available.

Intelligent speed assistance

Using the camera at the top of the windscreen and the vehicle's integrated navigation system, this system detects and reads speed limit signs and end of speed limits on the cluster. Up to two speed limit signs including supplementary signs are displayed on the cluster. If several speed limits are

recognised, the vehicle may analyse and display the valid speed limit.

When a traffic sign for a certain area, e.g. city or motorway, is recognised and the vehicle is fitted with integrated navigation, the corresponding speed limit will also be displayed.

If the system is activated but does not detect a speed limit sign, the following sign is displayed:

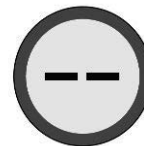

If the vehicle exceeds the speed limit by at least 5 km/h, the speed limit displayed flashes about ten seconds.

Speed limiter ⇒ page 165.

Cruise control ⇒ page 166.

Adaptive cruise control ⇒ page 166.

Activation

The speed limit function of the traffic sign assistant is activated via **Drive Assist**.

Press  below the Info Display and activate **Drive Assist**.



Press  on the steering wheel repeatedly until the Drive Assist mode is selected.

The **Drive Assist** screen is displayed on the cluster.

Info Display ⇨ page 68

Deactivation



Press  repeatedly until the mode to switch off assistance is selected.

Updating navigation map data

To maintain the performance of the system, the navigation map should be updated at periodic intervals.

Further information is available in the Infotainment system section.

Advanced Intelligent Speed Assistance

This system permanently displays speed limit information on the cluster irrespective of vehicle speed.

Providing the speed limit information involves the following systems, depending on version:

- camera at the top of the windscreen
- vehicle's integrated navigation system
- telematics service

If travelling on a road with no speed restrictions, e.g., on German motorways, the following sign is displayed:



If no speed limit information can be provided, the following sign is displayed:

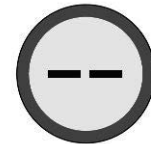

If a new speed limit is provided, a confirmation chime is given. The confirmation chime can be activated / deactivated on the Info Display.

Info Display ⇨ page 68

If driving at a speed of at least 20 km/h and exceeding the speed limit, the speed limit displayed on the cluster flashes after some time and an audible signal is given after some time.

Time of occurrence varies. Both flashing and audible signal are terminated after a few seconds. Due to legal requirements, the audible signal can only be deactivated until the next time the ignition is switched on.

Depending on version, the audible signal can be deactivated by:

- long-press on 
- long-press on the button



- long-press on 

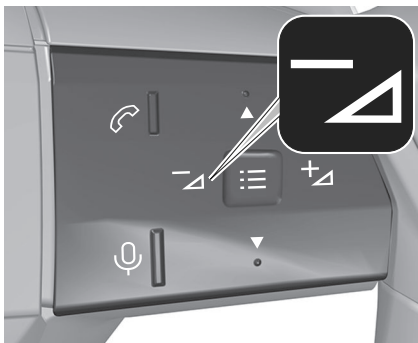

If the audible signal is deactivated,  illuminates for a few seconds.

In case of a failure,  illuminates permanently. Consult a workshop.

Speed limiter ⇒ page 165

Cruise control ⇒ page 166

Adaptive cruise control ⇒ page 166

Fault

If the system has a fault,  illuminates on the cluster, a message is displayed and an audible signal is given. Consult a workshop.

 illuminates on the cluster accompanied by a message indicating

that the camera may be covered. Stop the vehicle and check, if the

camera needs to be cleaned. If  still illuminates after cleaning the camera, consult a workshop.

Operation conditions

To provide country-specific speed limit information, the vehicle needs to identify the country it is currently in. If a corresponding country list is available on the Info Display, the respective country has to be selected manually. Otherwise, the country is automatically selected.

To get valid speed limit information, the vehicle's current position is sent via the telematics unit and is immediately deleted after processing.

Tracking of the vehicle position is not possible at any time.

This is not impacted by the privacy settings of Vauxhall Connect.

Note

It is possible to report a permanent speed limit misinformation on our website.

Updating data

To maintain the performance of the system, the vehicle software and the

navigation map should be updated in periodical intervals.

A navigation map update is available at least once per year. Further information is available in the Infotainment system section.

For vehicle software update consult a workshop.

System limitations

Traffic sign assistant may not operate properly when:

- Driving on winding or hilly roads.
 - Driving with snow chains.
 - The area of the windscreen, where the front camera is located, is not clean or affected by foreign items, e.g. stickers.
 - The visibility is limited because of the weather, such as fog, rain, or snow.
 - The vehicle ahead is creating road spray.
 - Dazzling light, e.g. caused by the sun or artificial illumination shining directly into the camera lens.
 - Speed limitation is painted on the surface of the road.
 - Traffic signs are completely or partially covered or difficult to discern.
- Traffic signs are incorrectly mounted or damaged or have been removed.
 - Traffic signs do not comply with the Vienna Convention on Road Signs and Signals.
 - Depending on version, the navigation map data may be outdated.

CAUTION

The system is intended to help the driver within a defined speed range to recognise certain traffic signs. Do not ignore traffic signs that are not displayed by the system.

Do not let this special feature tempt you into taking risks when driving.

Always adapt speed regarding road, traffic and weather conditions.

The driver assistance systems do not relieve the driver from full responsibility for vehicle operation.

When driving abroad make sure the vehicle uses the speed unit of the respective country. If necessary, select the correct units on the Info Display.

In case of emergency

Hazard warning flashers.....	176
Assist and SOS.....	176
Emergency call.....	176
Vauxhall Connect.....	177
Warning triangle.....	177
Assembling and placing the triangle	177
Tool kit.....	177
List of tools.....	178
Spare wheel.....	178
Changing a wheel.....	179
Tyre repair kit.....	181
Jump starting.....	183
Towing.....	185
Towing the vehicle.....	185
Towing another vehicle.....	186

Hazard warning flashers



Press the button to operate.

When braking in an emergency, the hazard warning flashers are switched on automatically, depending on the force of deceleration.

Assist and SOS

EMERGENCY CALL

Note

In order to be available and operational, the system requires functioning vehicle electrics, mobile service and GPS satellite link. Depending on equipment, a backup battery is used.

Note

The service is only available for markets where it is legally required.

Furthermore, it depends on the availability of the emergency centres and on the infrastructure in the country.

Status LED in the overhead console

Illuminates green and red and extinguishes after a short time, when the ignition is switched on: the system works properly.

Illuminates red: fault in the system.

Contact a workshop.

Flashes red: backup battery needs replacement. Contact a workshop.

Emergency call

The emergency call function will establish a connection to the nearest public safety answering point (PSAP).

A minimum set of data including vehicle and location information will be sent to the PSAP.

In case of an emergency, press the red SOS button in the overhead console for more than two seconds.

The LED flashes green to confirm that a connection to the nearest PSAP is being established. The LED illuminates steadily as long as the call is active.

Pressing the SOS button immediately a second time will terminate the call.

The LED switches off.

Automatic crash notification

In case of an accident with airbag deployment and without damage of needed hardware, an automatic emergency call is established and an automatic crash notification will be transmitted to the next PSAP.

VAUXHALL CONNECT

Vauxhall Connect comprises multiple connected services accessible via app, online or within the vehicle.

Note

Full functionality of Vauxhall Connect is subject to registration and proper activation.

Connected services may include live navigation such as online traffic information and vehicle status and information such as maintenance alerts.

Services accessible within the vehicle also include emergency call and

breakdown call. These functions are automatically activated. Terms and conditions apply.

Breakdown call

Pressing the  button in the overhead console for more than two seconds connects to a roadside assistance service provider.

For information about coverage and scope of services of the roadside assistance, please refer to the information provided by the Vauxhall Distributor with the order form.

Privacy settings

Privacy settings of Vauxhall Connect can be configured. This will impact the set of data being sent, e.g., in case a breakdown call is triggered. The emergency call function and the traffic sign assistant will not be impacted.

Depending on version, the privacy settings can be changed by

simultaneously pressing  and SOS in the overhead console or via the system settings menu in the Info Display.

Warning triangle

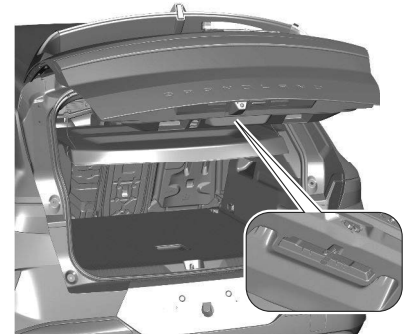

Stow the warning triangle in the space in the tailgate and secure it with the Velcro® fastener.

ASSEMBLING AND PLACING THE TRIANGLE

If the triangle is supplied as an accessory, refer to the assembly instructions provided with the triangle.

- Put the triangle in place behind the vehicle, as required by local legislation.

Tool kit

Set of tools supplied with the vehicle.

Warning

The tool kit is specific to the vehicle and may vary depending on version.

Do not use it for any other purposes.

LIST OF TOOLS

Depending on the version, the vehicle tools are located in a toolbag in the load compartment either behind the third row or below the floor cover.

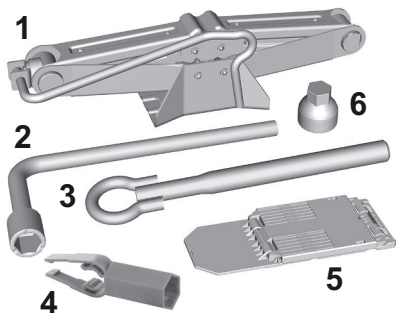

- 1-Jack
- 2-Wheel wrench
- 3-Towing eye
- 4-Wheel bolt cover remover
- 5-Chock

- 6-Adapter for the locking wheel nuts

Depending on version, the chock, the towing eye and the adapter for the locking wheel nuts may be located in a bag together with the tyre repair kit → page 181.

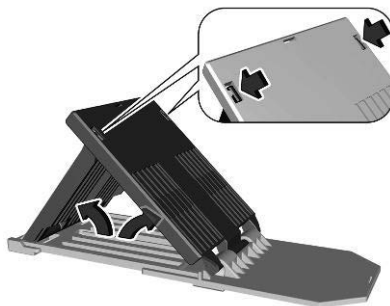

For vehicles with spare wheel the jack and wheel wrench is located in a toolbox inside the spare wheel → page 178.

Vehicles without spare wheel

Open the floor cover of the load compartment.

The towing eye is located in a bag → page 181.

SPARE WHEEL

The spare wheel can be classified as a temporary spare wheel depending on

the size compared to the other mounted wheels and country regulations. In this case a permissible maximum speed applies, even though no label at the spare wheel indicates this.

If there is a label on the spare wheel, the permissible speed still depends on the country regulations.

Only mount one temporary spare wheel. Take curves slowly. Do not use for a long period of time.

CAUTION

The use of a spare wheel that is smaller than the other wheels or in combination with winter tyres could affect driveability. Have the defective tyre replaced as soon as possible.

Depending on version the spare wheel is located in the load compartment beneath the floor covering or in a holder beneath the vehicle floor.

Removing the spare wheel

1. Open the floor cover.
2. The spare wheel is secured with a wing nut. Unscrew nut and take out the spare wheel.

3. If, after a wheel change, no wheel is placed in the spare wheel well, fasten the wing nut and close the floor cover.
4. After a wheel change back to a full-size wheel, place the spare wheel outside up in the well and secure with the wing nut.

CHANGING A WHEEL

Make the following preparations and observe the following information:

- Park the vehicle on a level, firm and non-skid surface. The front wheels must be in the straight-ahead position.
- Apply the parking brake and engage first gear, reverse gear or **P**.
- Place a chock under the wheel diagonally opposite the wheel to be changed.
- Remove the spare wheel.
- Never change more than one wheel at once.
- Use the jack only to change wheels in case of puncture, not for seasonal winter or summer tyre change.
- The jack is maintenance-free.
- If the ground on which the vehicle is standing is soft, a solid board (max. 1

cm thick) should be placed under the jack.

- Take heavy objects out of the vehicle before jacking up.
- No people or animals may be in the vehicle when it is jacked up.
- Never crawl under a jacked-up vehicle.
- Do not start the vehicle when it is raised on the jack.
- Before screwing in the wheel bolts, clean them.

Warning

Do not grease wheel bolts.

Warning

Ensure to use always the correct wheel bolts if changing the wheels. When installing the spare wheel for temporary usage, the bolts for alloy wheel rims can also be used.

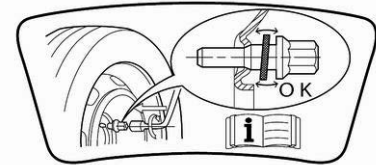

Note that the spare wheel is secured by the conical contact of each bolt if the wheel bolts for the alloy wheel rims are used. In this case, the washers do not come into contact with the spare wheel.

1. Disengage wheel bolt caps with the wheel bolt cover remover.

Vehicle tools ⇒ page 178

Steel wheel rims with cover: Pull off the wheel cover.



Attach the wheel wrench and loosen each wheel bolt by half a turn.

The wheels might be protected by locking wheel bolts. To loosen these specific bolts, first attach the adapter for the locking wheel bolts onto the head of the bolt before installing the wheel wrench.

The adapter for the locking wheel nuts may be located in a toolbag in the load compartment or in a bag together with the tyre repair kit.

Vehicle tools ⇒ page 178

Tyre repair kit ⇒ page 181

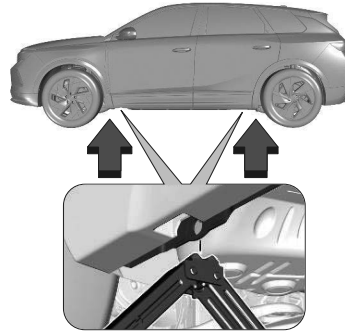

1. Ensure the jack is correctly positioned under the relevant vehicle jacking point.
2. Set the jack to the necessary height. Position it directly below the jacking point in a manner that prevents it from slipping.
3. Ensure that the edge of the body fits into the notch of the jack.
4. With the jack correctly aligned, jack up until wheel is clear of the ground.
5. Unscrew the wheel nuts.
6. Change the wheel.
7. Screw on the wheel nuts.
8. Lower the vehicle and remove jack.

9. Install the wheel wrench ensuring that it is located securely and tighten each bolt in a crosswise sequence. Tightening torque is 100 Nm.

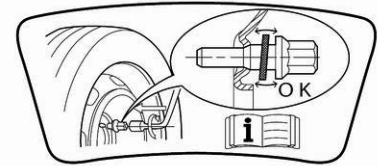

10. If the vehicle is equipped with alloy wheel rims, note that the wheel bolts can also be used for the spare wheel. In this case, the spare wheel is secured by the conical contact of each bolt.
11. Install wheel nut caps.
12. Stow and secure the replaced wheel and the tools.
13. Check the tyre pressure of the installed tyre and the tightening torque as soon as possible.

Stowing a damaged full size wheel in the load compartment

The spare wheel well is not designed for other tyre sizes than the spare wheel. A damaged full size wheel must be stowed in the load compartment and secured properly.

Loading information⇒ page 54 .

Tyre repair kit

Minor damage to the tyre tread can be repaired with the tyre repair kit.

Do not remove foreign bodies from the tyres.

Tyre damage exceeding 4 mm or that is at tyre's sidewall cannot be repaired with the tyre repair kit.

Warning

Do not drive faster than 50 mph. Do not use for a lengthy period. Steering and handling may be affected.

In the case of a flat tyre:

Apply the parking brake and engage first gear, reverse gear or **P**.

Depending on the version, the location of the tyre repair kit is different:

- at the left side of the load compartment
- below the third row seats with the seats folded
- behind the third row seat with the seats unfolded.

1. Remove the sealant bottle and the compressor.
2. Pull the speed-limit label from the sealant bottle and place it in driver's visible area.

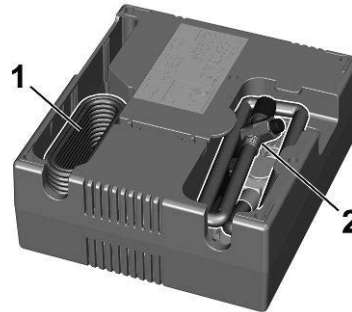

3. Remove the electric connection cable (1) and air hose (2) from the stowage compartments on the underside of the compressor.



4. Open the sealant bottle and lift the lid.

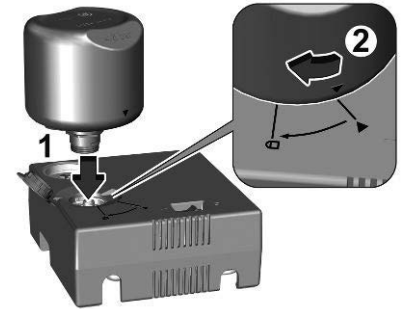

5. First, insert the sealant bottle into the compressor and align the triangle symbols. Then, push down the sealant bottle and turn it to the lock position.
6. Set the compressor near the tyre in such a way that the sealant bottle is upright.

7. Unscrew the valve cap from the defective tyre.

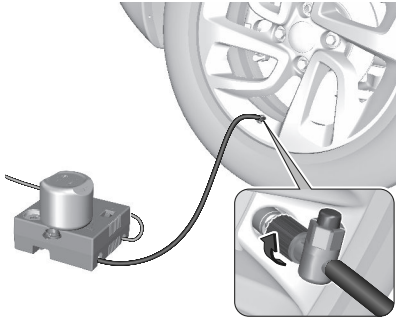

8. Screw the filler hose to the tyre valve.
9. The switch on the compressor must be set to **O**.
10. Connect the compressor plug to the 12 V power outlet.

To avoid discharging the vehicle battery, we recommend to use the tyre repair kit only when the combustion engine is running or when the electric engine is ready.

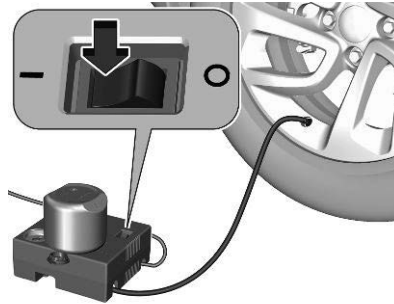

11. Set the rocker switch on the compressor to **I**. The tyre is filled with sealant.
12. The compressor pressure gauge briefly indicates up to 600 kPa (6 bar) whilst the sealant bottle is emptying (approx. 30 seconds). Then the pressure starts to drop.
13. All of the sealant is pumped into the tyre. Then the tyre is being inflated.
14. The prescribed tyre pressure should be obtained within 10 minutes.

Tyre pressure ⇒ page 215 .

When the correct pressure is obtained, switch off the compressor.

If the prescribed tyre pressure is not obtained within 10 minutes, remove

the tyre repair kit. Move the vehicle one tyre rotation.

Reattach the tyre repair kit and continue the filling procedure for 10 minutes. If the prescribed tyre pressure is still not obtained, the tyre is too badly damaged. Seek the assistance of a workshop.

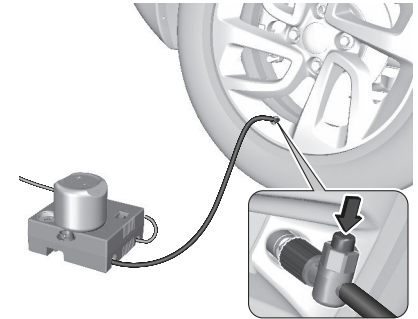

Drain excess tyre pressure with the button on the air hose.

Do not run the compressor longer than 10 minutes.

15. Detach the tyre repair kit. Remove the sealant bottle from the compressor.

Screw the filler hose to the free connection of the sealant bottle.

This prevents sealant from escaping. Stow the tyre repair kit in its designated position.

16. Remove any excess sealant using a cloth.

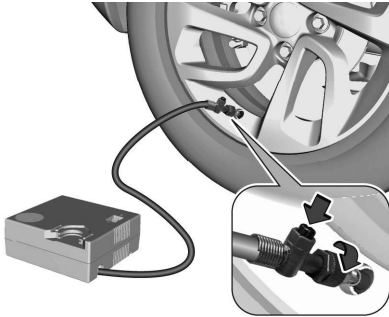

17. Continue driving immediately so that sealant is evenly distributed in the tyre. Drive between 12 mph and 38 mph. After driving approx. 3 miles but no more than 10 minutes, stop and check tyre pressure. Screw compressor air hose directly onto tyre valve when doing this. Fill tyre as described before. Drain excess tyre pressure with the button on the air hose. If tyre pressure hasn't decreased under 200 kPa (2 bar), set it to the correct value. Otherwise the vehicle must not be used. Seek assistance of a workshop. Repeat the checking procedure once more after

driving a further 6 miles but no more than 10 minutes, to check that there is no more loss of pressure. If the tyre pressure has fallen below 200 kPa (2 bar), the vehicle must not be used. Seek the assistance of a workshop.

18. Stow the tyre repair kit in its designated position.

Note

The driving characteristics of the repaired tyre are severely affected, therefore have this tyre replaced.

If unusual noise is heard or the compressor becomes hot, turn the compressor off for at least 30 min.

The built-in safety valve opens at a pressure of 700 kPa (7 bar).

Note the expiry date of the kit. After this date its sealing capability is no longer guaranteed. Pay attention to the storage information on the sealant bottle.

Replace the used sealant bottle.

Dispose of the bottle as prescribed by applicable laws.

The compressor and sealant can be used from approx. -30 °C.

Jump starting

CAUTION

Only jump start another vehicle with a vehicle with an ICE

Do not start with quick charger.

A vehicle with a discharged vehicle battery can be started using jump leads and the vehicle battery of another vehicle.

Warning

Be extremely careful when starting with jump leads. Any deviation from the following instructions can lead to injuries or damage caused by battery explosion or damage to the electrical systems of both vehicles.

Warning

Avoid contact of the battery with eyes, skin, fabrics and painted surfaces. The fluid contains sulphuric acid, which can cause injury and damage in the event of direct contact.

- Never expose the vehicle battery to naked flames or sparks.

- A discharged vehicle battery can already freeze at a temperature of 0 °C. Defrost the frozen battery before connecting jump leads.
- Wear eye protection and protective clothing when handling a battery.
- Use a booster battery with the same voltage (12 V). Its capacity (Ah) must not be much less than that of the discharged vehicle battery.
- Use jump leads with insulated terminals and a cross-section of at least 16 mm².
- Do not disconnect the discharged vehicle battery from the vehicle.
- Switch off all unnecessary electric consumers.
- Do not lean over the vehicle battery during jump starting.
- Do not allow the terminals of one lead to touch those of the other lead.
- The vehicles must not come into contact with each other during the jump starting process.
- Apply the parking brake, transmission in **P**.

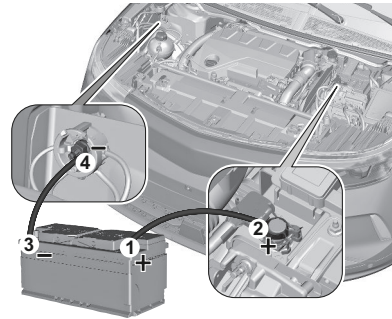

Open the positive terminal protection caps of both vehicle batteries.

Lead connection order:

1. Connect the red lead to the positive terminal of the booster battery (1).
2. Connect the other end of the red lead to the positive terminal of the discharged battery (2).
3. Connect the black lead to the negative terminal of the booster battery (3).
4. Connect the other end of the black lead to a vehicle earthing point of your vehicle in the engine compartment (4).

Route the leads so that they cannot catch on rotating parts in the engine compartment.

To start the engine:

1. Start the engine of the vehicle providing the jump.
2. After five minutes, start the other engine. Start attempts should be made for no longer than 15 seconds at an interval of one minute.
3. Allow both engines to idle for approx. three minutes with the leads connected.
4. Switch on electric consumers e.g. headlights, heated rear window.
5. Reverse above sequence exactly when removing leads.

Towing

TOWING THE VEHICLE

Front cap



Remove the cap.

The towing eye is stowed with the vehicle tools ⇒ page 177

Front towing eye

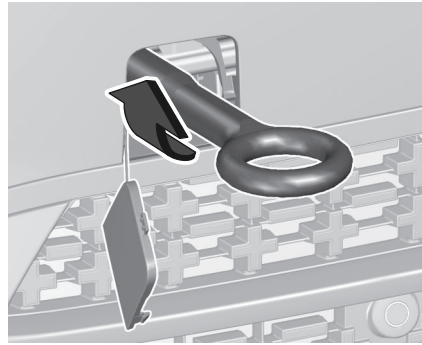

Screw in the towing eye as far as it will go, until it stops in a horizontal position.

Attach the tow rod to the towing eye.

The towing eye must only be used for towing and not for recovering the vehicle.

Switch on ignition to release steering wheel lock and to permit operation of brake lights, horn and windscreen wiper.

CAUTION

Deactivate the driver assistance systems, such as active emergency braking, otherwise the vehicle may automatically brake during towing.

Switch the selector lever to neutral.

Release the parking brake.

CAUTION

Drive slowly.

Do not drive jerkily.

When the engine is not running, considerably more force is needed to brake and steer.

To prevent the entry of exhaust gases from the towing vehicle, switch on the air recirculation and close the windows.

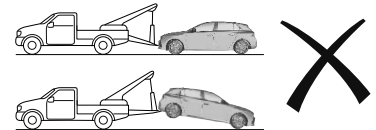
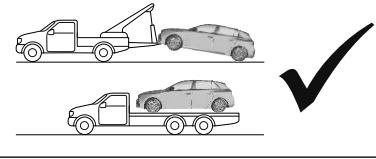

When towing the vehicle, always lift the driven wheels off the road. In the case of the BEV AWD version, carry the vehicle on the platform.

Seek the assistance of a workshop.

After towing, unscrew the towing eye.

Insert cap with the outer flange into the recess and fix cap by pushing.

TOWING ANOTHER VEHICLE

Rear cap

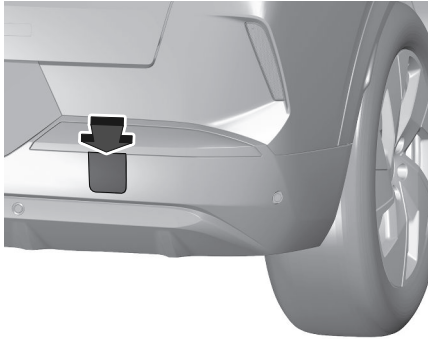

Remove the cap.

The towing eye is stowed with the vehicle tools ⇒ page 178.

Rear towing eye

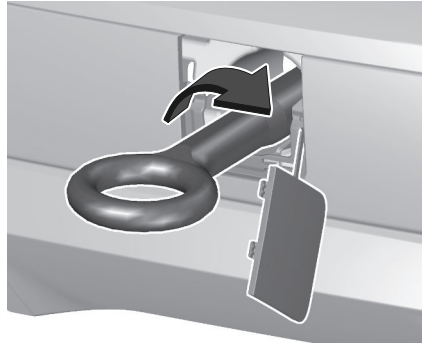

Screw in the towing eye as far as it will go until it stops in a horizontal position.

Attach a tow rope — or better still, a tow rod — to the towing eye.

The towing eye must only be used for towing and not for recovering a vehicle.

CAUTION

Drive slowly.

Do not drive jerkily.

After towing, unscrew the towing eye.

Insert cap with the upper flange into the recess and fix cap by pushing.

Maintenance and vehicle care

General information.....	187
Accessories and vehicle modifications	187
Cold protection covers.....	188
Vehicle storage.....	189
End-of-life vehicle disposal.....	189
Vehicle checks.....	190
Performing work.....	190
.....	190
Vehicle battery.....	192
Recommended fluids, lubricants and parts.....	194
Washer fluid.....	195
Fuses.....	196
Bulb replacement.....	196
Tyres and wheels.....	196
Tyre safety information.....	196
Tyre pressure.....	196
Tread depth.....	197
Winter tyres.....	198
Wheel covers.....	198
Bodywork - exterior care.....	198
Interior care.....	199
Plastic and coated parts.....	200
Floor mats.....	200

General information

In order to ensure economical and safe vehicle operation and to maintain the value of your vehicle, it is of vital importance that all maintenance work is carried out at the proper intervals.

The detailed, up-to-date service schedule for your vehicle is available at the workshop.

Severe operating conditions exist if one or more of the following circumstances occur frequently: Cold starting, stop and go operation, e.g. for taxis and police vehicles, trailer operation, mountain driving, driving on poor and sandy road surfaces, increased air pollution, presence of airborne sand and high dust content, driving at high altitude and large variations in temperature.

Under these severe operating conditions, certain service work may be required more frequently than the regular service interval indicated in the service display. Contact a workshop for customised service schedules.

Confirmations

Confirmation of service is recorded in the Service and warranty booklet.

The date and mileage is completed with the stamp and signature of the servicing workshop.

Make sure that the Service and warranty booklet is completed correctly, as continuous proof of service is essential if any warranty or goodwill claims are to be met, and is also a benefit when selling the vehicle.

ACCESSORIES AND VEHICLE MODIFICATIONS

We recommend the use of genuine parts and accessories and factory-approved parts specific for this vehicle type. We cannot assess or guarantee reliability of other products — even if they have a regulatory or otherwise granted approval.

Any modification, conversion or other changes made to standard vehicle specifications (including, without limitation, software modifications, modifications of the electronic control units) may invalidate the warranty offered by Vauxhall.

Furthermore, such changes may affect driver assistance systems, may impact fuel consumption, CO₂ emissions and other emissions of the vehicle and cause the vehicle to no longer conform to the

operating permit, impacting the validity of your vehicle registration.

CAUTION

Access to the diagnostic socket associated with the on-board electronics is reserved for qualified technicians and approved tools.

CAUTION

When transporting the vehicle on a train or on a recovery vehicle, the mud flaps might be damaged.

Mobile phones and CB radio equipment

The vehicle specific installation instructions and the operating guidelines of the mobile phone and hands-free manufacturer must be observed when installing and operating a mobile telephone. Failure to do so could invalidate the vehicle type approval.

Recommendations for fault-free operation:

- Professionally installed exterior antenna to obtain the maximum range possible.
- Maximum transmission power 10W.

- Installation of the phone in a suitable spot, consider the area in which the airbag inflates ⇨ page 29.

Seek advice on predetermined installation points for the external antenna or equipment holder and ways of using devices with a transmission power exceeding 10W.

Use of a hands-free attachment without external antenna with mobile telephone standards GSM 900/1800/1900 and UMTS is only permitted if the maximum transmission power of the mobile telephone is 2W for GSM 900 or 1W for the other types.

For reasons of safety, do not use the phone while driving. Even use of a hands-free set can be a distraction while driving.

Warning

Operation of radio equipment and mobile telephones that fail to meet above mentioned mobile telephone standards is only permitted using an antenna located outside of the vehicle.

CAUTION

Mobile telephones and radio equipment may lead to malfunctions in the vehicle electronics when operated inside the vehicle with no exterior antenna, unless the above mentioned regulations are observed.

COLD PROTECTION COVERS

It is recommended to have the cold protection covers installed by a workshop.

DANGER

The cold protection covers must be removed when one of the following conditions occurs:

- The ambient temperature is above 10 °C.
- The vehicle is towing a trailer.
- The vehicle is driven at speeds above 120 km/h.

VEHICLE STORAGE

Long-time storage of a hybrid / electric vehicle

If the vehicle is to be stored for several months:

- Wash the vehicle.
- Have the wax in the engine compartment and underbody checked.
- Clean and preserve the rubber seals.
- Drain the washer fluid reservoir.
- Check the coolant antifreeze and corrosion protection.
- Adjust tyre pressure to the value specified for full load.
- Park the vehicle in a dry, well ventilated place. Engage first or reverse gear or set selector lever to **P**. Prevent the vehicle from rolling.
- Do not apply the parking brake.
- Open the bonnet, close all doors and lock the vehicle.

Up to four weeks

Plug in the charging cable.

Four weeks to twelve months

- Discharge the high-voltage battery until 30 percent remain on the battery

range indicator (battery symbol) on the cluster.

- Do not plug in the charging cable.
- Always store the vehicle in a place with temperatures between -10 °C and 30 °C.
- Vehicle storage at extreme temperatures may cause damage to the high-voltage battery.
- Remove the black negative (-) cable from the 12 V vehicle battery and attach a trickle charger to the vehicle battery terminals, or keep the 12 V vehicle battery cables connected and trickle charge from the positive (+) and negative (-) terminals in the engine compartment.
- Every three months, check the battery's state of charge. If the state of charge is below 30 percent, recharge the battery to 30 percent.

Putting back into operation

When the vehicle is to be put back into operation:

- Connect the clamp to the negative terminal of the vehicle battery. Initialise the power windows ⇒ page 14
- Check tyre pressure
- Fill up the washer fluid reservoir.

- Check the engine oil level.
- Check the coolant level.
- Fit the number plate if necessary.

END-OF-LIFE VEHICLE DISPOSAL

Information on end-of-life vehicle recovery centres and the recycling of end-of-life vehicles is available on our website, where legally required. Only entrust this work to an authorised recycling centre.



Vehicle checks

PERFORMING WORK

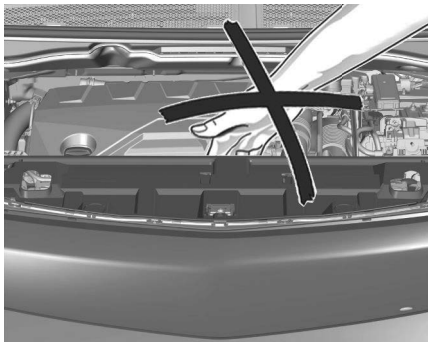

Warning

Only perform engine compartment checks when the ignition is off.

The cooling fan may start operating even if the ignition is off.

BEV

DANGER

The ignition system uses extremely high voltage. Do not touch.



DANGER

Never try to perform maintenance work on high-voltage components yourself. You may be injured and the vehicle may be damaged. Service and repair of these high-voltage components should only be performed by a trained service technician with proper knowledge and tools. Exposure to high voltage may cause shock, burns and even death. The high-voltage components in the vehicle can only be serviced by technicians with special training.

High-voltage components are identified by labels. Do not remove, open, take apart or modify these components. High-voltage cable or wiring has orange covering. Do not probe, tamper with, cut or modify high-voltage cable or wiring.

CAUTION

Even small amounts of contamination to the liquids can cause damage to vehicle systems. Do not allow contaminants to contact the fluids, reservoir caps or dipsticks.

Engine oil

Check the engine oil level manually on a regular basis to prevent damage to the engine. Ensure that the correct specification of engine oil is used.

Recommended fluids and lubricants ⇨ page 194

The maximum engine oil consumption is 0.6 l per 600 miles.

Check with the vehicle on a level surface. The engine must be at operating temperature and switched off for at least five minutes.

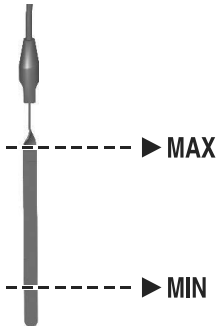
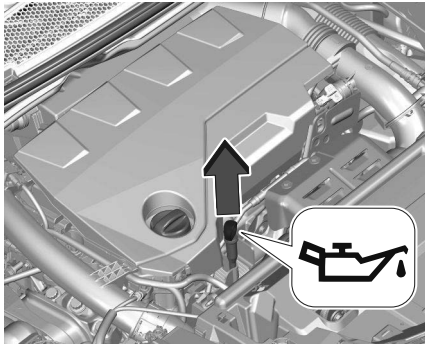

Pull out the dipstick, wipe it clean, reinsert it fully, pull out and read the engine oil level.

Different dipsticks are used depending on engine variant.

⚠ Warning

Insert dipstick fully up to the stop on the handle.

Ensure that no engine oil gets into the engine compartment, as this increases risk of fire.

When the engine oil level has dropped to the **MIN** mark, top up the engine oil. We recommend the use of the same grade of engine oil that was used at last oil change.

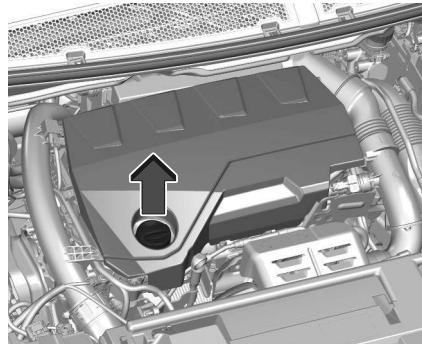

The engine oil level must not exceed the **MAX** mark on the dipstick.

CAUTION

Overfilled engine oil must be drained or suctioned out. If the engine oil exceeds the maximum level, do not start the vehicle, and contact a workshop.

Fit the cap on straight and tighten it.

Engine coolant

The factory filled coolant provides freeze protection down to approx. -37 °C.

CAUTION

An excessively low coolant level can cause damage to the high-voltage components.

CAUTION

Only use approved antifreeze.

Coolant and antifreeze ⇒ page 194.

Coolant level PHEV/BEV

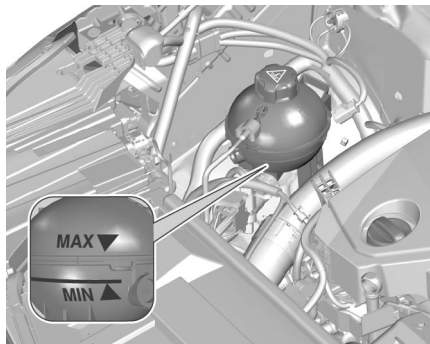

If the coolant level is at the MIN mark or below, seek the assistance of a workshop to have the engine coolant topped up.

CAUTION

Using the wrong engine coolant can cause severe damage to the high-voltage battery. Only experienced mechanics are allowed to open the coolant reservoir and top up coolant.

Coolant level ICE and hybrid 48 V

If the cooling system is cold, the coolant level should be above the MIN mark. Top up if the level is low.

Warning

Allow the engine to cool before opening the cap. Carefully open the cap, relieving the pressure slowly.

To top up, use a 1:1 mixture of released coolant concentrate mixed with clean tap water. If no coolant concentrate is available, use clean tap water. Install the cap tightly.

Have the coolant concentration checked and have the cause of the coolant loss remedied by a workshop.

Brakes

Depending on the driving style, the brake wear may vary significantly. The brake wear may increase when the vehicle is driven over short distances, e.g. in the city.

It may be necessary to have the condition of the brakes checked, even between vehicle services.

Unless there is a leak in the circuit, a drop in the brake fluid level indicates that the brake pads are worn.

Once new brake linings are installed, do not brake unnecessarily hard for the first few journeys.

Brake fluid

Warning

Brake fluid is poisonous and corrosive. Avoid contact with eyes, skin, fabrics and painted surfaces.

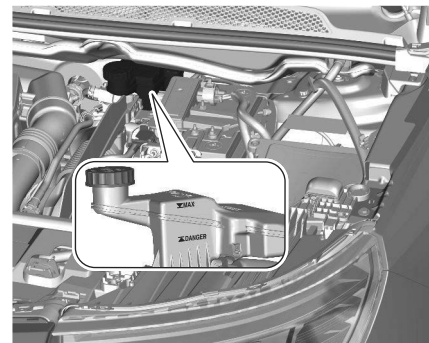

The brake fluid level must be between the **MIN** and **MAX** marks.

If fluid level is below **MIN**, seek the assistance of a workshop.

VEHICLE BATTERY

The vehicle battery is maintenance-free provided that the driving profile allows sufficient charging of the battery. Short-distance driving and frequent

engine starts can discharge the battery. Avoid the use of unnecessary electric consumers.



Batteries do not belong in household waste. They must be disposed of at an appropriate recycling collection point.

Not using the vehicle for more than four weeks can lead to battery discharge. Disconnect the clamp from the negative terminal of the vehicle battery.

Ensure the ignition is switched off before connecting or disconnecting the vehicle battery.

Battery discharge protection ⇒ page 50.

Anti-theft alarm system ⇒ page 10

Warning label



Meaning of symbols:

- No sparks, naked flames or smoking.
- Always shield eyes. Explosive gases can cause blindness or injury.
- Keep the vehicle battery out of reach of children.
- The vehicle battery contains sulphuric acid which could cause blindness or serious burn injuries.
- See the Owner's Manual for further information.
- Explosive gas may be present in the vicinity of the vehicle battery.

Replacing the vehicle battery

Note

Any deviation from the instructions given in this section may lead to temporary deactivation or disturbance of the stop-start system.

When the vehicle battery is being replaced, ensure that there are no open ventilation holes in the vicinity of the positive terminal. If a ventilation hole is open in this area, it must be closed off with a dummy cap, and the ventilation in the vicinity of the negative terminal must be opened.

Ensure that the vehicle battery is always replaced with the same type of battery.

All battery information can be found online at <https://public-servicebox.opel.com/OVddb/OV/index.html>.

The vehicle battery must be replaced by a workshop.

Stop-start system ⇒ page 109

Charging the vehicle battery

Warning

On vehicles with stop-start system, ensure that the charging potential does not exceed 14.6 V when using a battery charger.

Otherwise the vehicle battery may be damaged.

Jump starting ⇒ page 183

Discharge protection

Battery voltage

When the vehicle battery voltage is running low, a warning message will appear on the cluster.

When the vehicle is being driven, the load reduction function temporarily deactivates certain functions, e.g. the heated rear window, the heated steering wheel, etc.

The deactivated functions are reactivated automatically as soon as conditions permit.

Idle boost

If charging of the vehicle battery is required due to battery condition, the power output of the generator must be

increased. This will be achieved by an idle boost that may be audible.

A message appears on the cluster.

Power outlet

The power outlets are deactivated in the event of low vehicle battery voltage.

Power saving mode

This mode deactivates electrical consumers to avoid excessive discharging of the vehicle battery.

These consumers, such as the infotainment system, windscreen wipers, low beam headlights, courtesy light, etc. can be used for a total maximum time of about 40 minutes after ignition is switched off.

Changing into power saving mode

When power saving mode is activated, a message appears on the cluster, when the ignition has been switched off.

An active telephone call using the hands-free option will be maintained for around 10 minutes longer.

Deactivating power saving mode

Power saving mode is deactivated automatically when the engine is

restarted. Run the engine for a sufficient charge:

- for less than 10 minutes to use the consumers for approx. 5 minutes
- for more than 10 minutes to use the consumers for up to approx. 30 minutes

Heating functionalities

Note

Individual heating functionalities, such as heated seats or heated steering wheel, may be temporarily unavailable in the event of electric loading constraints. Functions will be resumed after some minutes.

Recommended fluids, lubricants and parts

Only use products that meet the recommended specifications.

Warning

Operating materials are hazardous and could be poisonous. Handle with care. Pay attention to information given on the containers.

Engine oil

Engine oil is identified by its quality and its viscosity. Quality is more important than viscosity when selecting which engine oil to use. The engine oil quality ensures e.g. engine cleanliness, wear protection and engine oil ageing control, whereas viscosity grade gives information on the engine oil's thickness over a temperature range.

Use the appropriate engine oil given on the service schedule sheet handed over by the selling dealer.

Additional engine oil additives

The use of additional engine oil additives could cause damage and invalidate the warranty.

Engine oil viscosity grades

Engine oil is identified by its quality and its viscosity. Quality is more important than viscosity when selecting which engine oil to use. The engine oil quality ensures e.g. engine cleanliness, wear protection and engine oil ageing control, whereas viscosity grade gives information on the engine oil's thickness over a temperature range.

Use the appropriate engine oil given on the service schedule sheet handed over by the selling dealer.

Coolant and antifreeze

Use only antifreeze approved for the vehicle. Consult a workshop.

The system is factory filled with coolant designed for excellent corrosion protection and frost protection down to approx. -28°C . In cold regions with very low temperatures the factory filled coolant provides frost protection down to approx. -37°C .

This concentration should be maintained all year round. The use of additional coolant additives that intend to give additional corrosion protection or seal against minor leaks can cause function problems. Liability for consequences resulting from the use of additional coolant additives will be rejected.

Washer fluid

Use only washer fluid approved for the vehicle to prevent damage of wiper blades, paintwork, plastic and rubber parts. Consult a workshop.

Brake and clutch fluid

Over time, brake fluid absorbs moisture, which will reduce braking effectiveness. The brake fluid should therefore be replaced at the specified interval.

Use only brake fluid approved for the vehicle. Consult a workshop.

WASHER FLUID

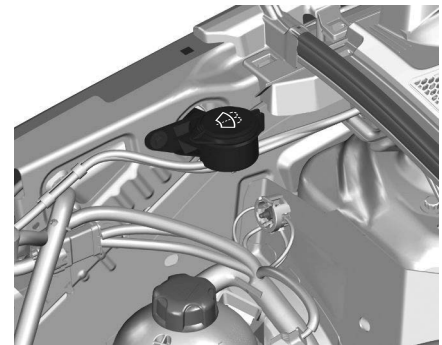

Fill with clean water mixed with a suitable quantity of approved windscreen washer fluid that contains antifreeze.

CAUTION

Only washer fluid with a sufficient antifreeze concentration provides protection at low temperatures or a sudden drop in temperature.

Washer fluid ⇨ page 194

Fuses

Changing a fuse

A defective fuse must be replaced by a workshop.

Bulb replacement

Exterior lights are designed as LEDs and cannot be changed. Have exterior and interior lights repaired by a workshop in case of failure.

Tyres and wheels

The inflation pressure of all tyres, including the spare wheel, must be checked on "cold" tyres. The pressures indicated on the tyre pressure label are valid for "cold" tyres. If you have driven for more than 10 minutes or more than 6 miles (10 kilometres) at over 31 mph (50 km/h), add 0.3 bar (30 kPa) to the values indicated on the label.

Warning

Under-inflation increases energy consumption. Non-compliant tyre pressures cause tyres to wear prematurely and have an adverse effect on the vehicle's road holding - risk of accident!

Driving with worn or damaged tyres reduces the braking and road holding performance of the vehicle. Regularly check the condition of the tyres (tread and sidewalls) and rims as well as the presence of the valve caps.

When the wear indicators no longer appear set back from the tread, the depth of the grooves is

less than 1.6 mm; replace the tyres as soon as 7 possible.

Using different size wheels and tyres from those specified can affect the lifetime of tyres, wheel rotation, ground clearance, the speedometer reading and have an adverse effect on road holding.

Fitting different tyres on the front and rear axles can cause the ESC to mistime.

Always mark the direction of rotation on the tyres that will be stored when fitting winter or summer tyres. Store them in

a cool, dry place and away from direct exposure to the sun's rays.



Winter or 4-seasons tyres can be identified by this symbol on their sidewalls.

TYRE SAFETY INFORMATION

Drive over edges slowly and at right angles if possible. Driving over sharp edges can cause tyre and wheel damage. Do not trap tyres on the kerb when parking.

Regularly check the wheels for damage. Seek the assistance of a workshop in the event of damage or unusual wear.

TYRE PRESSURE

Check the pressure of cold tyres at least every 14 days and before any long journey.

Do not forget the spare wheel.

⇨ page 215

This also applies to vehicles with tyre deflation detection system.

⇨ page 171

The tyre pressure information label on the left or right door frame indicates

the original equipment tyres and the corresponding tyre pressures.

The tyre pressure data refers to cold tyres. It applies to summer and winter tyres.

Always inflate the spare tyre to the pressure specified for full load.

Incorrect tyre pressures will impair safety, vehicle handling, comfort and fuel economy and will increase tyre wear.

Tyre pressures differ depending on various options. For the correct tyre pressure value, follow the procedure below:

1. Identify the respective tyre.
2. Identify the engine identifier code.

⇒ page 205

The tyre pressure tables show all possible tyre combinations.

⇒ page 215

For the tyres approved for your vehicle, refer to the Certificate of Conformity provided with your vehicle or other national registration documents.

The driver is responsible for correct adjustment of tyre pressure.

⚠ Warning

If the pressure is too low, this can result in considerable tyre warm-up and internal damage, leading to tread separation and even to tyre blow-out at high speeds.

⚠ Warning

For specific tyres the recommended tyre pressure as shown in the tyre pressure table may exceed the maximum tyre pressure as indicated on the tyre.

Never exceed the maximum tyre pressure as indicated on the tyre.

Temperature dependency

The tyre pressure depends on the temperature of the tyre. During driving, tyre temperature and pressure increase. Tyre pressure values provided on the tyre information label and tyre pressure chart are valid for cold tyres, which means at 20 °C.

The pressure increases by nearly 10 kPa for a 10 °C temperature increase. This must be considered when warm tyres are checked.

TREAD DEPTH

Check tread depth at regular intervals.

For safety reasons, it is recommended that the tread depth of the tyres on one axle should not vary by more than 2 mm.



The legally permissible minimum tread depth (1.6 mm) has been reached when the tread has worn down as far as one of the tread wear indicators (TWI). Their position is indicated by markings on the sidewall.

If there is more wear at the front than the rear, swap round front wheels and rear wheels periodically. If directional tyres are mounted, ensure that the direction of rotation of the wheels remains the same.

Tyres age, even if they are not used.

We recommend tyre replacement every 6 years.

WINTER TYRES

Winter tyres improve driving safety at temperatures below 7 °C and should therefore be fitted on all wheels.

In accordance with country-specific regulations, affix the speed sticker in the driver's field of view, if the tyre speed code is below the maximum speed of the vehicle.

All tyre sizes are permitted as winter tyres ⇒ page 215

WHEEL COVERS

Wheel covers and tyres that are factory approved for the respective vehicle and comply with all of the relevant wheel and tyre combination requirements must be used.

If the wheel covers and tyres used are not factory approved, the tyres must not have a rim protection ridge.

Wheel covers must not impair brake cooling.

Warning

Use of unsuitable tyres or wheel covers could lead to sudden pressure loss and thereby accidents.

Vehicles with steel wheel rims: When using locking wheel nuts, do not attach wheel covers.

Temporary spare wheel: Do not use wheel covers

Bodywork - exterior care

Locks

The locks are lubricated at the factory using a high quality lock cylinder grease. Use a de-icing agent only when absolutely necessary, as this has a degreasing effect and impairs lock function. After using a de-icing agent, have the locks regreased by a workshop.

Washing

The paintwork is exposed to environmental influences.

Bird droppings, dead insects, resin, pollen and the like should be cleaned off immediately, as they contain aggressive constituents which can cause paint damage.

If using a vehicle wash, comply with the vehicle wash manufacturer's instructions. The windscreen wiper and rear window wiper must be switched off. Remove aerial and external accessories such as roof racks etc.

If the vehicle is washed by hand, make sure that the insides of the wheel housings are also thoroughly rinsed out.

Clean edges and folds on opened doors and the bonnet as well as the areas they cover.

Clean bright metal mouldings with a cleaning solution approved for aluminium to avoid damage.

CAUTION

Always use a cleaning agent with a pH value of four to nine. Do not use cleaning agents on hot surfaces.

Do not clean the engine compartment with a steam-jet or high-pressure jet cleaner.

Thoroughly rinse and leather-off the vehicle. Rinse leather frequently. Use separate leathers for painted and glass surfaces: remnants of wax on the windows will impair vision.

Have the door hinges of all doors greased by a workshop.

Do not use hard objects to remove spots of tar. Use tar removal spray on painted surfaces.

Exterior lights

Headlight and other light covers are made of plastic. Do not use any abrasive or caustic agents, do not use an ice scraper and do not clean them dry.

Polishing and waxing

Polishing is necessary only if the paint has become dull or if solid deposits have become attached to it.

Plastic body parts must not be treated with wax or polishing agents.

Windows and windscreen wiper blades

Switch off wipers before handling in their areas.

Use a soft lint-free cloth or chamois leather together with window cleaner and insect remover.

When cleaning the rear window from inside, always wipe in parallel to the heating element to prevent damage.

For mechanical removal of ice, use a sharp-edged ice scraper. Press the scraper firmly against the glass so that no dirt can get under it and scratch the glass.

Clean smearing wiper blades with a soft cloth and window cleaner. Also make sure to remove any residues such as wax, insect residues and similar from the window.

Ice residues, pollution and continuous wiping on dry windows will damage or even destroy the wiper blades.

Wheels and tyres

Do not use high-pressure jet cleaners.

Clean rims with a pH-neutral wheel cleaner.

Rims are painted and can be treated with the same agents as the body.

Paintwork damage

Rectify minor paintwork damage with a touch-up pen before rust forms.

Have more extensive damage or rust areas repaired by a workshop.

Underbody

Some areas of the vehicle underbody have a PVC undercoating, whereas other critical areas have a durable protective wax coating.

After the underbody is washed, check the underbody and have it waxed if necessary.

Bitumen / rubber materials could damage the PVC coating. Have underbody work carried out by a workshop.

Before and after winter, wash the underbody and have the protective wax coating checked.

Towing equipment

Do not clean the coupling ball bar with a steam-jet or high-pressure jet cleaner.

Interior care

Interior and upholstery

Only clean the vehicle interior, including the instrument panel fascia and panelling, with a dry cloth or interior cleaner.

The instrument cluster and the displays should only be cleaned using a soft damp

cloth. If necessary use a weak soap solution.

Clean fabric upholstery with a vacuum cleaner and brush. Remove stains with an upholstery cleaner.

Clothing fabrics may not be colour-fast. This could cause visible discolourations, especially on light-coloured upholstery. Removable stains and discolourations should be cleaned as soon as possible.

Clean seat belts with lukewarm water or interior cleaner.

CAUTION

Close Velcro fasteners as open Velcro fasteners on clothing could damage seat upholstery.

The same applies to clothing with sharp-edged objects, like zips or belts or studded jeans.

PLASTIC AND COATED PARTS

Plastic and rubber parts can be cleaned with the same cleaner as used to clean the body. Use interior cleaner if necessary. Do not use any other agent. Avoid solvents and petrol in particular. Do not use high-pressure jet cleaners.

FLOOR MATS

Warning

If a floor mat has the wrong size or is not properly installed, it can interfere with pedals, potentially causing unintended acceleration or increased stopping distance that may result in collision and injury.

Use the following guidelines for proper floor mat usage.

- The original equipment floor mats were designed for this vehicle. If the floor mats need to be replaced, it is recommended to buy certified floor mats that fit properly and are fixed by the retainers on the driver side. Always check that the floor mats do not interfere with the pedals.
- Use the floor mat with the correct side up. Do not turn it over.
- Do not place anything on top of the driver's side floor mat.
- Use only a single floor mat on the driver's side.

Installing and removing the floor mats

The driver's side floor mat is held in place by two retainers.

To install the floor mat:

1. Move the seat backwards as far as possible.

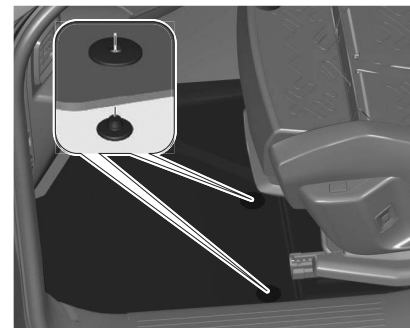

2. Align slots in the mat with the retainers, as shown.
3. Push the mat to the floor.

To remove the floor mat:

1. Move the seat backwards as far as possible.
2. Pull the floor mat upwards to remove.

 **Warning**

To avoid any risk of jamming the pedals:

- Only use mats that are suited to the fixings already present in the vehicle; these fixings must be used.
- Never fit one mat on top of another.

The use of mats not approved by the Manufacturer may interfere with access to the pedals and hinder the operation of the cruise control/speed limiter.

The approved mats have two fasteners located underneath the seat.

Technical specifications

Vehicle identification.....	202
Vehicle Identification Number (VIN)	
.....	202
Identification plate.....	202
Engine identification.....	203
Vehicle data.....	203
Dimensions.....	204
Engine data.....	205
High voltage battery.....	207
Towing weights.....	210
Capacities.....	213
Wheels and tyres.....	213
Tyre markings / designations.....	213
Tightening torques.....	213
Tyre pressures.....	215
Tyre chains.....	216

Vehicle identification

VEHICLE IDENTIFICATION NUMBER (VIN)

The vehicle identification number may be embossed on the instrument panel, visible through the windscreen, or in the engine compartment on the right body panel.

IDENTIFICATION PLATE

The identification plate is located on the front left or right door frame. The layout and position differ for some export countries.

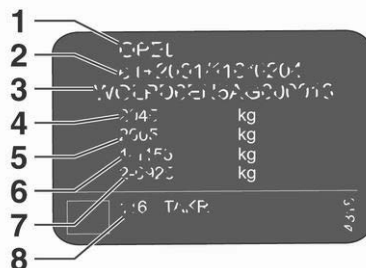

Information on identification label:

- 1** : manufacturer
- 2** : type approval number
- 3** : vehicle identification number
- 4** : permissible gross vehicle weight rating in kg
- 5** : permissible gross train weight in kg
- 6** : maximum permissible front axle load in kg
- 7** : maximum permissible rear axle load in kg
- 8** : manufacturer address, vehicle-specific or country-specific data

The combined total of front and rear axle loads must not exceed the permissible gross vehicle weight.

Vehicle's kerb weight depends on the specification of the vehicle, e.g. optional equipment and accessories.

Refer to the Certificate of Conformity provided with your vehicle or other national registration documents.

The technical data is determined in accordance with European Community standards. We reserve the right to make modifications.

Specifications in the vehicle documents always have priority over those given in this manual.

ENGINE IDENTIFICATION

The technical data tables use the engine identifier code. The engine data table additionally shows the engineering code.

Engine data ⇒ page 205.

To identify the respective engine, refer to the EEC Certificate of Conformity provided with this vehicle or other national registration documents.

Vehicle data

Engines

The engine characteristics are given in the vehicle's registration document, as well as in sales brochures.

Only the values available at the time of publication are presented in the tables.

Contact a dealer or a qualified workshop to obtain missing values.

Tip

The maximum power corresponds to the value type-approved on a test bed, as defined by Regulation EU 715/2007.

For more information, contact a dealer or a qualified workshop.

Weights and towed loads

The weights and towed loads relating to the vehicle are indicated on the registration document, as well as in sales brochures.

These values are also indicated on the manufacturer's plate or label.

For more information, contact a dealer or a qualified workshop.

The GTW (Gross Train Weight) and towed load values indicated are valid up to a maximum altitude of 1,000 metres. The towed load value must be reduced by 10% for each additional 1,000 metres of altitude.

The maximum authorised nose weight corresponds to the weight permitted on the towball.

Warning

Towing even with a lightly loaded vehicle can adversely affect its road holding.

Braking distances are increased when towing a trailer.

When using a vehicle to tow, never exceed a speed of 62 mph (100 km/h) (observe the local legislation in force).

Warning

When exterior temperatures are high, the vehicle performance may be limited in order to protect the engine. When the exterior temperature is higher than 37°C, reduce the towed weight.

DIMENSIONS

Size	MHEV	PHEV	BEV
Length [mm]	4650.1	4650.1	4650.1
Width [mm]	1904.8	1904.8	1904.8
Width with two exterior mirrors folded [mm]	1934	1934	1934
Width with two exterior mirrors [mm]	2108.3	2108.3	2108.3
Height (curb weight) [mm]	1665.2	1667.2	1666.4
Height on BIW (curb weight) [mm]	1648.2	1649.2	1648.7
Loading height	765.3	768.9	769.4
Height (with boot lid open)	2093.3	2096.7	2098.2
Turning diameter between pavements [m]	10.90	10.93	10.93
Turning diameter between walls [m]	11.44	11.44	11.44
Wheelbase [mm]	2784.1	2784.1	2794.6
Fuel tank capacity [l] / Battery capacity [Ah]	55l	55l - 17 Ah (net) (21 Ah gross)	75 Ah (net) (85 Ah gross)

ENGINE DATA

Hybrid 48V

Engine identifier code	EB2LTDH2 EDCT6	EP6LTCHPD EDCT7
Gearbox	Electric dual-clutch automatic 6-speed	Electric dual-clutch automatic 7-speed
Cubic capacity (cc)	1,199	1598
Fuel type	Unleaded	Unleaded
Authorised octane indexes	95 (recommended), 98, 91	95 (recommended), 98, 91
Electric engine	Synchronous with permanent magnets	Synchronous with permanent magnets
Max. power (kW)	21	92
Combined power (kW)	//	143

Electric engines

Version	EV 210 Standard Range	EV 320 Standard Range	EV 230 High Range
Code	ELEC ZLC RGML 210 hp ZKZ	ELEC ZLX RGML_eRAD 320 hp AWD ZE	ELEC ZLC RGML 230 hp
Electric engine	Synchronous with permanent magnets	Synchronous with permanent magnets	Synchronous with permanent magnets
Max. power (kW/hp)	154/213	235/320	169/230

HIGH VOLTAGE BATTERY

Technology	Lithium-ion
Voltage (Volts DC)	48
Useful capacity (kWh)	0.4

208 Technical specifications

Plug-in hybrid vehicles

Technology	Lithium-ion
Voltage (Volts DC)	240-400
Useful capacity (kWh)	17.9

Electric engines

Technology	Lithium-ion
Voltage (Volts DC)	400
Useful capacity (kWh)	73 (FDB)/ 74 (ACC 11) ; 82.2 (ACC 12)/ 96.9 (ACC HR)
Domestic charging	Mode 2
Alternating current (AC) voltage rating (A)	230 (single-phase) 8 or 16
Accelerated charging	Mode 3
Alternating current (AC) voltage rating (A)	230 (single-phase or three-phase) 16 or 32
Superfast charging	Mode 4
Direct current (DC) voltage	400

TOWING WEIGHTS

Hybrid 48V engines

Braked trailer (within the GTW limit) on a 10% or 12% gradient (kg)	850 ⁽¹⁾ / 1,100 ⁽²⁾
---	---

Unbraked trailer (kg)	600
-----------------------	-----

Maximum authorised nose weight (kg)	80
-------------------------------------	----

(1) : non-factory fitted hook

(2) : factory fitted hook

Plug-in hybrid engines

Braked trailer (within the GTW limit) on a 10% or 12% gradient (kg)	1,500
Unbraked trailer (kg)	600
Maximum authorised nose weight (kg)	80

212 Technical specifications

Electric engines

Braked trailer (within the GTW limit) on a 10% or 12% gradient (kg)	1,200
---	-------

Unbraked trailer (kg)	600
-----------------------	-----

Maximum authorised nose weight (kg)	80
-------------------------------------	----

Capacities

Fuel tank : 55 L

Wheels and tyres

TYRE MARKINGS / DESIGNATIONS

E.g. **215/60 R17 96H**

215 : tyre width, mm

60 : cross-section ratio (tyre height to tyre width), %

R : belt type: Radial

RF : type: RunFlat

15 : wheel diameter, inches

91 : load index e.g. 95 is equivalent to 615 kg

T : speed code letter

Speed code letter:

Q : up to 100 mph

S : up to 112 mph

T : up to 118 mph

H : up to 130 mph

V : up to 150 mph

W : up to 168 mph

Choose a tyre appropriate for the maximum speed of the vehicle.

The maximum speed is achievable at kerb weight with driver (75 kg) plus 125 kg payload. Optional equipment could reduce the maximum speed of the vehicle.

Directional tyres

Directional tyres should be mounted so that they rotate in the correct direction. The proper rotation direction is indicated by a symbol (e.g. an arrow) on the sidewall.

TIGHTENING TORQUES

Warning

Ensure to use always the correct wheel bolts if changing the wheels. When installing the spare wheel for temporary usage, the bolts for alloy wheel rims can also be used.

Depending on the wheel rim material, two different bolts are available.



Tightening torque for alloy wheel rims is 115 Nm.



Tightening torque for steel wheel rims is 125 Nm.

Use the correct wheel bolts for the respective wheel rims.

Jacking positions

The jacking positions shown refer to the use of lifting arms and accessory jacks used for changing winter / summer tyres.

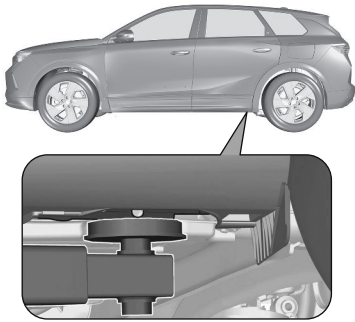

The front arm of the lifting platform is positioned centrally under the relevant vehicle jacking point.

The rear arm of the lifting platform is positioned centrally under the relevant vehicle jacking point. On BEV vehicles, there is a protective cover that must be removed first.

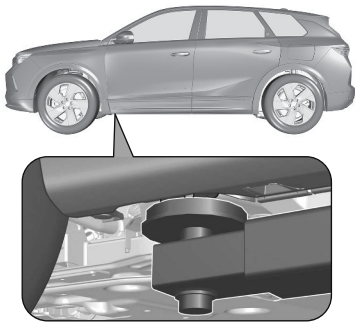

TYRE PRESSURES

Tyres	Vehicle up to 3 people		With full load		Spare wheel	Space-saving spare wheel
	Front [kPa/bar] ([psi])	Rear [kPa/bar] ([psi])	Front [kPa/bar] ([psi])	Rear [kPa/bar] ([psi])		
225/55 R19 103V	230/2.3 (29)	230/2.3 (29)	241/2.4 (35)	280/2.8 (40)	300/3 (43.5)	413/4.2 (61)
235/55 R19 105V	250/2.5 (36) ⁽¹⁾	220/2.2 (32) ⁽¹⁾	270/2.7 (39)	290/2.9 (42) ⁽¹⁾	N/A	413/4.2 (61)
	260/2.6 (38) ⁽²⁾	260/2.6 (38) ⁽²⁾		320/3.2 (46) ⁽²⁾		
235/50 R20 104V	260/2.6 (38) ⁽¹⁾	230/2.3 (29)	280/2.8 (40)	290/2.9 (42) ⁽¹⁾	N/A	413/4.2 (61)
		270/2.7 (39) ⁽²⁾⁽³⁾		320/3.2 (46) ⁽²⁾⁽³⁾		
	290/2.9 (42) ⁽³⁾					
225/55 R19 103V XL 3PMSF	200/2.3 (29)	200/2.3 (29)	240/2.4 (35)	280/2.8 (40)	N/A	413/4.2 (61)
235/55 R19 105V 3PMSF	230/2.3 (29)	230/2.3 (29)	240/2.4 (35)	280/2.8 (40)	N/A	413/4.2 (61)
225/55 R19 103V M+S	250/2.5 (36) ⁽¹⁾	220/2.2 (32) ⁽¹⁾	270/2.7 (39)	290/2.9 (42) ⁽¹⁾	N/A	413/4.2 (61)
	260/2.6 (38) ⁽²⁾	260/2.6 (38) ⁽²⁾		320/3.2 (46) ⁽²⁾		
235/50 R20 104V XL	240/2.4 (35)	220/2.2 (32)	240/2.4 (35)	280/2.8 (40)	N/A	413/4.2 (61)

1: PHEV FWD

2: BEV FWD

3: BEV AWD

TYRE CHAINS

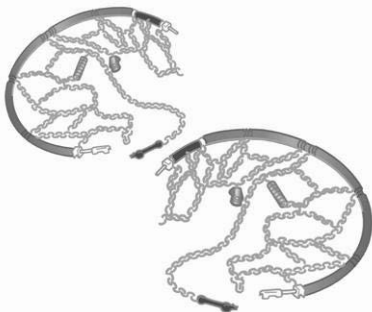

Tyre chains are only permitted on the front wheels.

Only use tyre chains designed to be used with tyre type of the vehicle:

- For 18 inch and 19 inch tyres, only use fine mesh tyre chains that add no more than 9 mm to the tyre tread and the inboard sides (including chain lock).
- For 20 inch tyres, only use Polaire PSGB 140 tyre chains.

Note

The use of tyre chains and the maximum allowed speed is regulated by country-specific legislation.

When fitting the tyre chains follow the instructions provided by the manufacturer of the tyre chains.

After having fitted the tyre chains, stop the vehicle after having driven a short distance and make sure that the tyre chains are correctly tightened.

⚠ Warning

Damage may lead to tyre blowout.

Temporary spare wheel

The use of tyre chains is not permitted on the temporary spare wheel.

Customer information

Declaration of conformity.....	217
REACH.....	218
Software update.....	218
Registered trademarks.....	219
Vehicle data recording and privacy	219

Declaration of conformity

Transmission systems

This vehicle has systems that transmit and / or receive radio waves subject to Directive 2014/53/EU and The Radio Equipment Regulations 2017 by the United Kingdom. The manufacturers of the systems listed below declare conformity with Directive 2014/53/EU and The Radio Equipment Regulations 2017. The full text of the EU declaration of conformity for each system is available at the following internet address:
www.vauxhall.co.uk/conformity

Importer is Vauxhall Motors Limited, MP UK 1-101-135, Chalton House, Luton Road, Chalton, Luton, Bedfordshire, LU4 9TT, United Kingdom.

BTA module

Magneti Marelli S.p.A.

Viale A. Borletti 61/63, 20011 Corbetta, Italy

Operation frequency (MHz)	Maximum output (dBm)
880 -915	33
1710 - 1785	24

1850 -1910 24

1920 - 1980 24

2500 - 2570 23

Antenna module

Laird

Daimlerring 31, 31135 Hildesheim, Germany
Operation frequency: N/A

Maximum output: N/A

Radio remote control transmitter

Hülsbeck & Fürst GmbH & Co. KG
Steeger Str. 17, 42551 Velbert, Germany

Operation frequency: 433.92 MHz

Maximum output: 10 dBm

Radio remote control receiver

Delphi European, Middle Eastern & African Regional Offices Customer Technology

Center Avenue de Luxembourg, L-4940
Bascharage, G.D. of Luxembourg

Operation frequency: 119.0 - 128.6 kHz

Maximum output: 16dB μ A/m @ 10m

Electronic key transmitter

Valeo

43 Rue Bayen, 75017 Paris, France
Operation frequency: 433.92 MHz

Maximum output: 10 dBm

immobiliser

KOSTAL of America, Inc.

350 Stephenson Hwy, Troy MI 48083,
USA

Operation frequency: 125 kHz

Maximum output: 5 dB μ A/m at 10m

ICASA type approval numbers

List of all Independent Communications Authority of South Africa (ICASA) type approval numbers:

TA-2016/121, TA-2016/3261,

TA-2017/2387, TA-2017/2745,

TA-2013/430, TA-2017/1106,

TA-2016/929, TA-2017/3180

REACH

Registration, Evaluation, Authorisation and Restriction of Chemicals (REACH) is a European Union regulation adopted to improve the protection of human health and the environment from the risks that can be posed by chemicals. Visit www.vauxhall.com/reach for further

information and for access to the Article 33 communication.

SOFTWARE UPDATE

The Infotainment system can download and install selected software updates over a wireless connection.

Note

The availability of these over-the-air vehicle software updates varies by vehicle and country. Find more information on our website.

Remote device management and remote software and firmware updates

As an integral part of the service related to the performance of subscribed connected service contracts, necessary device management and necessary software and firmware updates related to the software and firmware for the named connected service will be performed remotely, in particular by using over-the-air technology.

For this, a secure radio network connection between the vehicle and the device management server will be established when ignition is switched on and a mobile network is available.

Depending on the equipment of the vehicle, connection configuration must be set to **Connected vehicle** to allow the establishment of the radio network connection.

Irrespective of a valid connected service subscription, remote product security or product safety related device management and software and firmware updates will be performed when the processing is necessary for the compliance with a legal obligation to which the manufacturer is subject (e.g. applicable product liability law, emergency call regulation) or when the processing is necessary in order to protect the vital interests of the respective vehicle users and passengers.

The establishment of a secure radio network connection and the related remote updates are not affected by privacy settings and will be performed in principal after an initiation by the vehicle user following a respective notification.

The system is able to notify receipt of an update as soon as it is connected to an exterior Wi-Fi network or a mobile network. Large updates are downloaded only via the Wi-Fi network.

The availability of an update is notified on the Info Display at the end of a trip

with an option of immediate installation or postponement of installation.

The installation time is variable and can take several minutes, or up to a maximum time of about 30 minutes. A notification will give an estimate of the duration and a description of the update.

Updates can be checked manually via the Info Display. Follow the on-screen prompts in the respective menu.

Note

Steps for downloading and installing updates may vary by vehicle.

For safety reasons and because it requires sustained attention by the driver, the installation must be carried out with the ignition on without starting the engine. The installation cannot be carried out in the following cases:

- engine running
- emergency call in progress
- insufficient vehicle battery charge
- charging the vehicle's high-voltage battery

Note

During the installation process, the vehicle may not be operational.

If the update has failed, seek the assistance of a workshop.

REGISTERED TRADEMARKS

Apple Inc.

Apple CarPlay™ is a trademark of Apple Inc.

App Store® and iTunes Store® are registered trademarks of Apple Inc.

iPhone®, iPod®, iPod touch®, iPod nano®, iPad® and Siri® are registered trademarks of Apple Inc.

Bluetooth SIG, Inc.

Bluetooth® is a registered trademark of Bluetooth SIG, Inc.

DivX, LLC DivX® and DivX Certified® are registered trademarks of DivX, LLC.

Google Inc.

Android™ and Google Play™ Store are trademarks of Google Inc.

Velcro Companies

Velcro® is a registered trademark of Velcro Companies.

VEHICLE DATA RECORDING AND PRIVACY

Emergency call data recording and privacy

Data processing

All processing of personal information by the emergency call function complies with the framework for protection of personal information established by Regulation 2016/679 (GDPR) and Directive 2002/58/EC of the European Parliament and the Council, and in particular, seeks to protect the vital interests of the data subject, in accordance with article 6.1, paragraph d) of Regulation 2016/679.

The processing of personal information is strictly limited to the requirements of the emergency call function used with the European emergency call number.

The emergency call function is only able to collect and process the following data relating to the vehicle: chassis number, type (passenger vehicle or light commercial vehicle), fuel type or power source, three most recent locations and direction of travel, number of passengers and a timestamped log file recording technical data related to the system's operation.

The recipients of the processed data are the emergency call handling centres designated by the relevant national authorities in the territory in which they are located, enabling priority routing and handling of calls to the emergency number.

Data storage

Data contained in the system's memory is not accessible from outside the system until a call is made. The system is not traceable and is not continuously monitored in its normal operation mode.

The data in the system's internal memory is automatically and continuously erased. Only the vehicle's three most recent locations, necessary for the normal functioning of the system, are stored.

When an emergency call is triggered, the data log is stored for no more than 13 hours.

Access to data

You have the right to access the data and, if necessary, submit a request to rectify, erase or restrict the processing of any personal information not processed in accordance with the provisions of Regulation 2016/679 (GDPR). Third parties to which data has

been communicated shall be notified of any rectification, erasure or restriction carried out in accordance with the aforementioned directive, unless doing so would be impossible or require a disproportionate effort.

You also have the right to lodge a complaint with the relevant data protection authority.

If you want to claim your above-mentioned rights please contact us per email at privacyrights@mpsa.com.

For more information regarding our contact details, please take a look at our Privacy & Cookies Policy on our website.

EVENT DATA RECORDERS

Electronic control units are installed in your vehicle. Control units process data that is received by vehicle sensors, for example, or which they generate themselves or exchange amongst themselves. Some control units are necessary for the safe functioning of your vehicle, others assist you while you drive (driver assistance systems), while others provide comfort or infotainment functions.

The following contains general information about data processing in the vehicle. You will find additional information as to which specific data

is uploaded, stored and passed on to third parties and for what purpose in your vehicle under the keywords Data Protection closely linked to the references for the affected functional characteristics in the relevant owner's manual or in the general terms of sale. These are also available online.

Operating data in the vehicle

Control units process data for operation of the vehicle.

This data includes, for example:

- vehicle status information (e.g. speed, movement delay, lateral acceleration, wheel rotation rate, "seat belts fastened" display)
- ambient conditions (e.g. temperature, rain sensor, distance sensor)

As a rule, such data is transient and is not stored for longer than an operational cycle, and only processed on board the vehicle itself. Often control units include data storage (including the vehicle key). This is used to allow information to be documented temporarily or permanently on vehicle condition, component stress, maintenance requirements and technical events and errors.

Depending on technical equipment levels, the data stored is as follows:

- system component operating states (e.g. fill level, tyre pressure, battery status)
- faults and defects in important system components (e.g. lights, brakes)
- system reactions in special driving situations (e.g. triggering of an airbag, actuation of the stability control systems)
- information on events damaging the vehicle
- for electric vehicles the amount of charge in the high-voltage battery, estimated range

In special cases (e.g. if the vehicle has detected a malfunction), it may be necessary to save data that would otherwise just be volatile.

When you use services (e.g. repairs, maintenance), the operating data saved can be read together with the vehicle identification number and used where necessary. Staff working for the service network (e.g. garages, manufacturers) or third parties (e.g. breakdown services) can read the data from the vehicle. The same applies to warranty work and quality assurance measures.

Data is generally read via the OBD (On-Board Diagnostics) port prescribed by law in the vehicle. The operating data read documents the technical condition of the vehicle or individual components and assists with fault diagnosis, compliance with warranty obligations and quality improvement. This data, in particular information on component stress, technical events, operator errors and other faults, is transmitted to the manufacturer where appropriate, together with the vehicle identification number. The manufacturer is also subject to product liability. The manufacturer potentially also uses operating data from vehicles for product recalls. This data can also be used to check customer warranty and guarantee claims.

Fault memories in the vehicle can be reset by a service company when carrying out servicing or repairs or at your request.

Comfort and infotainment functions

Comfort settings and custom settings can be stored in the vehicle and changed or reset at any time.

Depending on the equipment level in question, these include

- seat and steering wheel position settings
- chassis and air conditioning settings
- custom settings such as interior lighting

You can input your own data in the infotainment functions for your vehicle as part of the selected features.

Depending on the equipment level in question, these include

- multimedia data such as music, videos or photos for playback in an integrated multimedia system
- address book data for use with an integrated hands-free system or an integrated navigation system
- input destinations
- data on the use of online services

This data for comfort and infotainment functions can be stored locally in the vehicle or be kept on a device that you have connected to the vehicle (e.g. a smartphone, USB stick or MP3 player). Data that you have input yourself can be deleted at any time.

This data can only be transmitted out of the vehicle at your request, particularly when using online services in

accordance with the settings selected by you.

Smartphone integration, e.g. Android Auto or Apple CarPlay

If your vehicle is equipped accordingly, you can connect your smartphone or another mobile device to the vehicle so that you can control it via the controls integrated in the vehicle. The smartphone image and sound can be output via the multimedia system in this case. At the same time, specific information is transmitted to your smartphone.

Depending on the type of integration, this includes data such as position data, day / night mode and other general vehicle information. For more information, please see the operating instructions for the vehicle / infotainment system.

Integration allows selected smartphone apps to be used, such as navigation or music playback. No further integration is possible between smartphone and vehicle, in particular active access to vehicle data. The nature of further data processing is determined by the provider of the app used. Whether you can define settings, and if so which ones, is dependent on the app in question and your smartphone's operating system.

Online services

If your vehicle has a radio network connection, this allows data to be exchanged between your vehicle and other systems. The radio network connection is made possible by means of a transmitter device in your vehicle or a mobile device provided by you (e.g. a smartphone). Online functions can be used via this radio network connection. These include online services and applications / apps provided to you by the manufacturer or other providers.

Proprietary services

In the case of the manufacturer's online services, the relevant functions are described by the manufacturer in an appropriate location (e.g. Owner's Manual, the manufacturer's website) and the associated data protection information is provided. Personal data may be used to provide online services. Data exchange for this purpose takes place via a protected connection, e.g. using the manufacturer's IT systems provided for the purpose. Collection, processing and use of personal data for the purposes of preparation of services take place solely on the basis of legal permission, e.g. in the case of a legally prescribed emergency communication

system or a contractual agreement, or by virtue of consent.

You can activate or deactivate the services and functions (which are subject to charges to some extent) and, in some cases, the vehicle's entire radio network connection. This does not include statutory functions and services such as an emergency communication system.

Onboard fuel consumption meter (OBFCM)

This function will be provided for the entire life cycle of the vehicle.

In accordance with Article 9 of Implementing Regulation (EU) 2021/392 ("OBFCM"), this regulatory service allows the European Environment Agency (EEA) to collect vehicle data related to usage (such as VIN, total distance travelled, total fuel consumed, total grid energy into battery when applicable).

This data is used by EEA to monitor in real usage the fuel and energy consumption and the CO2 emission of the new vehicles in an anonymised and aggregated way.

The collection and transmission of vehicle's data for regulatory OBFCM purpose can be refused. This can be

done by contacting Customer Care Centre (contact details available online).

Third-party services

If you make use of online services from other providers (third parties), these services are subject to the liability and data protection and usage conditions of the provider in question.

The manufacturer frequently has no influence over the content exchanged in this regard.

Therefore, please note the nature, scope and purpose of the collection and use of personal data within the scope of third-party services provided by the service provider in question.

In case of an accident

This vehicle is fitted with an event data recorder. This system gathers and records certain vehicle data over a short period (a few seconds) before, during and after an event such as an accident or collision. In order to gain a better understanding of the circumstances surrounding the event, the system records how the vehicle's various systems are operating at the time of the event, including:

- any deployment of a restraint system (airbag, seat belt, etc.)

- the status of all seat belts (fastened / unfastened)
- the contact or intensity of pressure exerted on the pedal(s) engaged by the driver
- the speed of the vehicle
- the status of some driving and driver assistance systems.

The following are not recorded:

- data on normal driving conditions, in other words data not directly related to the event
- personal data on the driver and any other occupants
- the geographical location of the vehicle at the time of the event.

The reading of data recorded by the event data recorder requires both:

- access to the interior of the vehicle or to the event data recorder
- special equipment that can be purchased from the manufacturer Bosch.

Aside from the vehicle manufacturer, other parties such as law enforcement agencies may access this data in order to analyse the event.

RADIO FREQUENCY IDENTIFICATION (RFID)

RFID technology is used in some vehicles for functions such as tyre pressure monitoring and immobiliser. It is also used in connection with conveniences such as radio remote controls for door locking / unlocking and starting. RFID technology in Vauxhall vehicles does not use or record personal information or link with any other Vauxhall system containing personal information.

CONTENTS

A	
ABS	111
Accessories	187
Accessory, 12 V	66
Active emergency braking ...	81, 113, 137
ADAS	137
Adjusting seat	18
Adjusting the lumbar support	21
Adjusting the seat angle	21
Adjusting the time	104
Advanced driving assistance system .	137
Airbag	26, 27
Airbag, child restraint	27
Airbag, curtain	30
Airbag, deactivation	30
Airbag, front	29
Airbag, side	30
Anti-theft system	10
Applications	90
Audio streaming (Bluetooth)	101
Automatic light control	44
B	
Blanking screen (snow shield)	188
Blind	50
Bluetooth (hands-free)	95
Bluetooth (telephone)	95
Brake assist	113
Brake fluid	192, 195
Brakes	111, 192
C	
Child lock	10
Child restraint	32
Child seats, ISOFIX	32
cluster	68
Cluster	68
Comfort entry function	18
Connection, Bluetooth	95
Connectivity	95
Coolant, antifreeze	195
D	
Date (setting)	104
Display, head-up	18
Drive modes	118
Driving positions (storing)	
Storing driving positions	18
E	
Engine coolant	191
Engine oil	190, 195
Engines	203
Exterior care	198
Exterior lighting	44
F	
First aid kit	54
Fitting roof bars	55
Fog lights, rear	46
Folding the backrest	24
Forward collision warning	142
Frequency (radio)	99
Fuel consumption	122
G	
Glove box	52

H			
Head restraints, front	17		
Head restraints, rear	17		
Headlight, adjustment	45		
Headlight, flash	45		
Headlight, high beam	44		
Headlight, light switch	44		
Heated and ventilated seats	22		
I			
Inflating tyres	196		
Interior care	199		
ISOFIX mountings	37		
J			
Jack	213		
Jump starting	183		
K			
Key, replacing battery	8		
Kit, hands-free	95		
L			
Lane keeping assist	148		
Lane positioning assist	152		
Lashing eyes	53		
Lighting, exterior	44		
Lights, parking	49		
Load reduction mode	56		
Loading	55		
Locking, automatic	7		
Locks	198		
Lumbar	21		
M			
Manual seat adjustment	19		
Manual transmission	78		
Massage function	23		
Massage multi-point	23		
Mats	200		
Mirrors	16, 17		
Mirrors, exterior	16		
Mirrors, folding	16		
Mirrors, interior	17		
P			
Park assist	155		
Parking assist	155		
Parking brake	112		
Pedals	107		
Personalisation	88		
Power saving mode	194		
Pressures, tyres	196		
Profiles	85		
Propulsion type	3		
R			
Radio	99		
Rear camera	157		
Rear cross traffic alert	162		
Rear seats	24		
Recommended fluids	194		
Recommended lubricants	194		
Refuelling	121		
Roof bars	55		
S			
Screens, very cold conditions	188		
Seat belt reminder	25		
Seat belts, three-point	26		
Seat position	19		
Seats, electric	21		
Seats, heated	22		
Semi-automatic lane changing	150		
Service display	71		
Shield, snow	188		
Side blind spot alert	145		
Snow screen	188		
Spare wheel	178		
Speed limiter	165		
Start - stop	109		
Station, radio	99		
Stay, engine bonnet	61		
Steering wheel, controls	40		
Sunroof, panoramic	50		
T			
Tail lights	44		
Technical data	203		
Telephone	95, 102		
Time (setting)	104		
Tools	178		
Towed loads	203		
Towing	132–134		
Towing another vehicle	186		
Towing eye	186		
Towing the vehicle	185		
Tread depth	197		
Turn lights	46		
Tyre chains	216		
Tyre designations	213		
Tyre pressure	196		

Tyre pressure monitoring system	171
Tyre repair kit	181
Tyres	196, 198

U

Updating the time	104
USB sockets	66

V

Vehicle battery	192
Vehicle battery, replacing	193
Vehicle messages	73

W

Warning and indicators light	74
Warning triangle	54, 177
Washer	42
Washer fluid	195
Washing	198
Weights	203
Wheel covers	198
Windows	14
Windows, child lock	15
Winter tyres	198
Wiper	42

Copyright by Vauxhall Motors Ltd.

The information contained in this publication is effective as of the date indicated below. Vauxhall Motors Ltd. reserves the right to make changes to the technical specifications, features and design of the vehicles relative to the information contained in this publication, as well as changes to the publication itself.

Edition: July 2024, Vauxhall Motors Ltd.

Printed on chlorine-free bleached paper.

VGRANBO2407en

